

# AF

## G1/8 ÷ G1 1/2 Poppet valves for compressed air

- Wide range: G1/8 - G1/4 - G3/8 - G1/2 - G3/4 - G1 - G1 1/2
- Original Univer poppet system appreciated for decades
- Suitable for applications where high flow rate and high cycles rates are required
- G1 - 2/2 version for blowing



### TECHNICAL CHARACTERISTICS

Ambient temperature	+50 °C max						
Fluid temperature	-5 ÷ +60 °C						
Fluid	filtered air 50 µm, lubricated or not						
Commutation system	poppet						
Ways/Positions	<b>2/2 NC (upon request), 3/2 NC, 3/2 NO, 3/2 NC-NO</b>						
Pressure	max 10 bar						
Control	pneumatic, indirect electropneumatic						
Return	pneumomechanical spring						
Connections	G1/8	G1/4	G3/8	G1/2	G3/4	G1	G1 1/2
Nominal Ø (mm)	5,5	8	10	15	19	25	39
Nominal flow rate (NI/min)	580	1100	1500	5400	6500	13500	35000

### CONSTRUCTIVE CHARACTERISTICS

Valve body	G1/8 ÷ G1 = zamak G1 1/2 = aluminium
Seals	nitrile rubber, polyurethane
Actuators	G1/8 ÷ G1 = zamak G1 1/2 = aluminium
Spool	G1/8 ÷ G3/8 = aluminium G1/2 ÷ G1 1/2 = steel + plastic

### ELECTRIC CHARACTERISTICS

	G1/8 G1/4	G1/4 ÷ G1 1/2
Electropilot	U1	U2
Coil	DA	DB
Power consumption	3,5 W (DC) - 5 VA (AC)	11 W (DC) - 10 VA (AC)
Connector	AM-5110	AM-5111
Voltage	12 V DC - 24 V DC - 24 V AC - 110 V AC - 230 V AC	
Manual override	with 2 position screw	

G1/8 - G1/4 - G3/8 Electrovalves

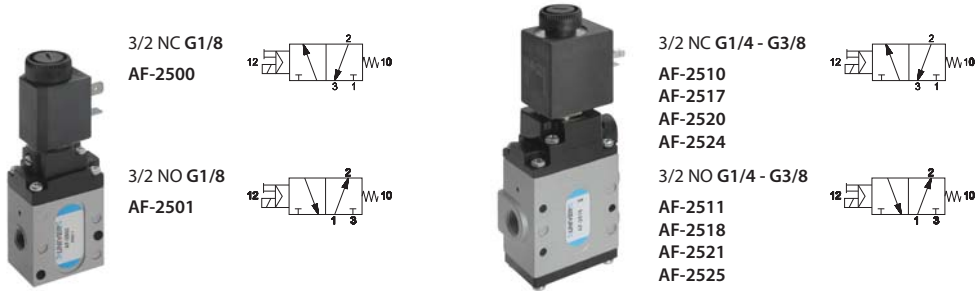

	Connect.	Control	Return	Flow rate (Nl/min)	Ø mm	Times (ms)		Pressure bar		Weight Kg	Coil	Part no.
						En.	De-en.	min.	max.			
3/2 NC	G1/8	electric amplified	pneumomechanical spring	580	5,5	15	20	1,5	10	0,25	U1	AF-2500
	G1/4	electric amplified	pneumomechanical spring	1100	8	20	23	1,6	10	0,58	U1	AF-2510
	G1/4	electric amplified	pneumomechanical spring	1100	8	20	23	1,6	10	0,70	U2	AF-2517
	G3/8	electric amplified	pneumomechanical spring	1500	10	20	23	1,6	10	0,56	U1	AF-2520
	G3/8	electric amplified	pneumomechanical spring	1500	10	20	23	1,6	10	0,70	U2	AF-2524
3/2 NO	G1/8	electric amplified	pneumomechanical spring	580	5,5	15	20	1,5	10	0,25	U1	AF-2501
	G1/4	electric amplified	pneumomechanical spring	1100	8	15	20	1,6	10	0,58	U1	AF-2511
	G1/4	electric amplified	pneumomechanical spring	1100	8	15	20	1,6	10	0,70	U2	AF-2518
	G3/8	electric amplified	pneumomechanical spring	1500	10	15	20	1,6	10	0,56	U1	AF-2521
	G3/8	electric amplified	pneumomechanical spring	1500	10	15	20	1,6	10	0,70	U2	AF-2525

G1/8

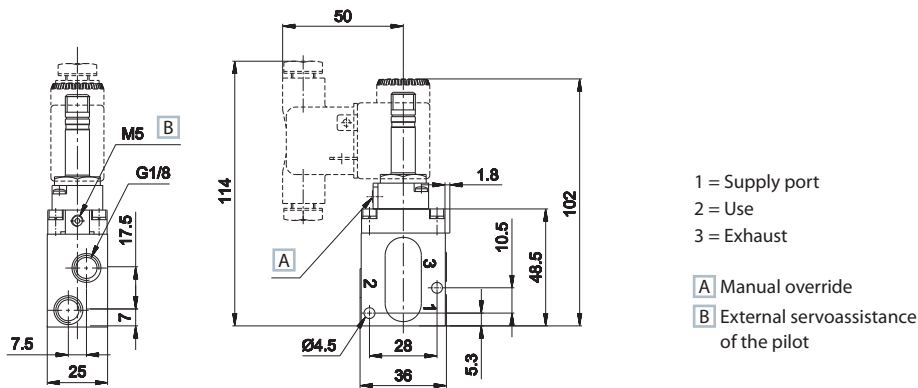

G1/4 - G3/8

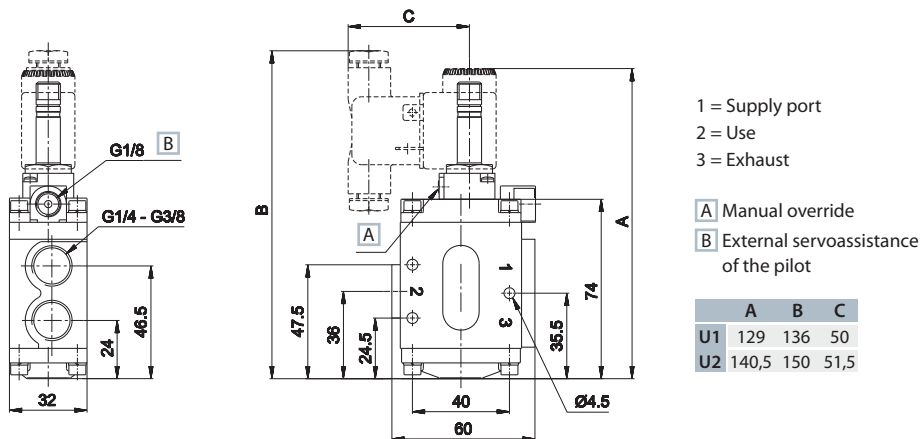

Upon request:

- external servoassistance of the pilot
- G1/4 - G3/8 U2 without manual override

Electrovalves are supplied without coil, connector and locking ring

G1/2 - G3/4 - G1 - G1 1/2 Electrovalves



3/2 NC G1/2 - G3/4 - G1  
 AF-2530  
 AF-2540  
 AF-2545

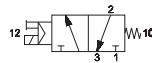

3/2 NC G1 1/2  
 AF-2565

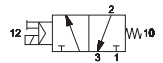

3/2 NO G1/2 - G3/4 - G1  
 AF-2531  
 AF-2541  
 AF-2546

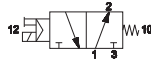

3/2 NO G1 1/2  
 AF-2561

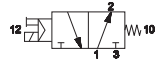

	Connect.	Control	Return	Flow rate (NI/min)	Ø mm	Times (ms)		Pressure bar		Weight Kg	Coil	Part no.
						En.	De-en.	min.	max.			
3/2 NC	G1/2	electric amplified	pneumomechanical spring	5400	15	17	27	2	10	1,19	U2	AF-2530
	G3/4	electric amplified	pneumomechanical spring	6500	19	17	27	2	10	1,13	U2	AF-2540
	G1	electric amplified	pneumomechanical spring	13500	25	20	32	2,2	10	1,62	U2	AF-2545
	G1 1/2	electric amplified	pneumomechanical spring	35000	39	47	22	2,5	10	2,27	U2	AF-2565
3/2 NO	G1/2	electric amplified	pneumomechanical spring	5400	15	30	22	3	10	1,19	U2	AF-2531
	G3/4	electric amplified	pneumomechanical spring	6500	19	30	22	3	10	1,13	U2	AF-2541
	G1	electric amplified	pneumomechanical spring	13500	25	28	23	3	10	1,62	U2	AF-2546
	G1 1/2	electric amplified	pneumomechanical spring	35000	39	55	20	3	10	2,27	U2	AF-2561

G1/2 - G3/4 - G1

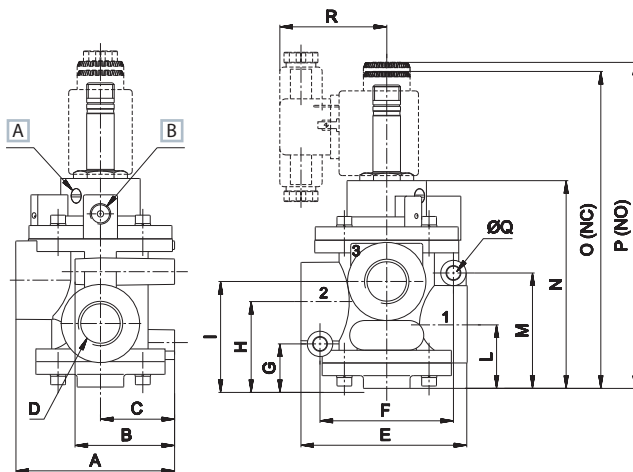

- 1 = Supply port
- 2 = Use
- 3 = Exhaust

- A Manual override
- B External servoassistance of the pilot

	A	B	C	D	E	F	G	H	I	L	M	N	O	P	Q	R
G1/2	75	47	35	G1/2	78,5	63	21	41	50,5	30	54,5	100	150	154	6,4	50,5
G3/4	75	47	35	G3/4	78,5	63	21	41	50,5	30	54,5	100	150	154	6,4	50,5
G1	89	55	40	G1	101	76	25,5	51	64	38	62,5	115	167	175	8,4	50

G1 1/2

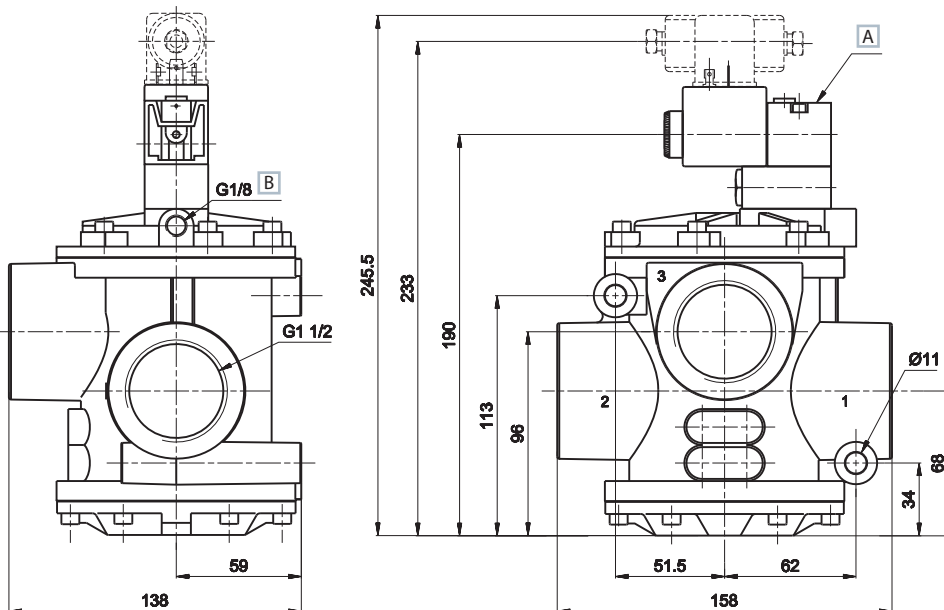

- 1 = Supply port
- 2 = Use
- 3 = Exhaust

- A Manual override
- B External servoassistance of the pilot

Electrovalves are supplied without coil, connector and locking ring

G1/8 - G1/4 - G3/8 Servo valves



3/2 NC G1/8  
AF-2600

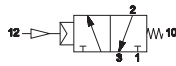

3/2 NO G1/8  
AF-2700

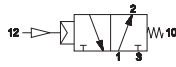

3/2 NC G1/4 - G3/8  
AF-2601  
AF-2606

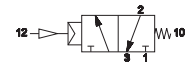

3/2 NO G1/4 - G3/8  
AF-2701  
AF-2706

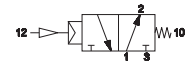

	Connect.	Control	Return	Flow rate (NI/min)	Ø mm	Times (ms)		Pressure bar		Weight Kg	Part no.
						En.	De-en.	supply	control		
3/2 NC	G1/8	pneumatic amplified	pneumomechanical spring	580	5,5	5	8	6	3,5	0,21	AF-2600
	G1/4	pneumatic amplified	pneumomechanical spring	1100	8	5	7	6	4	0,54	AF-2601
	G3/8	pneumatic amplified	pneumomechanical spring	1500	10	5	7	6	4	0,52	AF-2606
3/2 NO	G1/8	pneumatic amplified	pneumomechanical spring	580	5,5	5	8	6	3,5	0,21	AF-2700
	G1/4	pneumatic amplified	pneumomechanical spring	1100	8	5	7	6	4	0,54	AF-2701
	G3/8	pneumatic amplified	pneumomechanical spring	1500	10	5	7	6	4	0,52	AF-2706

G1/8

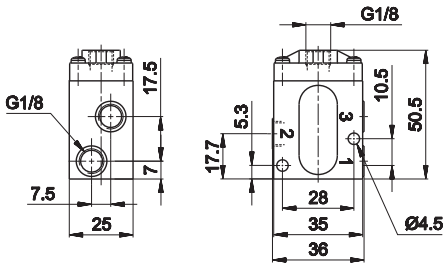

- 1 = Supply port
- 2 = Use
- 3 = Exhaust

G1/4 - G3/8

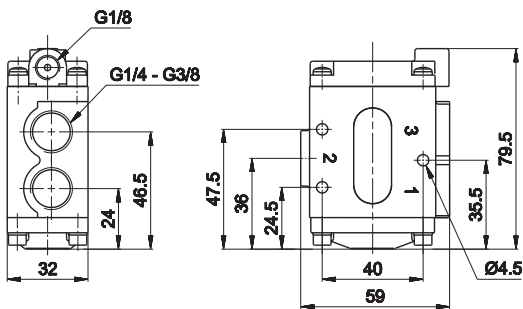

- 1 = Supply port
- 2 = Use
- 3 = Exhaust

G1/2 - G3/4 - G1 - G1 1/2 Servo valves



3/2 NC G1/2 - G3/4 - G1  
 AF-2603  
 AF-2610  
 AF-2615

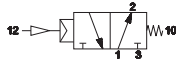
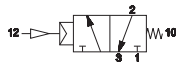

3/2 NO G1/2 - G3/4 - G1  
 AF-2603  
 AF-2610  
 AF-2615



3/2 NC G1 1/2  
 AF-2620

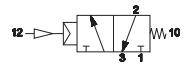

3/2 NO G1 1/2  
 AF-2620

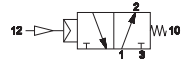

3/2 NC-NO

Connect.	Control	Return	Flow rate (Nl/min)	Ø mm	Times (ms)		Pressure bar		Weight Kg	Part no.
					En.	De-en.	supply	control		
G1/2	pneumatic amplified	pneumomechanical spring	5400	15	7	10	6	4	1,27	<b>AF-2603</b>
G3/4	pneumatic amplified	pneumomechanical spring	6500	19	7	10	6	4	1,10	<b>AF-2610</b>
G1	pneumatic amplified	pneumomechanical spring	13500	25	10	12	6	4	1,59	<b>AF-2615</b>
G1 1/2	pneumatic amplified	pneumomechanical spring	35000	39	36	15	6	4	2,19	<b>AF-2620</b>

G1/2 - G3/4 - G1

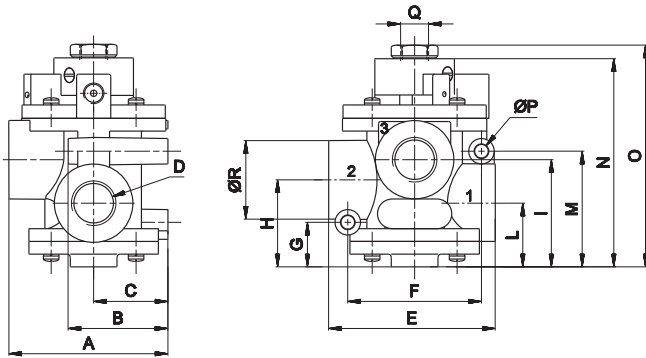

1 = Supply port  
 2 = Use  
 3 = Exhaust

	A	B	C	D	E	F	G	H	I	L	M	N	O	P	Q	R
G1/2	75	47	35	G1/2	78,5	63	21	41	50,5	30	54,5	100	105	6,4	G1/4	37
G3/4	75	47	35	G3/4	78,5	63	21	41	50,5	30	54,5	100	105	6,4	G1/4	37
G1	88,5	55	40	G1	101	76	25,5	51	64	38	62,5	115	120,5	8,4	G1/4	45

G1 1/2

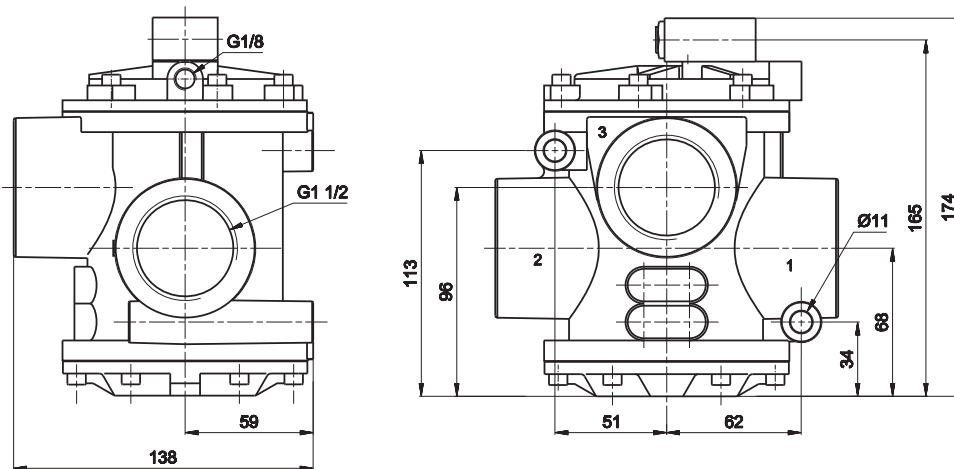

1 = Supply port  
 2 = Use  
 3 = Exhaust

G1 - 2/2 Electrovalve for blowing

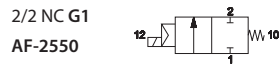

2/2 NC

Connect.	Control	Return	Flow rate (NI/min)	Ø mm	Times (ms)		Pressure bar		Weight Kg	Part no.		
					En.	De-en.	min.	max.			supply	control
G1	electric amplified	pneumomechanical spring	16000	25	23	55	2	10	-	-	1,06	AF-2550
G1	electric amplified	pneumomechanical spring	16000	25	23	55	2	10	-	-	1,06	AF-2551
G1	electric amplified	pneumomechanical spring	16000	25	23	35	-	-	6	4	1,06	AF-2552

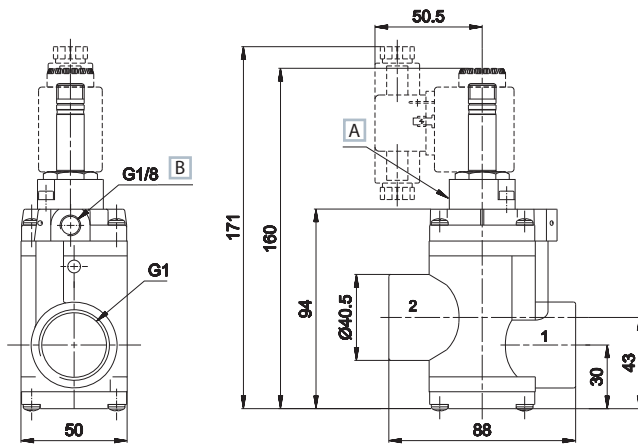

1 = Supply port  
2 = Use

A Manual override AF-2551  
B External servoassistance of the pilot AF-2552

G1 - 2/2 Servovalve for blowing

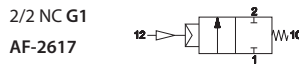

2/2 NC

Connect.	Control	Return	Flow rate	Ø mm	Times (ms)		Pressure bar		Weight Kg	Part no.
					En.	De-en.	min.	max.		
G1	pneumatic amplified	pneumomechanical spring	16000	25	12	25	6	4	1	AF-2617

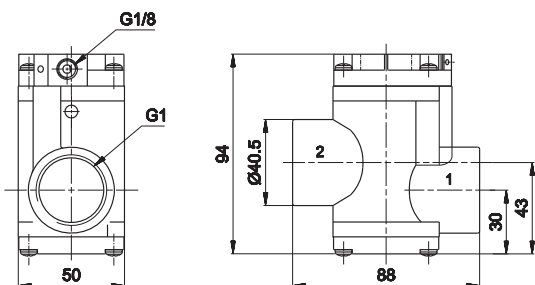

1 = Supply port  
2 = Use

Electrovalves are supplied without coil, connector and locking ring