

CYLINDERS ACM- AND DVM- TECHNICAL FEATURES / CARATTERISTICHE TECNICHE ACM- E DVM-

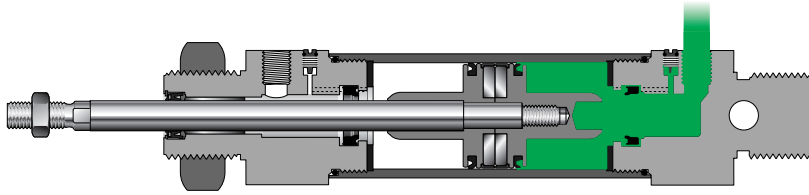

ISO 6432

Ø16; 20; 25

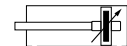

ACM..

Ø12; 16; 20; 25

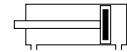

DVM..

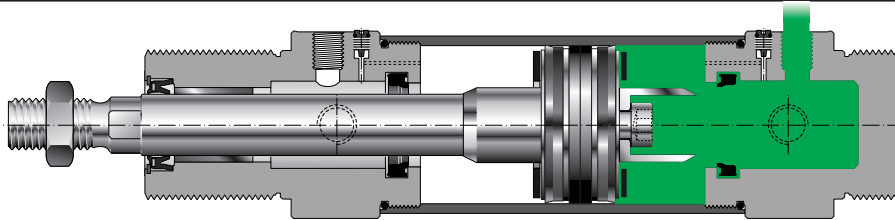

Ø32; 40; 50

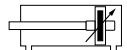

ACMT..

Ø32; 40; 50

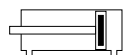

DVMT..

The cushioned double acting Vesta **ACM(T)** cylinders with magnetic pistons and adjustable cushioning are available in the following bore sizes: 16, 20, 25, 32, 40 and 50 in a wide range of standard strokes. The Vesta cylinder type **DVM(T)** is available in diameters of 12, 16, 20, 25, 32, 40 and 50, with mechanical buffers at both ends, and magnetic piston. **ACM(T)** and **DVM(T)** series are built with screw heads. Stroke tolerance follows ISO 6432 standard.

*I cilindri Vesta serie **ACM(T)** a doppio effetto ammortizzati e con pistone magnetico sono disponibili negli alesaggi 16, 20, 25, 32, 40 e 50 mm, in una vasta gamma di corse standard; mentre i cilindri serie **DVM(T)** con smorzatori meccanici d'urto, magnetici, sono disponibili negli alesaggi 12, 16, 20, 25, 32, 40 e 50 mm. Le particolari caratteristiche costruttive, le soluzioni tecniche adottate ed i materiali impiegati, garantiscono una lunga durata ed un ottimo funzionamento del cilindro. La costruzione è del tipo "teste avitate", quindi cilindri ispezionabili con possibilità di manutenzione. I cilindri serie **ACM(T)** e **DVM(T)** sono predisposti per il montaggio di sensori magnetici. Le tolleranze sulle corse dei cilindri sono conformi alla normativa ISO 6432.*

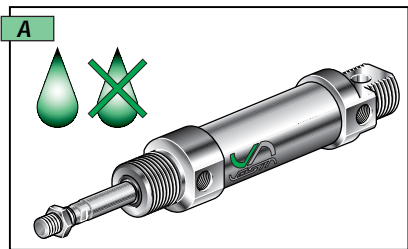

Lubrication not required.
Possibilità di funzionamento continuo privo di lubrificazione.

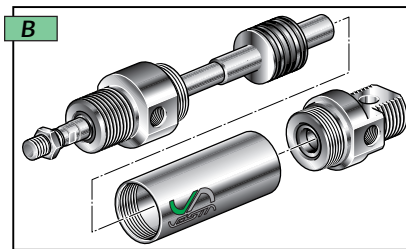

"Screw head" construction allows immediate check up of cylinders.
Le teste filettate consentono di ispezionare agevolmente il cilindro.

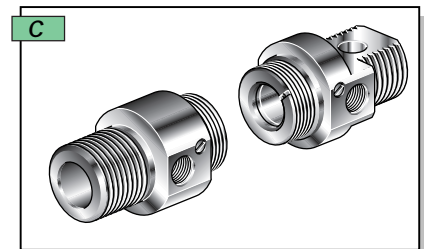

Caps in a light alloy of anodized aluminium.
Le teste sono in lega leggera di alluminio anodizzate.

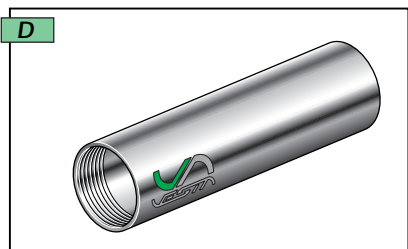

Tubes in anodized aluminium.
Le camicie sono in alluminio anodizzato.

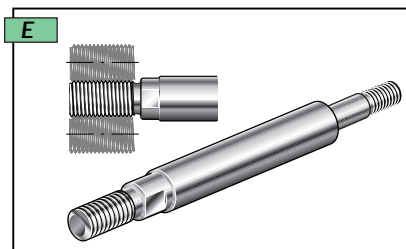

Piston rods in rolled stainless steel X5CrNi 1810 (X20Cr 13 for Ø32,40,50).
Steli in acciaio INOX X5CrNi 1810 rullato (X20Cr 13 per Ø32,40,50 mm).

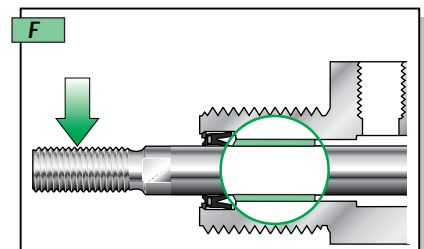

Self lubricating bearing in a copper-steel alloy, with teflon covering.
Boccole autolubrificanti in acciaio ramato con deposito in Teflon.

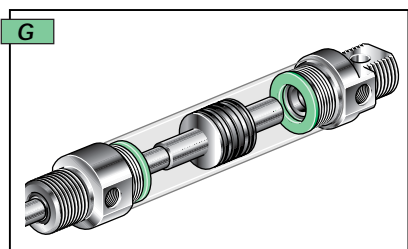

Mechanical buffers at both ends for **DVM** and **DVMT** series.
*Smorzatori d'urto meccanici per **DVM** e **DVMT**.*

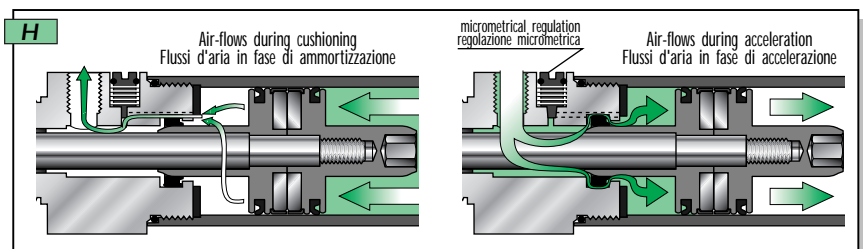

Very efficient and progressive adjustable cushioning for **ACM** and **ACMT** series.
*Ammortizzatori pneumatici progressivi ed efficienti per la serie **ACM** ed **ACMT**.*

PNEUMATIC CYLINDERS WITH MAGNETIC PISTON STANDARD ISO 6432 SERIE **DVM**

CILINDRI PNEUMATICI CON PISTONE MAGNETICO ISO 6432

With magnetic piston / Con pistone magnetico

DVM /

- Bore
Alesaggio (mm):
- Stroke
Corsa (mm):
- VS** Viton rod seal
Guarnizione dello stelo in Viton
- VV** Viton all seal
Tutte le guarnizioni in Viton
- P** Through rod cylinder
Cilindro stelo passante
- SEA** Simple acting front spring
Cilindro semplice effetto molla anteriore
- SEP** Simple acting rear spring
Cilindro semplice effetto molla posteriore
- Ø12 **12**
- Ø16 **16**
- Ø20 **20**
- Ø25 **25**

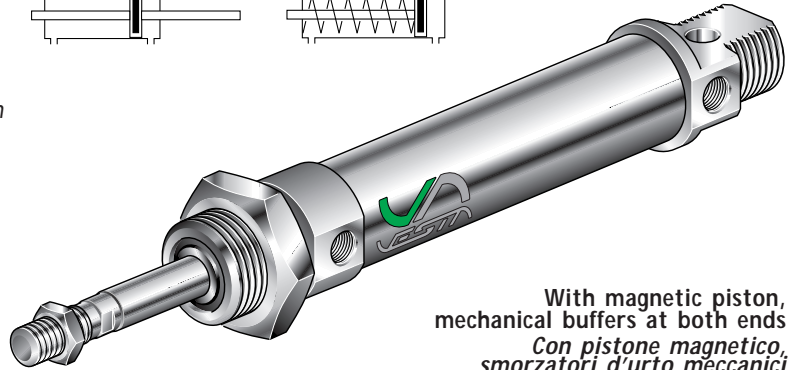
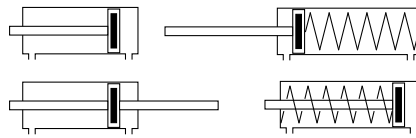

With magnetic piston,
mechanical buffers at both ends
Con pistone magnetico,
smorzatori d'urto meccanici

ISO 6432 cylinder fixing see:
Fissaggi per cilindri ISO 6432 vedi: **Pag. A-10 ÷ A-11.**

Characteristic reed switches see:
Caratteristiche finecorsa magnetici: **Pag. A-11, A-19.**

Bore Alesaggio	Standard stroke / Corse Standard													
	10	25	50	80	100	125	160	200	250	300	350	400	450	500
12	•	•	•	•	•	•	•	•	•	•	•	•	•	•
16	•	•	•	•	•	•	•	•	•	•	•	•	•	•
20	•	•	•	•	•	•	•	•	•	•	•	•	•	•
25	•	•	•	•	•	•	•	•	•	•	•	•	•	•

- End caps Anodized aluminium.
- Piston rod Rolled burnished stainless steel X5CrNi 1810.
- Barrel Anodized aluminium.
- Seals NBR rubber.
- Cushoning Mechanical buffers.

- Environment temperature range -10 °C ÷ +80 °C.
- Temperature range of medium 0 °C ÷ +40 °C.
- Lubrication Not required.
- Medium Filtered air.
- Max operating pressure 10 bar.

- Testate Alluminio anodizzato.
- Stelo Acciaio inox X5CrNi 1810 rollato.
- Camicia Alluminio anodizzato.
- Guarnizioni Tutte in NBR.
- Ammortizzatori Meccanici in poliuretano.

- Temperatura ambiente -10 °C ÷ +80 °C.
- Temperatura fluido 0 °C ÷ +40 °C.
- Lubrificazione Non necessaria.
- Fluido Aria filtrata.
- Pressione max d'esercizio 10 bar.

TECHNICAL FEATURES

CARATTERISTICHE TECNICHE

* = Stroke / Corsa

Bore Alesaggio	A	ØB	C	CH	D	ØE ^{H9}	F	G	I	L	ØM	N	ØO	ØP	R	Code Codice
12	75	18	17,2	5	15	6	16	22	12	7	M6x1	9	M16x1,5	M5	22	DVM 12/...
16	82	22	21,2	5	15	6	16	22	12	7	M6x1	9	M16x1,5	M5	22	DVM 16/...
20	95	28	26,2	7	19	8	20	24	16	5	M8x1,25	12	M22x1,5	G1/8	30	DVM 20/...
25	104	34	32,5	8	20	8	22	28	16	8	M10x1,25	12	M22x1,5	G1/8	30	DVM 25/...

SINGLE ROD / CILINDRO BASE STELO SEMPLICE **DVM .. /...**

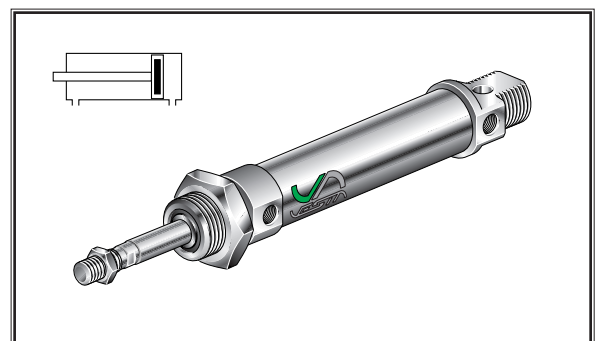

* = Stroke / Corsa

Bore Alesaggio	A	ØB	C	CH	D	F	G	L	ØM	ØO	ØP	Code Codice
12	49,5	18	17,2	5	15	16	22	7	M6x1	M16x1,5	M5	DVM 12/... P
16	56	22	21,2	5	15	16	22	7	M6x1	M16x1,5	M5	DVM 16/... P
20	68	28	26,2	7	19	20	24	5	M8x1,25	M22x1,5	G1/8	DVM 20/... P
25	69	34	32,5	8	20	22	28	8	M10x1,25	M22x1,5	G1/8	DVM 25/... P

THROUGH ROD / STELO PASSANTE **DVM .. /... P**

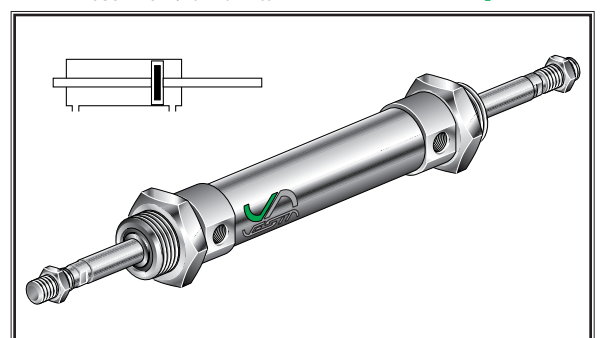



DVM .. /... SEA SIMPLE ACTING FRONT SPRING SEMPLICE EFFETTO MOLLA ANTERIORE

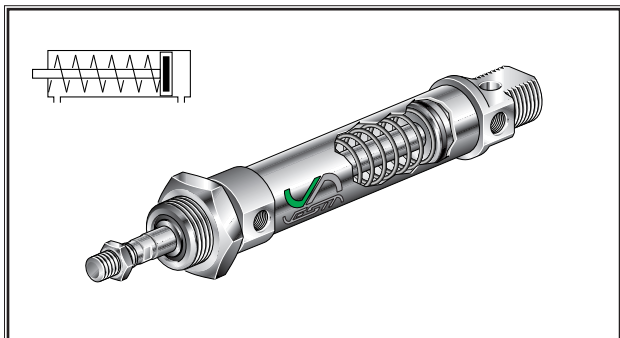

For overall dimensions see DVM single rod
Dimensioni di ingombro vedi DVM base stelo semplice

* = Stroke / Corsa

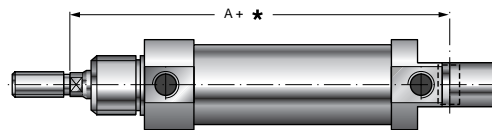

Bore Alesaggio	A	Code Codice
12	75	DVM 12/... SEA
16	82	DVM 16/... SEA
20	95	DVM 20/... SEA
25	104	DVM 25/... SEA

DVM .. /... SEP SIMPLE ACTING REAR SPRING SEMPLICE EFFETTO MOLLA POSTERIORE

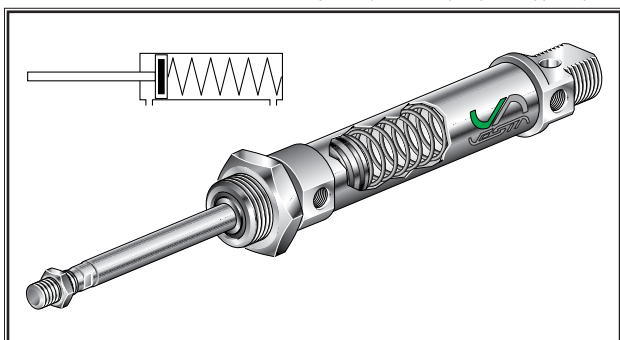

For overall dimensions see DVM standard
Dimensioni di ingombro vedi DVM standard

* = Stroke / Corsa

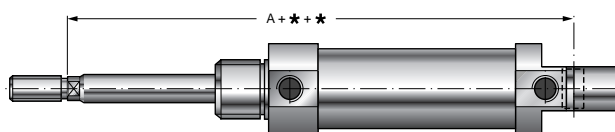

Bore Alesaggio	A	Code Codice
12	75	DVM 12/... SEP
16	82	DVM 16/... SEP
20	95	DVM 20/... SEP
25	104	DVM 25/... SEP

Strokes Corse (mm)	Ø12 mm		Spring force - Forza molla (daN)				Ø25 mm		..SEA	..SEP
	Min.	Max.	Ø16 mm		Ø20 mm		Min.	Max.		
10	2,1	2,4	2,2	2,5	2,3	2,6	2,3	2,6	•	•
25	1,6	2,4	1,6	2,5	1,7	2,6	1,7	2,6	•	•
50	0,35	2,4	0,5	2,5	1	2,6	1	2,6	•	•

..... - SG SEALS KIT / KIT GUARNIZIONI DI RICAMBIO

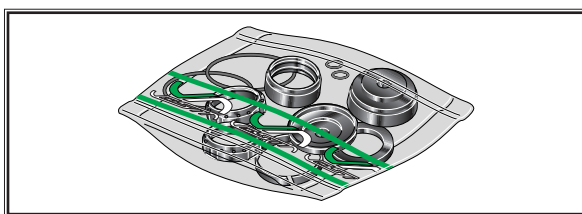

Seals kit code = **Cylinder code + Bore + Versions + - SG:**
(The kit includes all seals).

Codice del kit = **Codice del cilindro + Alesaggio + Versions + - SG:**
(Il kit comprende tutte le guarnizioni necessarie).

Example / Esempio: **DVM 16 VS - SG**



FIXING ACCESSORIES / ACCESSORI DI FISSAGGIO PER CILINDRI ISO 6432

Fixing accessories in steel grant a correct mounting for all usage of the Vesta cylinders. (Note: the fixing screws are not included in the supply of the fittings)

Gli accessori di fissaggio garantiscono montaggi stabili e resistenti alle sollecitazioni. Sono realizzati in acciaio per soddisfare ogni possibile tipo di impiego. (Nota: le viti di fissaggio non sono comprese nella fornitura degli accessori.)

AS/.. REAR HINGE HORIZONTAL MOUNTING MONTAGGIO A CONTROCERNIERA

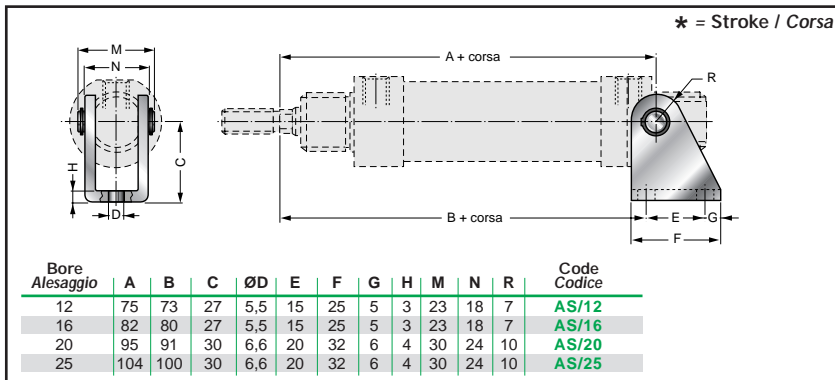
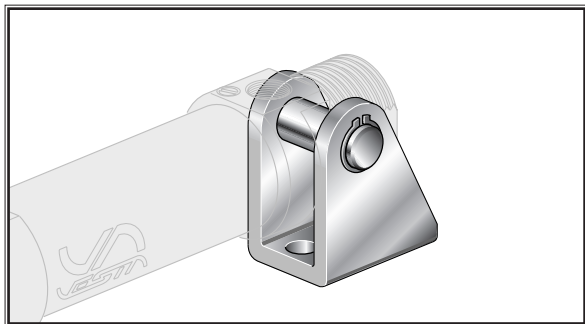

FL/.. FLANGE MOUNTING MONTAGGIO A FLANGIA

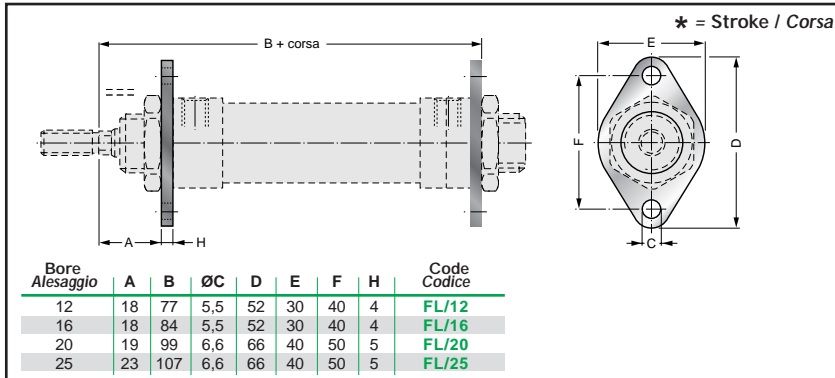
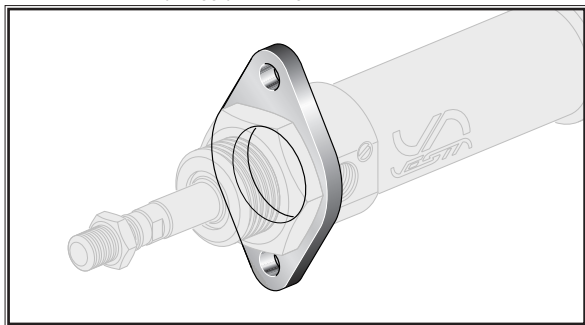

P/.. FOOT MOUNTING MONTAGGIO A PIEDINI

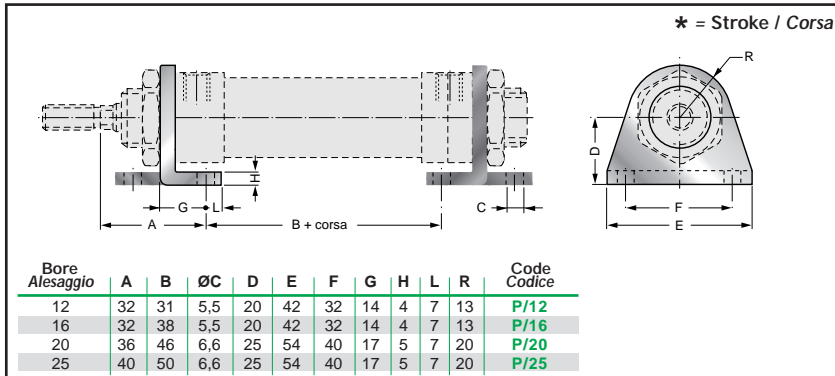
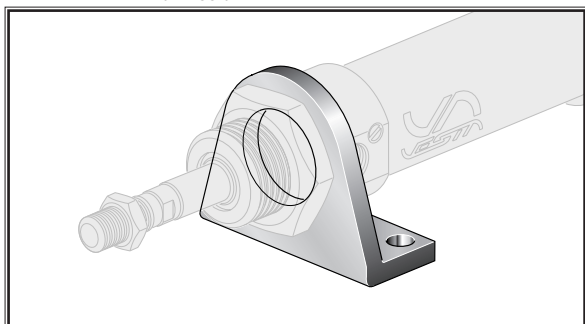

SAS/.. FLOATING JOINT TYPE "S" SNODO AUTOALLINEANTE

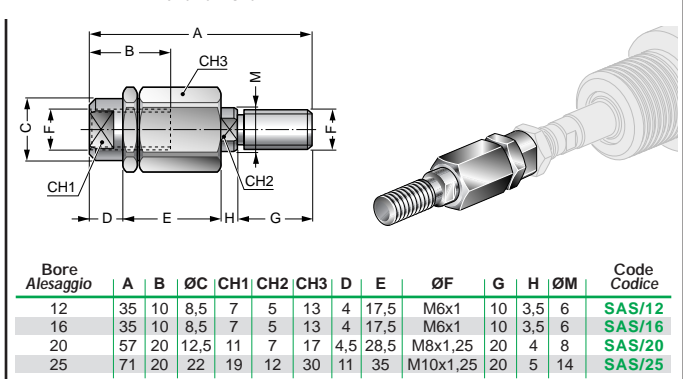

SNS/.. ROD EYE MOUNTING SNODO SFERICO

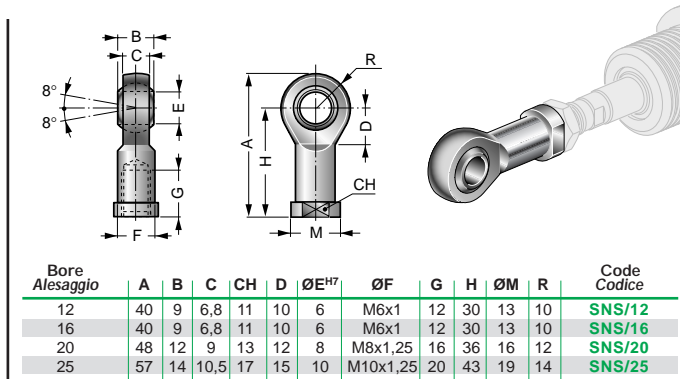

CLEVIS (ROD) MOUNTING
FORCELLA STELO **FS/..x..**

Bore Alesaggio	A	B	B3	C ^{B12}	D	E	ØF	ØG	H	ØI ^{H9}	Code Codice
12	31	12	16	6	12	9	M6x1	10	24	6	FS/6x1
16	31	12	16	6	12	9	M6x1	10	24	6	FS/6x1
20	42	16	22	8	16	12	M8x1,25	14	32	8	FS/8x1,25
25	52	20	26	10	20	15	M10x1,25	18	40	10	FS/10x1,25

CAP NUT
DADO TESTATA **DM../..**

Bore Alesaggio	CHD	SD	ØF	Code Codice
12	24	8	M16x1,5	DM12/16
16	24	8	M16x1,5	DM12/16
20	32	10	M22x1,5	DM20/25
25	32	10	M22x1,5	DM20/25

ROD NUT
DADO STELO **DS../..**

Bore Alesaggio	CHD	SD	ØF	Code Codice
12	10	4	M6x1	DS12/16
16	10	4	M6x1	DS12/16
20	13	5	M8x1,25	DS/20
25	17	6	M10x1,25	DS/25

MAGNETIC SWITCHES FOR ISO 6432 CYLINDER / FINECORSIA MAGNETICI PER CILINDRI ISO 6432

FFS **VS**

Bore
Alesaggio
(mm):
Ø12 ... **12**
Ø16 ... **16**
Ø20 ... **20**
Ø25 ... **25**

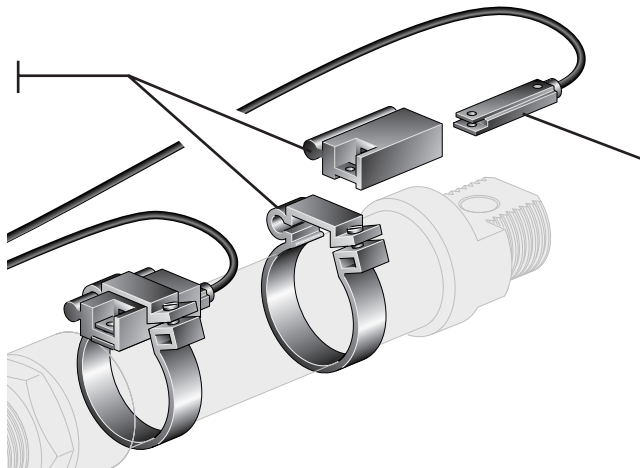

For magnetic switches features see:
Caratteristiche finecorsa magnetici vedi:

**VSCR2, VSPR2,
VSCE3, VSPE3.**

Pag. A-19

MAGNETIC SWITCH POSITIONING / POSIZIONAMENTO DEI FINECORSIA MAGNETICI

