

KANTHAL SUPER

Electric
Heating Element
Handbook

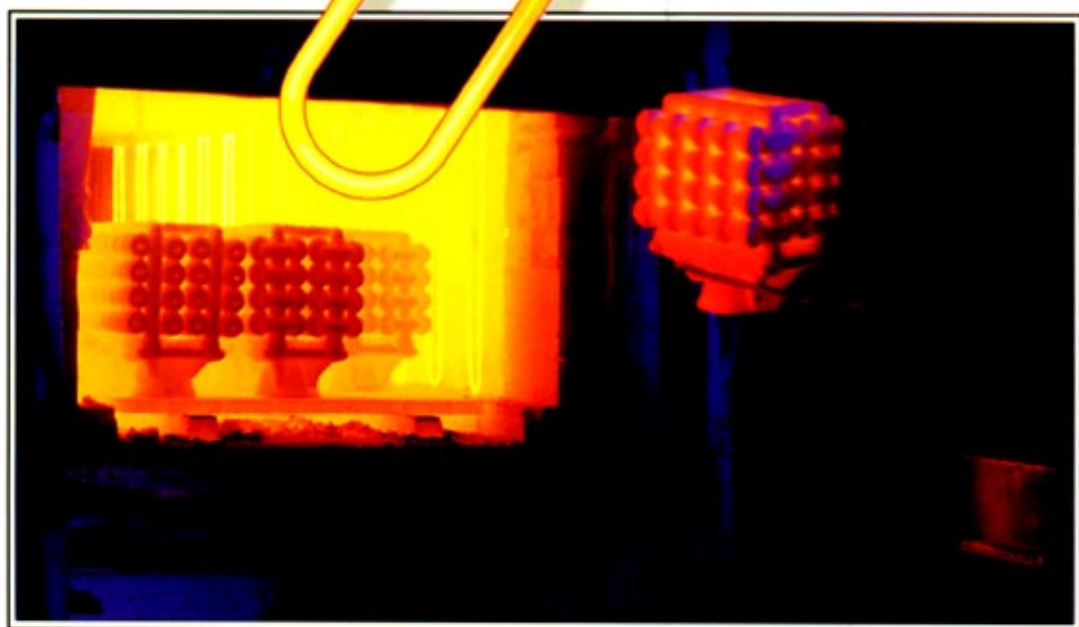

Copyright by Kanthal AB.

May be reproduced
only with proper acknowledgement
of the source.

Catalogue 2-A-1-3

ISBN 91 86720 08-2

5000 05.99

Edit by Texter med Tryck AB Hallstahammar.

Design and set in DTP by
Mediaidé, Eskilstuna. (180)

Printed in Sweden by
PRIMAtryck, Hallstahammar, 1999.

This information, which may be subjected to change, is offered solely for your consideration and should not be taken as a warranty or representation for which we assume legal responsibility. It is not to be understood as permission or recommendation to practice a patented invention without a licence and the user should determine whether relevant patents exist.

® KANTHAL is a registered trademark of Kanthal Group companies in Sweden and other countries.

™ SUPERTHAL.

KANTHAL[®]

SUPER

Electric
Heating Element

Handbook

KANTHAL

KANTHAL AB

P O Box 502

SE 734 27 Hallstahammar, Sweden

Telephone: + 46 220 210 00

Fax : +46 220 211 92

www.kanthal.com

A Sandvik Company

Kanthal AB, Hallstahammar, Sweden.



KANTHAL is a world-renowned name within the field of electric heating and you will find our handbook an indispensable aid when installing and operating our KANTHAL SUPER resistance elements that are designed for all types of electric heated industrial furnaces.

When we introduced the now world-famous KANTHAL iron-chromium-aluminium electric resistance alloys in the early thirties this represented a considerable rise in the maximum operating temperature of metallic resistance elements.

Again, when KANTHAL SUPER elements were introduced in 1956, this represented a step upwards on the temperature scale for resistance elements.

The aim of our R&D department, however, has always been to improve our materials to enable their use at still higher temperatures.

Through intense research work, we have been able to raise this temperature from 1650 °C (3000 °F) element temperature in 1956, to 1850 °C (3360 °F) today.

New element forms have also been developed and in this handbook you will find information about SUPERTHAL high temperature heating modules.

KANTHAL SUPER elements have proved to be very useful not only at high furnace temperatures, but also at lower temperatures, particularly in the field of heat treatment of metallic products in controlled atmospheres and melting of glass.

The fields of possible applications are unlimited and have yet to be fully investigated. With the increasing interest in electric heating, we can expect many new designs and applications in the future.

In addition to information on the properties of our KANTHAL SUPER material this handbook will also provide data on our standard elements and instructions for element calculation, installation, operation, etc. Further, advice is given on furnace designs, and some examples of actual KANTHAL SUPER element installations are shown in the installation section.

We have tried to give you enough information to enable you to calculate and install KANTHAL SUPER elements and how to operate furnaces. If our advice is followed, you will be assured of an efficient and economical installation for your special heat treatment operations.

If you need any further advice, specialists at our companies, our agents and the skilled staff at our technical service department in Hallstahammar will be pleased to assist you.

Preface	5
1 Introduction	9
This is KANTHAL SUPER	9
Quality and product summary	10
2 Properties	11
Mechanical and physical properties	11
Chemical resistance	12
3 Elements and tubes	17
Two-shank elements	17
Terminal shapes	18
Two-shank bent elements	20
Four-shank 1700 elements for horizontal use	20
Tubes	22
4 SUPERTHAL heating modules	25
Basic data for SUPERTHAL (Table 6)	27
Temperature-loading diagram	28
SUPERTHAL terminal design	29
5 Electrical data	33
6 Performance	63
Resistivity	63
Temperature-loading diagram, KANTHAL SUPER 1700 and 1800	64
Temperature-loading diagram, KANTHAL SUPER 1900	65
Wall loading	66
7 Installation	67
Vertically mounted elements	67
Horizontally mounted elements	67
Brick lined furnaces	68
Ceramic fibre lined furnaces	69
Element holders and anchor systems	74
Contacts	78
Assembling of KANTHAL SUPER elements	80
Assembling of SUPERTHAL furnaces	85
Elements in radiant tubes	86
8 Calculations	87
Examples of element calculations	94

9	Control, power supply and wiring	107
	Material characteristics	107
	Control in general	107
	Thyristor control	108
	Phase-angle firing	108
	Burst firing with phase-angle start	109
	On/off control	110
	Tapped transformer	110
	Contactors switch, changing the element connection	111
	Scott-connected transformers	114
	Calculation of transformers	114
	Wiring to counteract electromagnetic forces	115
10	Furnace operation	121
	Initial start-up procedure recommendations	121
	Starting up a newly-built furnace	121
	Replacement of elements	122
	Temperature control	122
	Standard platinum-platinum/rhodium thermocouples	123
11	Appendix 1	125
	Accessories	125
	Element size 3/6 and 4/9	125
	Element size 6/12	127
	Element size 9/18	130
	Element size 12/24	132
	Anchor systems	134
	Passage bricks	136
	Other accessories	139
12	Appendix 2	145
	Troubleshooting	145
	Temperature colour	146
	Resistivity as a function of temperature for some resistor materials and for copper	147
	Physical data, gases	148
	Content of water, gases	148
	Average theoretical heat storage in kW/t for some common metals	149
	Physical data, metals	150
	Temperature conversion table	152
	Miscellaneous conversion factors	154
	Thermocouples	156
	Intensity of black body radiation	157
	Relative intensity of radiation of KANTHAL SUPER	158
	Heat transfer by radiation	159
	Calculation of furnace insulation	160

Fig. 1 Range of KANTHAL SUPER 6/12, 9/18, 12/24 elements and SUPERTHAL heating modules.

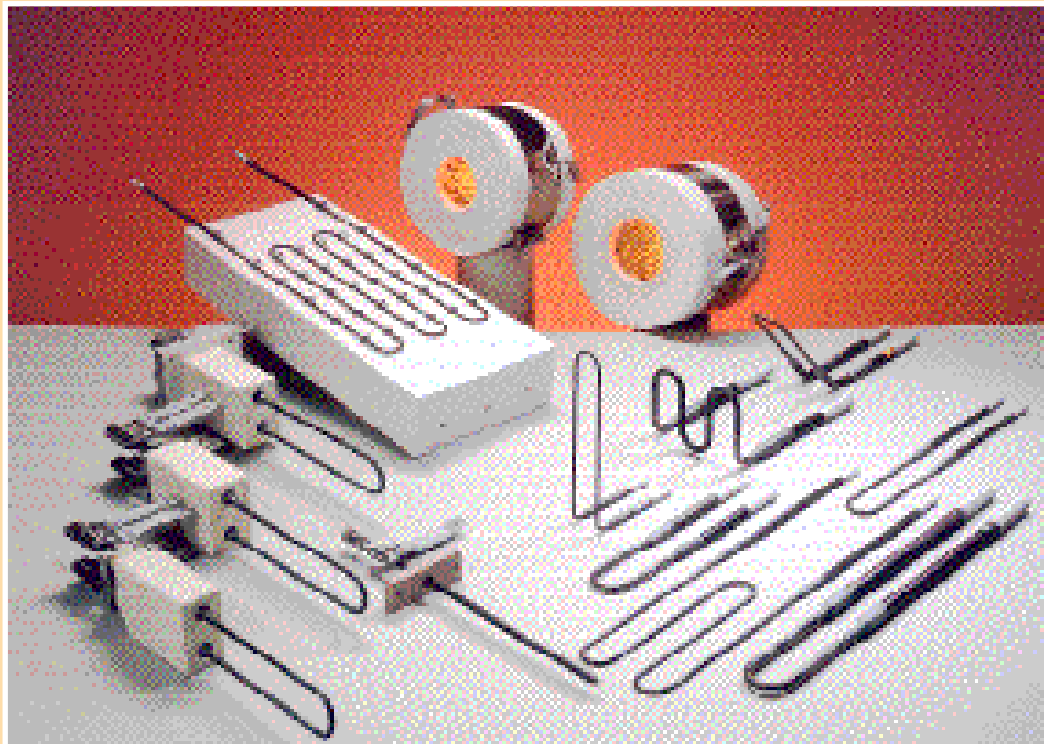
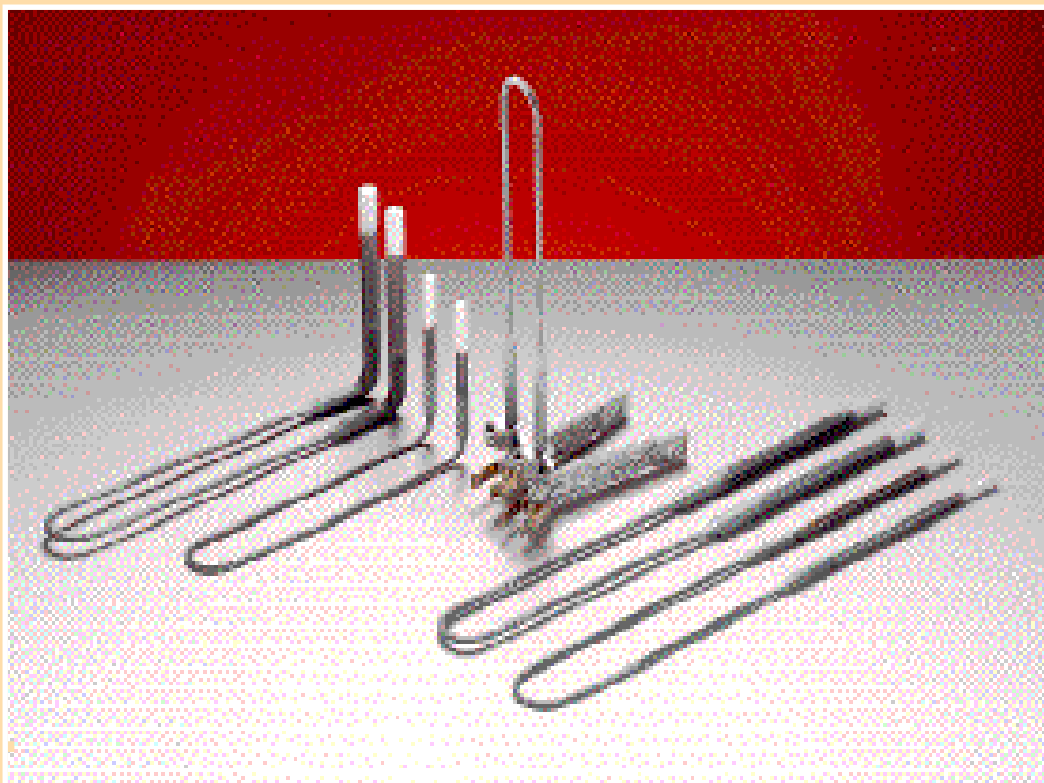

Fig. 2 Range of KANTHAL SUPER 3/6 and 4/9 elements.



Introduction

1

This is KANTHAL SUPER

Composition

KANTHAL SUPER is a dense cermet material consisting of MoSi_2 and an oxide component, mainly a glass phase.

KANTHAL SUPER has the ability to withstand oxidation at high temperatures. This is due to the formation of a thin and adhesive protective layer of quartz glass on the surface. When MoSi_2 reacts with oxygen in the atmosphere, the layer of quartz glass is formed and under this a thin layer of molybdenum silicide with a lower silicon content Mo_5Si_3 .

When KANTHAL SUPER elements are operated at temperatures around $1200\text{ }^\circ\text{C}$ ($2190\text{ }^\circ\text{F}$) the material becomes ductile, whilst at lower temperatures the material is more brittle.

The silica layer possesses the capacity to clean itself from adhering impurities. If the impurities react with silica, the melting point will be lowered. The contaminated layer then flows down the element and drops off. A new silica layer is, however, spontaneously rebuilt.

The unique properties

1. The elements may be used in an oxidizing atmosphere up to an element temperature of $1850\text{ }^\circ\text{C}$ ($3360\text{ }^\circ\text{F}$).
2. Long life combined with ease of replacing failed elements contributes to a high degree of utilization of the furnace and low maintenance costs.
3. New and old elements can be connected in series.
4. High power concentration may be applied.
5. Can be used continuously or intermittently.
6. Fast ramping.

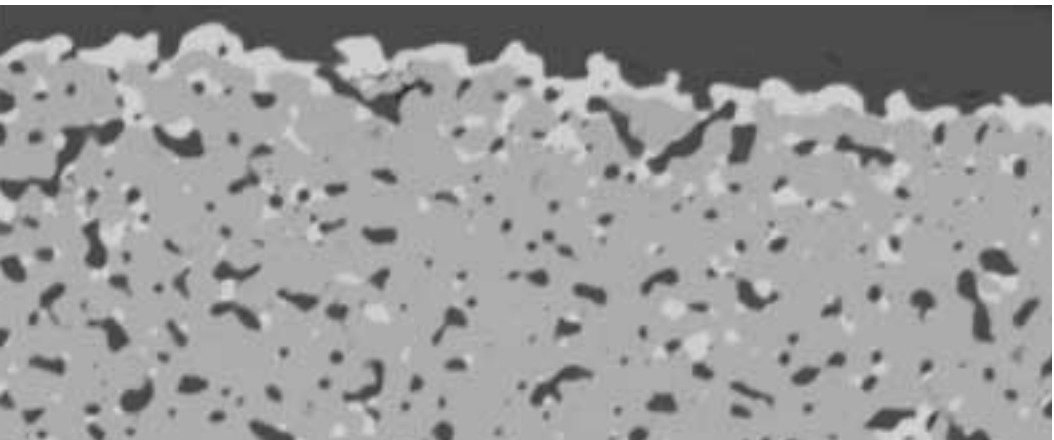

Fig. 3 Microstructure of a KANTHAL SUPER element. Grey = MoSi_2 . White = Mo_5Si_3 , Dark = SiO_2 .

1

Quality and product summary

Type of element	Max. element temperature in air	General applications
<p>KANTHAL SUPER 1700</p> 	<p>1700 °C (3090 °F)</p>	<p>Most types of industrial furnaces for heat treatment forging, sintering, glass melting and refining and for use in radiant tubes.</p>
<p>KANTHAL SUPER 1800</p> 	<p>1800 °C (3270 °F)</p>	<p>Laboratory furnaces, testing equipment and high temperature sintering production furnaces.</p>
<p>KANTHAL SUPER 1900</p> 	<p>1850 °C (3360 °F)</p>	<p>Laboratory furnaces, testing equipment and high temperature sintering furnaces.</p>
<p>SUPERTHAL SMU/SHC</p> 	<p>1600 °C (2910 °F) 1650 °C (3000 °F) KANTHAL Super Excel</p>	<p>Laboratory furnaces, testing equipment, tube furnaces, diffusion furnaces and glass feeders.</p>

Properties

Introduction

KANTHAL SUPER is a unique material combining the best properties of metallic and ceramic materials.

Like metallic materials it has good heat and electric conductivity and like ceramics it withstands corrosion and oxidation and has a low thermal expansion.

It is not affected by thermal shock and is strong enough to withstand many years of service as a heating element.

Resistivity

The resistivity of KANTHAL SUPER increases sharply with temperature. This means that when the elements are connected to a constant voltage, the power will be higher at lower temperatures and will be gradually reduced with increasing temperature, thus shortening the time for the furnace to reach operating temperature. Furthermore, as the power of the elements decreases, the danger of overheating will be reduced.

The resistance of KANTHAL SUPER elements does not change due to ageing even after having been in operation for a long time at high temperatures. There is only a slight reduction ($\approx 5\%$) during the first period of time.

Due to these properties a failed element can easily be replaced without the performance of other elements connected in series being influenced.

See page 63, Fig. 26, Resistivity for KANTHAL SUPER 1700, 1800 and 1900.

Mechanical and physical properties

Tensile strength at 1550 °C (2820° F)	100 Mpa \pm 25%
Bending strength at 20 °C (68° F)	450 Mpa \pm 10%
Compression strength at 20 °C (68° F)	1400-1500 Mpa
Fracture Toughness, K_{IC} , at 20 °C (68° F)	3-4 Mpa $m^{1/2}$
Hardness, HV, at 20 °C (68° F)	9 Gpa
Density, KS 1700 and KS 1800	5.6 g/cm ³
Density, KS 1900	6.5 g/cm ³
Porosity	< 1 %

Thermal conductivity:

20 - 600 °C (68 - 1110° F)	30 W m ⁻¹ K ⁻¹
600 - 1200 °C (1110 - 2190° F)	15 W m ⁻¹ K ⁻¹
Coefficient of linear expansion	7-8 · 10 ⁻⁶ K ⁻¹
Specific heat capacity at 20 °C (68° F)	0.42 kJ kg ⁻¹ K ⁻¹
Emissivity	0.70 - 0.80
Resistivity as a Function of Temperature, C_t	See page 63, Fig 26.

Table 1 The mechanical and physical properties of the KANTHAL SUPER electric heating material.

2

Chemical resistance

Atmospheres

KANTHAL SUPER can be used in most furnace atmospheres. Most favourable are oxidizing atmospheres such as air, carbon dioxide and water vapour, but KANTHAL SUPER elements are also operating successfully in neutral, reducing and carburizing atmospheres.

Table 2 indicates the maximum recommended element temperatures in some common types of furnace atmospheres and gases.

Air

At low temperatures, an oxidation of molybdenum and silicon on the surface of the elements can occur at temperatures around 500 °C (930 °F). The oxidation product is a yellowish powder, M_0O_3 and has normally no detrimental effect on the performance of KANTHAL SUPER elements.

Water vapour and carbon dioxide

Water vapour and carbon dioxide in any amount in the atmosphere have an oxidizing effect. The presence of water vapour in a controlled atmosphere increases the maximum permissible operating temperature

Sulphur dioxide

This gas sometimes occurs as an impurity in the atmosphere. It normally has no harmful effect on KANTHAL SUPER elements.

KANTHAL SUPER element	1700		1800		1900	
	°C	°F	°C	°F	°C	°F
Atmosphere						
Air	1700	3090	1800	3270	1850	3360
Nitrogen	1600	2910	1700	3090	1800	3270
Argon, Helium	1600	2910	1700	3090	1800	3270
Dry hydrogen, dewpoint -80 °C (-112 °F)	1150	2100	1150	2100	1150	2100
Moist hydrogen, dewpoint 20 °C (68 °F)	1450	2640	1450	2640	1450	2640
Endogas (Ex. 40% N ₂ , 40% H ₂ , 20% CO)	1400	2550	1450	2640	1450	2640
Cracked and partially burnt ammonia	1400	2550	1400	2550	1400	2550

Table 2 Maximum recommended element temperatures in atmospheres.

Endogas

A typical gas composition is: 20% CO, 40% H₂ and balance N₂. Since hydrogen is present in this gas composition, the dewpoint and gas velocity are important for determining the maximum temperature.

Carburizing atmosphere

KANTHAL SUPER elements are widely used in carburizing furnaces. The elements are not attacked by the atmosphere which normally consists of an endogas or nitrogen with controlled additions of a carburizing gas such as propane or methanol.

In this type of furnace, the element temperature is normally kept below 1400 °C (2550 °F). If carbon is built up in the furnace because of high carbon potential, it can lead to element failure. Regular removal of the carbon by firing the furnace under oxidizing conditions is recommended.

Nitrogen atmosphere

Nitrogen is used for different purposes such as:

- Nitration of ceramics (reaction)
- Protective gas
- Balancing furnace atmospheres

In the element temperature range of 1250-1550 °C (2280-2820 °F), nitration of ceramics usually occurs. At such temperatures, when the protective glaze is consumed, silicon in the silicide of the element may react with nitrogen forming silicon nitride (Si₃N₄), which could damage the element by scaling. The elements to be used for this purpose should be specially heat treated by Kanthal in order to reduce nitrogen penetration into the material. This treatment is always advisable when operating in nitrogen and when the dewpoint is low.

With operation below 1250 °C (2280 °F) element temperature the reaction is minor. Above 1500 °C (2820 °F) up to 1700-1800 °C (3090-3270 °F) the performance of the element very much depends on dewpoint and time at temperature. In cyclic conditions where the time at temperature is short, the oxide layer on elements can be restored by operating for a short time in air.

When operating for extended periods at temperature (continuous furnaces), the actual formation of a thin layer of Si₃N₄ at the surface of the elements, offers the best protection against further gaseous reaction. When special heat treatment is recommended, it can usually be performed in the furnace where the elements are installed, by operating them in air above

2

Noble gases, argon and helium

These gases are inert and do not react chemically with KANTHAL SUPER. However, if there is a gas flow around the elements, it will disturb the chemical equilibrium existing around the elements. At high temperatures the glaze is consumed. When using these gases, a regeneration of the glaze is recommended before the old glaze has disappeared completely.

Hydrogen

In dry hydrogen the silica layer is reduced and MoSi_2 disintegrates by forming gaseous silicon and silicides with lower silicon content. This reaction is dependent on temperature and the reduction potential of the hydrogen gas. By increasing the dewpoint the maximum permissible element temperature can be increased (Fig. 4). Installation of the elements in niches can reduce the gas flow around the elements, and this can help to reduce the chemical attacks.

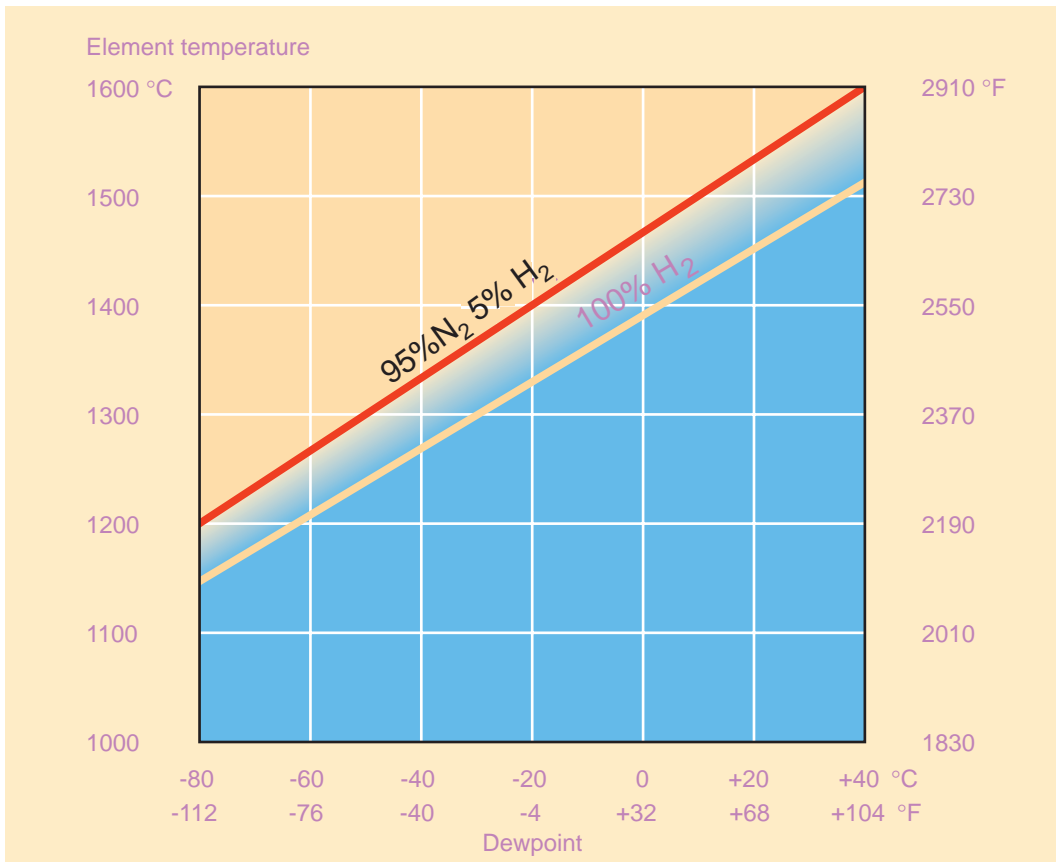

Fig. 4 Maximum element temperature in hydrogen atmospheres (All KANTHAL SUPER qualities).

Nitrogen and hydrogen

This mixture of these gases should be considered as hydrogen. Although nitrogen reduces the reactivity of hydrogen, the effect of hydrogen is considerable, especially with extended periods in operation. The dewpoint of the gas mixture and the gas velocity are always very important (See diagram Fig. 4, page 14). Special heat treatment will improve the performance.

Fluorine and chlorine

These halogens attack KANTHAL SUPER strongly, even oxidized elements, already at temperatures below 600 °C (1110 °F). Both fluorine and chlorine can be formed by dissociation of organic compounds, which may often enter the furnace together with unclean products.

Vacuum

KANTHAL SUPER elements are not suitable for operation in a high vacuum at high temperatures due to silica vaporization. Fig. 5 shows the maximum permissible element temperatures at different air pressures.

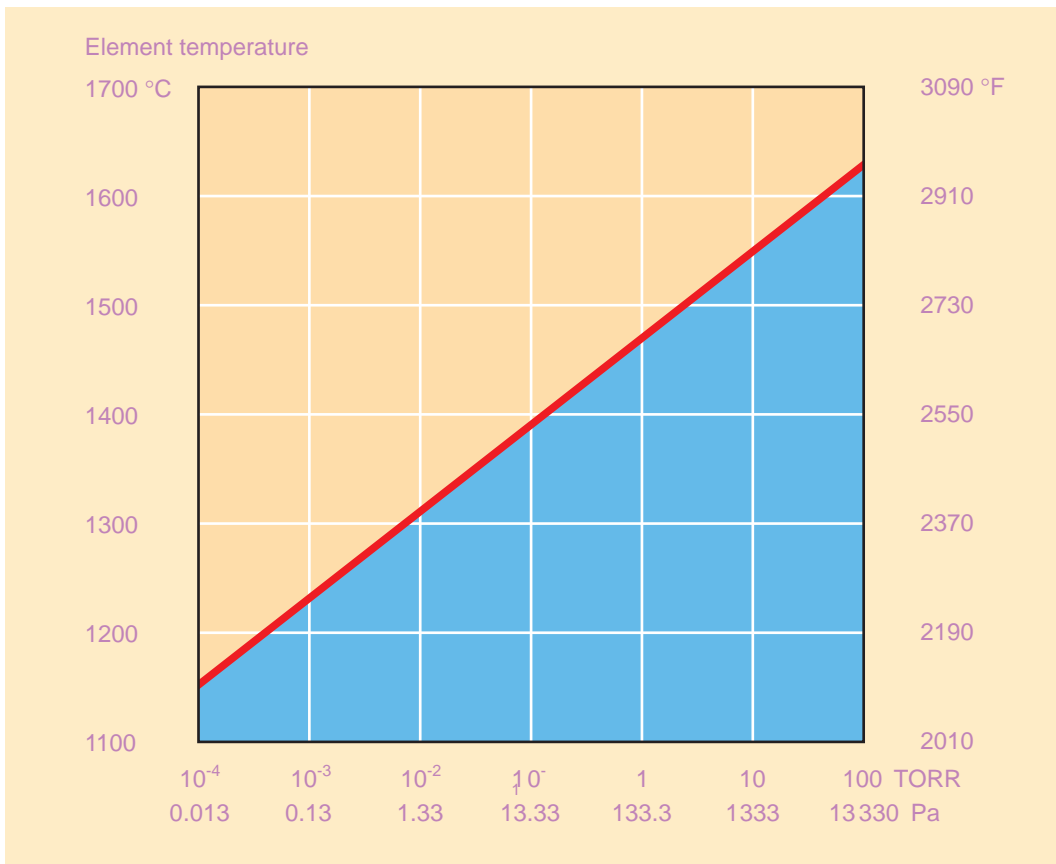

Fig. 5 Maximum element temperatures in vacuum (All KANTHAL SUPER qualities).

2

Metals

All metals in direct contact with KANTHAL SUPER react with MoSi_2 , forming silicides. At higher furnace temperatures, vapours from molten metal, (zinc, copper, bronze) may also attack the elements. Dust from metal oxides in the furnace atmosphere reacts with the glaze. It is also important that the elements are protected from splashes of molten metal. Any metal or alloy with a melting point lower than approximately 1300 °C

(2370 °F) may be melted in a KANTHAL SUPER furnace if necessary precautions are taken. In small crucible furnaces where the elements are protected from metal fumes approx. 1550 °C (2820 °F) is possible.

Alkali

Compounds such as K_2O and Na_2O in the furnace atmosphere will act as a fluxing agent on the silica layer and attack the elements. Their salts also attack elements which may occur in glass melting furnaces.

The choice of lining material for furnaces operating at temperatures above 1550-1600 °C (2820-2910 °F) in particular is very important. Castables always contain alkalis. Due to how these are chemically bound in the castable they could be more or less aggressive to the KANTHAL SUPER elements.

Avoid castables containing alkali above 1550-1600 °C (2820-2910 °F) furnace temperature.

Ceramics

As the operating temperature of KANTHAL SUPER elements is normally rather high, reactions can easily take place between the silica layer on the element surface and most salts and oxides. This is of particular importance when the elements are supported by ceramics. The ceramics in these cases must consist of stable compounds, silicates, which do not react with silica. Suitable ceramics are **sillimanite** and **mullite**. At element temperatures exceeding 1600 °C (2910 °F) reactions can nevertheless occur. This element temperature should not be exceeded when the element rests on a ceramic support.

Firing of ceramics

Green ceramics (before firing) contain binders or similar, which during firing fume off, developing residual products. These residual products must be removed in order to minimize the contamination of furnace atmosphere and walls. At higher element temperatures, these residual products may attack the elements.

Glass

The atmosphere in a glass furnace normally has a slightly fluxing effect on the silica layer, thus lowering the viscosity and causing the glaze to flow slowly down the element. However, this normally has no detrimental effect on the life of the element.

3

Terminal shapes:

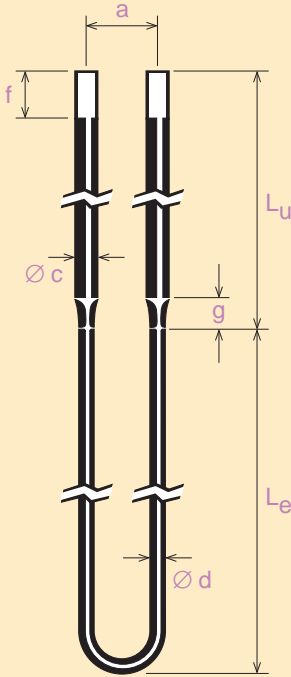

Fig. 6 Straight terminals.

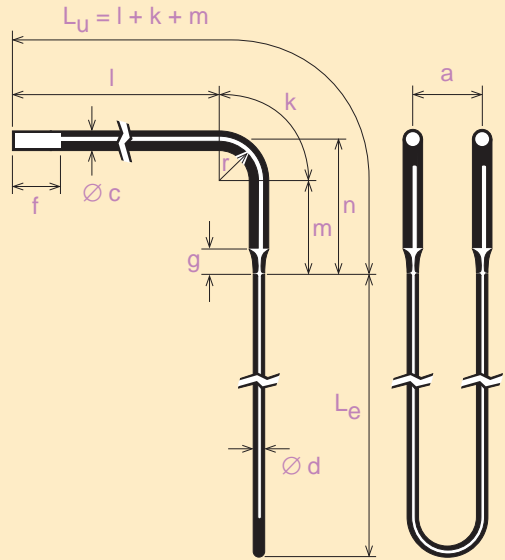

Fig. 7 Element bent 90° at the terminals.

The following parameters are valid for all KANTHAL SUPER elements.

Dimensional tolerances $\pm 5\%$ (except c and d).

Element size	a mm		c mm	d mm	f mm	g mm	k _{90°} mm	k _{45°} mm	m mm	n mm		r mm	
	Standard	Minimum								Standard	Minimum	Standard	Minimum
3/6	25	20	6	3	25	15	19	9	30	42	37	12	
4/9	25	20	9	4	25	15	19	9	35	47	37	12	
6/12	50	25	12	6	45	25	47	24	60	90	80	30	20
9/18	60	40	18	9	75	30	71	35	90	135	110	45	30
12/24	80	50	24	12	100	40							
Element size	a in.		c in.	d in.	f in.	g in.	k _{90°} in.	k _{45°} in.	m in.	n in.		r in.	
	Standard	Minimum								Standard	Minimum	Standard	Minimum
3/6	1.0	0.79	0.24	0.12	1.0	0.6	0.75	0.35	1.18	1.65	1.44	0.47	
4/9	1.0	0.79	0.35	0.16	1.0	0.6	0.75	0.35	1.38	1.85	1.44	0.47	
6/12	1.97	1.0	0.47	0.24	1.8	1	1.85	0.94	2.36	3.55	3.15	1.18	0.79
9/18	2.36	1.57	0.71	0.35	3.0	1.2	2.8	1.38	3.71	5.31	4.33	1.77	1.18
12/24	3.15	1.97	0.95	0.47	4.0	1.6							

Table 4 Parameters of KANTHAL SUPER Elements.

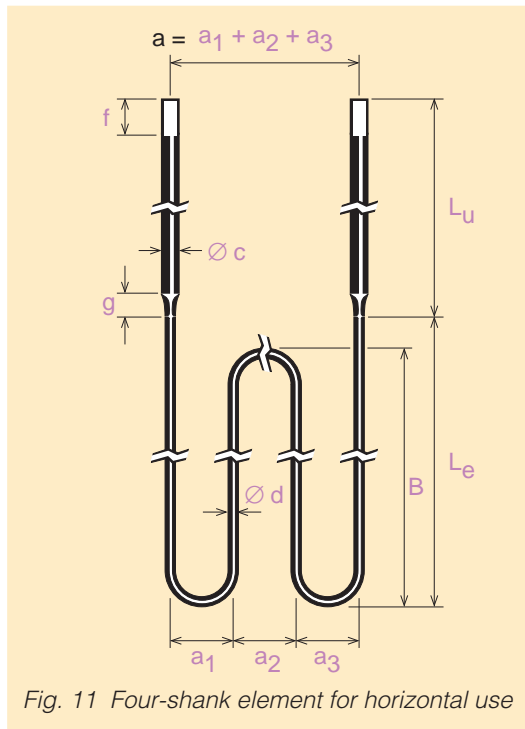
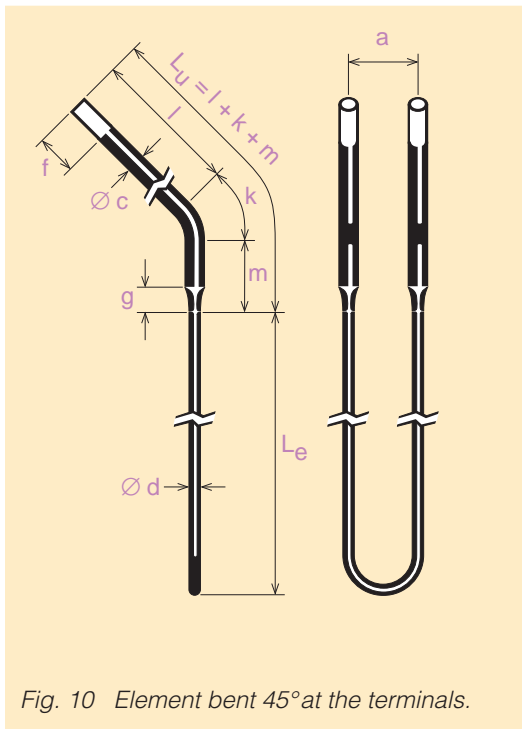
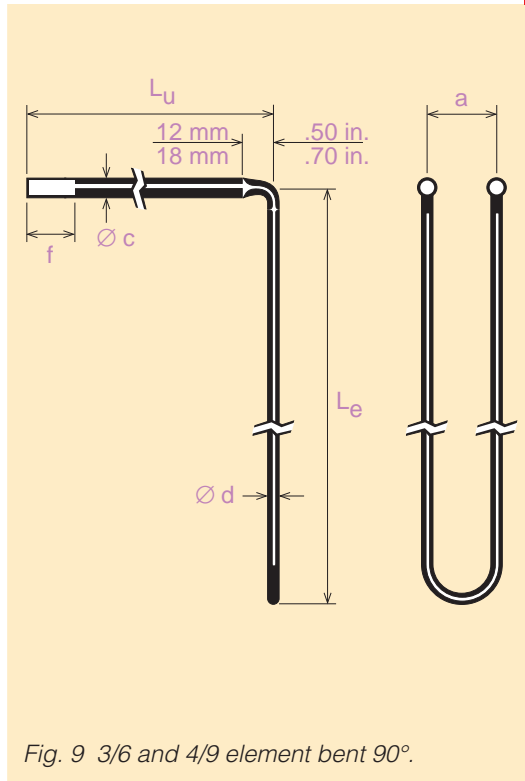
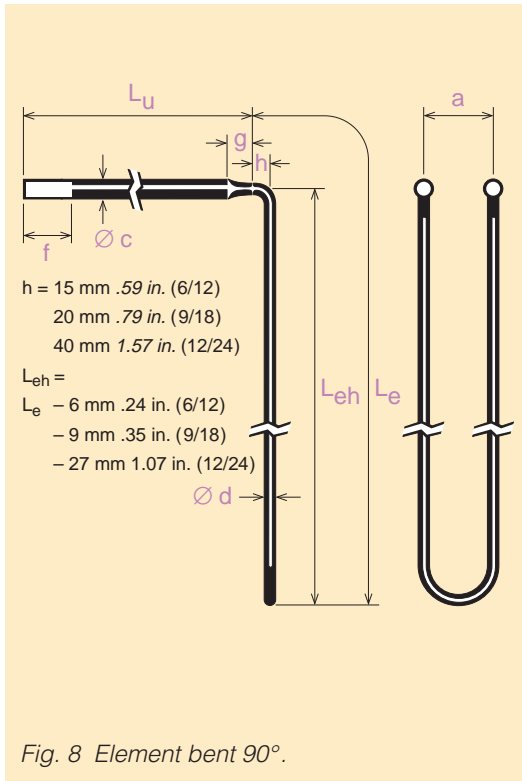

3

Two-shank bent elements

Bent elements are used when the electrical connections for some reason cannot be made above the roof. When the furnace is too high to permit installation of elements suspended from the roof, due to the limitation regarding the maximum permitted heating zone length, it may also be necessary to install elements with bent terminals or heating zones. By installing several rows of such elements it is also possible to control the power at different levels in the furnace.

The terminals are supported by brick or fibre, which normally limits the maximum temperature to 1600 °C (2910 °F) furnace temperature.

Four-shank 1700 elements for horizontal use

In many cases, particularly in furnaces with a low chamber height, the best choice is horizontally mounted elements.

The advantage of this shape is that fewer elements are needed than in the case of two-shank elements, with lower terminal losses, making the four-shank elements more economical. Maximum element temperature 1600 °C (2910 °F). Available as 6/12, 9/18 and 12/24 elements.

Four-shank elements with straight terminals (Fig. 11, page 19) are defined by:

- The quality
- Heating zone diameter, mm
- Terminal diameter, mm
- Terminal length, L_u , mm (in.)
- Heating zone length, L_e , mm (in.)
- Heating zone length, B , mm (in.)
- Centre distances between shanks, a , mm (in.)

Example: KANTHAL SUPER 1700 9/18

L_u = 450 (17.7 in.),

L_e = 450 (17.7 in.),

B = 400 (15.8 in.),

a = 3 x 60 (3 x 2.36 in.)

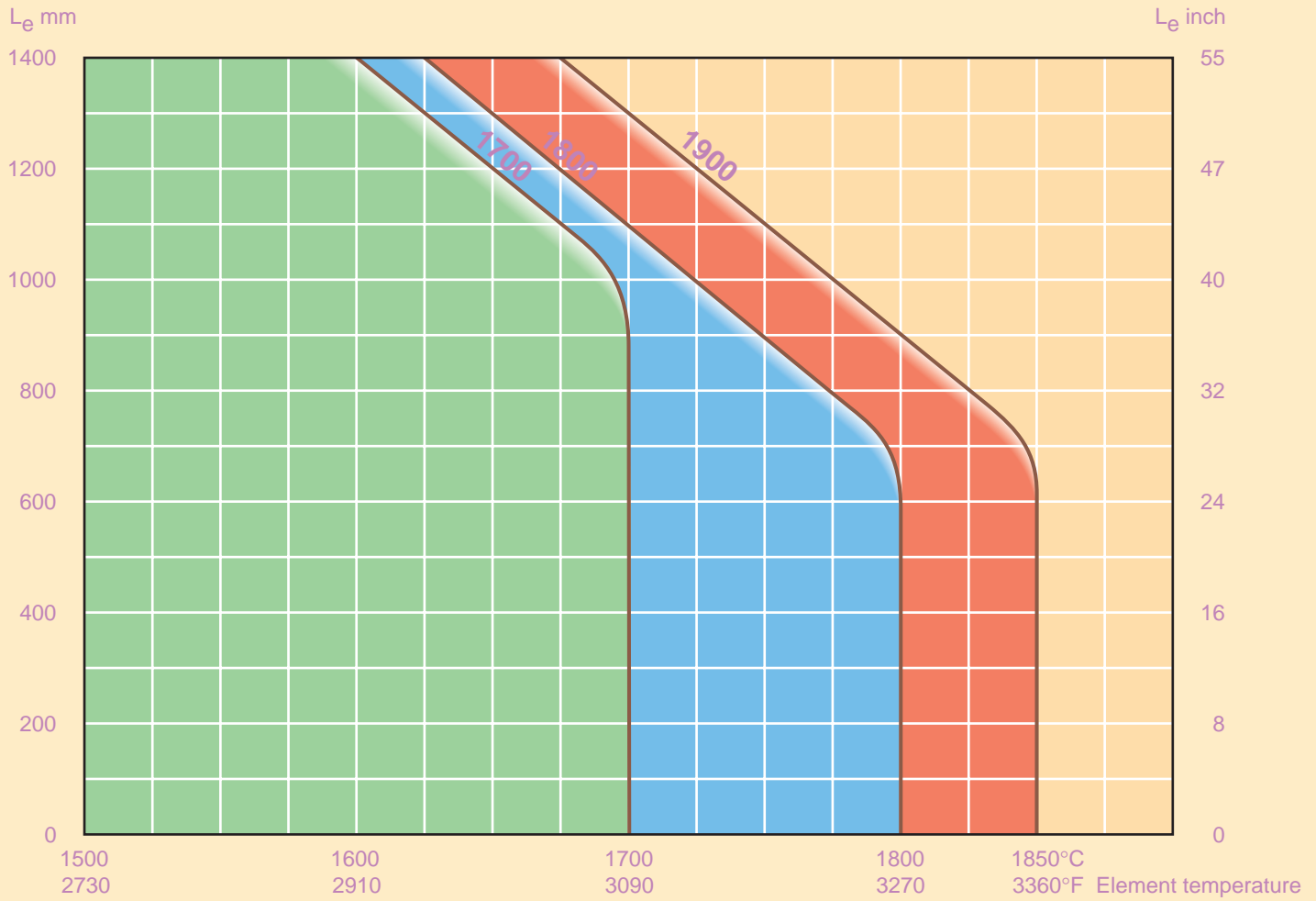

Fig.12 Maximum recommended heating zone lengths for vertically suspended 6/12, 9/18 and 12/24 mm elements.

3

Tubes

Tubes are normally manufactured in a quality corresponding to KANTHAL Super 1700. As the same material is used in the tubes as in the elements the data regarding properties previously given in the handbook is also valid for tubes. Standard sizes are manufactured as per table 5 page 23.

Maximum lengths

- For outer diameter = 7– 25 mm maximum 2000 mm.
- For outer diameter = 32 and 50 mm maximum 1000 mm.

Super bubble tubes

The standard Super bubbler tube has an ID of 3 mm and OD 12 mm – fig 14. Some glass works inquire smaller end holes for generation of smaller air bubbles.

Kanthal can now supply 12/3 tubes with a 5 mm welded endcap, in which we are able to make min 0,7 mm hole by water jet.

Examples of applications for KANTHAL SUPER tubes are:

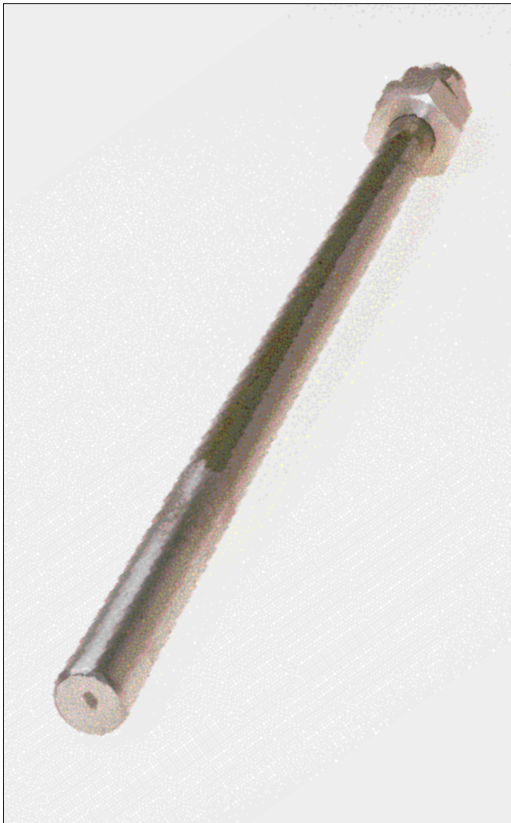

Fig. 13 Protection tubes for thermocouples.

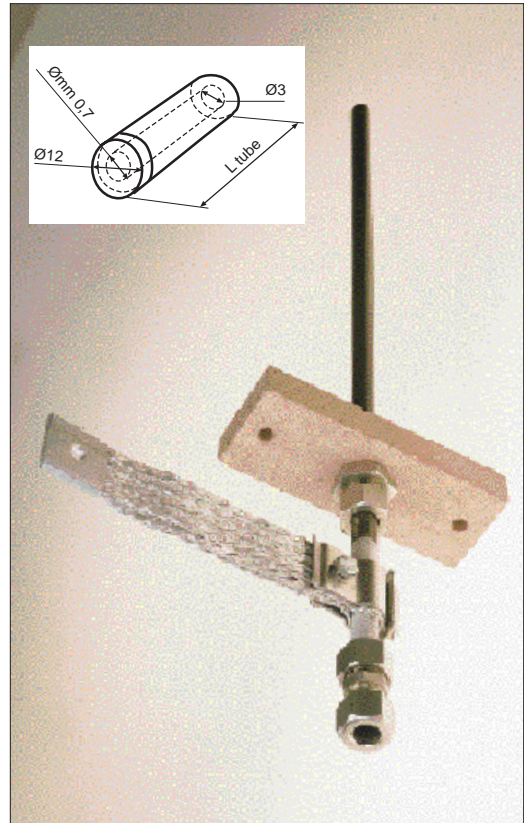

Fig. 14 Bubbler tubes for glass melting.

Standard tube sizes

Outside diameter ± 5%	mm	7	10	12	12	18	22	25	32	50
	in.	.28	.39	.47	.47	.71	.87	.98	1.26	1.97
Inside diameter ± 5%	mm	3	6	3	6	10	13	15	18	28
	in.	.12	.24	.12	.24	.39	.51	.59	.71	1.10

Table 5 KANTHAL SUPER tube diameters.

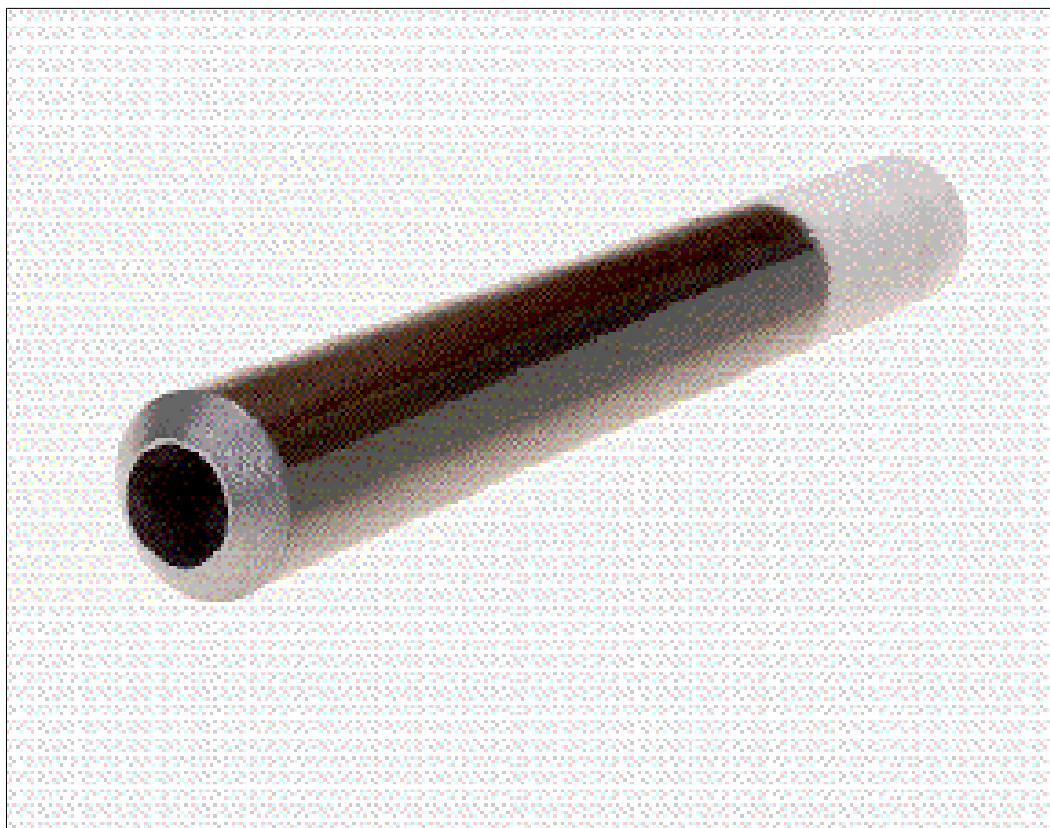
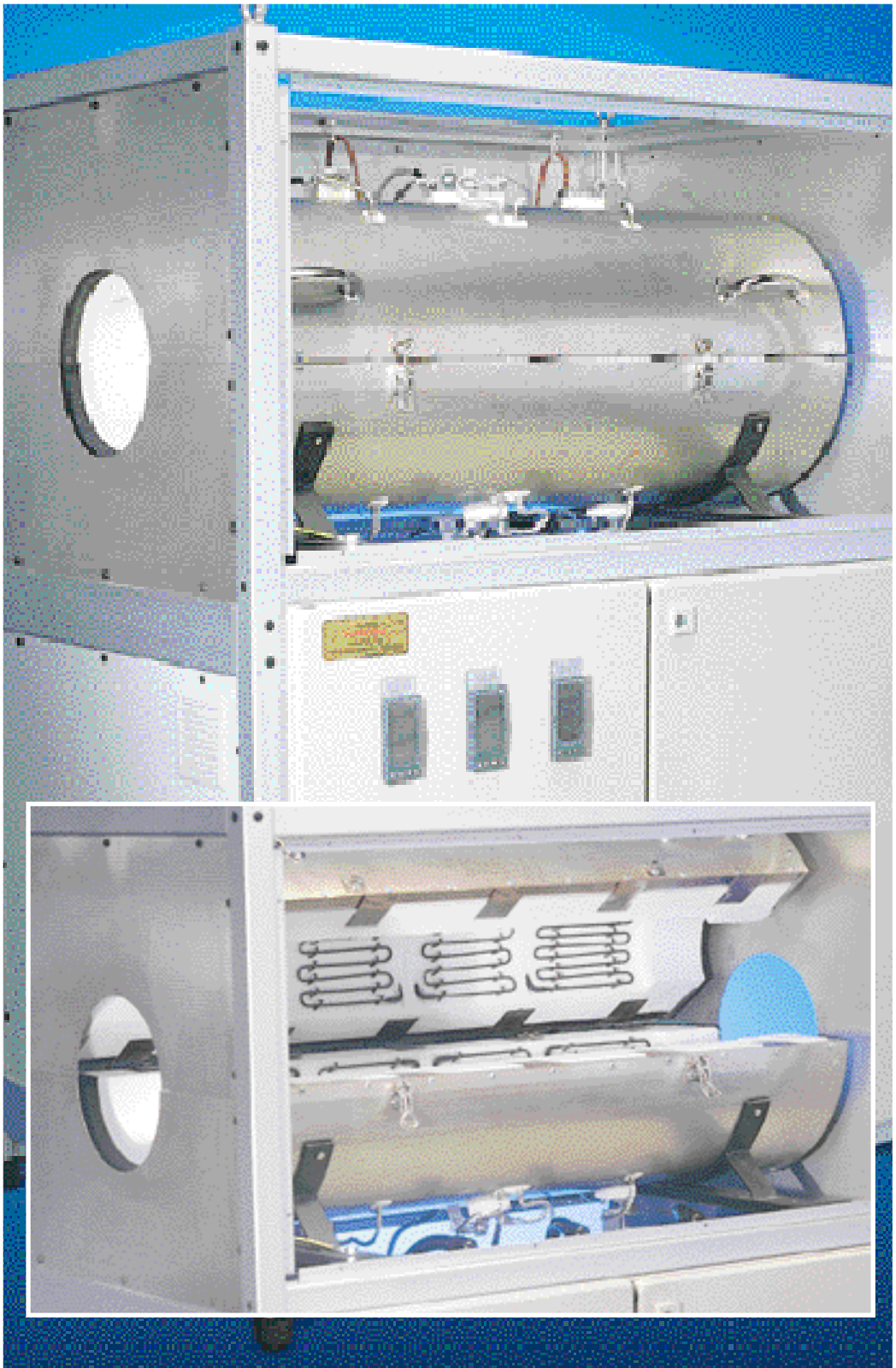

Fig. 15 Tubes for electrodes for glass melting.

Fig. 16 SUPERTHAL multi-zone tube furnace.



SUPERTHAL Heating Modules

The heating modules consist of vacuum formed ceramic fibre shapes, with an integral KANTHAL SUPER heating element.

The standard range includes muffles (SMU) and half cylinders (SHC). These can be readily adapted for use in test equipment and production units where compactness, rapid heating and accurate temperature profiles are needed.

The heating element in the standard modules is made from 3/6 mm KANTHAL SUPER 1800 material. The modules are capable of operating continuously in air up to a maximum of 1600 °C (2910 °F), element temperature.

The SUPERTHAL modules can be delivered as heating packages complete with back-up insulation and stainless steel casing.

The table 6 on page 27 gives basic data for standard modules which are based on an element temperature of 1500 °C (2730 °F) with a ceramic tube (work piece) inside.

When the modules are to be used to operate in their highest temperature range around 1550 °C (2820 °F), a higher voltage may be needed than shown in the tables, in order to achieve a satisfactory heating-up time from room temperature. However it is essential that the element temperature is not allowed to exceed 1600 °C (2910 °F) at any time during the heating cycle.

Naturally the SUPERTHAL modules are used at work-piece temperatures other than 1400 °C (2550 °F), and at different power levels where the element temperature will be lower than 1600 °C (2910 °F). For re-calculating the element data to suit the new requirements, the temperature — loading diagram Fig.17 page 28 is used.

The potential risk of over-heating the elements is even more pronounced when utilizing the SUPERTHAL modules for their high power capability at lower process temperatures, especially in very fast ramping situations, when SUPERTHAL can be considered as a highly powered infrared radiator rather than a conventional furnace heating system.

The IR energy from the KANTHAL SUPER heating element, emitted at a peak wavelength of about 1.5 µm, is absorbed by the ceramic fibre insulation and re-emitted at a longer wavelength. The effective energy transfer to the work piece is highly dependent on its geometry and the absorptive properties of the material, combined with the element (emitter) temperature.

Control of the heating rate is attained by varying the element temperature. Accurate control of the element temperature is critical in radiant heat transfer, as any fluctuation in the element temperature will be amplified in the heating rate by the fourth power function according to the heating equation. See Appendix 2 page 159.

The work-piece temperature also influences the heating rate. Therefore as the temperature of the work piece increases towards the element temperature, the effective heat transfer decreases at a constant element temperature.

Different materials also exhibit different emissivity values at the same temperature. Table 11 on page 159 in Appendix 2, lists some emissivity values of various materials with varying surface conditions.

4

Examples of calculations

Element data: SUPERTHAL SHC 200 H

$$P_{e\text{ tab}} = 1870 \text{ W} \quad R_t = 1.06 \Omega \quad T_e = 1500^\circ\text{C} (2730^\circ\text{F})$$

$$U_{e\text{ tab}} = 44.5 \text{ V} \quad I = 42 \text{ A} \quad \text{Max. work piece temperature is } 1400^\circ\text{C} (2550^\circ\text{F})$$

$$p_{\text{tab}} = 8.2 \text{ W/cm}^2 (53 \text{ W/in.}^2)$$

Alt. 1. The maximum power should be calculated.

At 1400°C (2550°F) according to the temperature - loading diagram Fig.17 on page 28, the maximum surface loading is 18 W/cm^2 (116 W/in.^2) at $T_e = 1600^\circ\text{C}$ (2910°F).

Maximum power is calculated:

$$P = P_e \times \frac{p}{p_{\text{tab}}} = 1870 \times \frac{18}{8.2} = 4105 \text{ W}$$

The resistance of KANTHAL SUPER 1800 is proportional to the element temperature according to the formula:

$$R_t = \frac{0.0028 \times T_e - 0.255}{d^2} \Omega/\text{m}; \left(R_t = \frac{(0.393 \times T_e - 71) \times 10^{-4}}{d^2} \Omega/\text{in.} (T_e \text{ in } ^\circ\text{F}, d \text{ in } \text{mm}) \right)$$

See also page 92.

R_t is calculated at $T_e = 1600^\circ\text{C}$ (2910°F)

$$R_t = \frac{0.0028 \times 1600 - 0.255}{0.0028 \times 1500 - 0.255} \times 1.06 = 1.14 \Omega \quad \left(R_t = \frac{0.393 \times 2910 - 71}{0.393 \times 2730 - 71} \times 1.06 = 1.14 \Omega \right)$$

$$\text{Voltage is calculated: } U = \sqrt{P \times R_t} = \sqrt{4105 \times 1.14} = 68.4 \text{ V}$$

$$\text{Current is calculated: } I = \frac{U}{R_t} = \frac{68.4}{1.14} = 60.0 \text{ A}$$

Alt. 2. The power needed is 1000 W.

The surface loading is calculated:

$$p = p_{\text{tab}} \times \frac{P}{P_{e\text{ tab}}} = 8.2 \times \frac{1000}{1870} = 4.4 \text{ W/cm}^2 (28 \text{ W/in.}^2)$$

According to the temperature — loading diagram Fig.17 page 28, the element temperature will be 1455°C (2650°F)

R_t is calculated according to the formula above at $T_e = 1455^\circ\text{C}$ (2650°F)

$$R_t = \frac{0.0028 \times 1455 - 0.255}{0.0028 \times 1500 - 0.255} \times 1.06 = 1.03 \Omega \quad \left(R_t = \frac{0.393 \times 2650 - 71}{0.393 \times 2730 - 71} \times 1.06 = 1.03 \Omega \right)$$

$$\text{Voltage is calculated: } U = \sqrt{P \times R_t} = \sqrt{1000 \times 1.03} = 32.1 \text{ V}$$

$$\text{Current is calculated: } I = \frac{U}{R_t} = \frac{32.1}{1.03} = 31.2 \text{ A}$$

Examples demonstrating SUPERTHAL's high power capabilities and the effect of the emissivity of the work piece

One module type SMU 150 A ($P_{e\text{ tab}} = 5050 \text{ W}$) was used to heat a water-cooled iron tube of $\varnothing 75 \text{ mm}$ (3 in.). A black colored coating was applied to the surface of the tube and the voltage was adjusted to attain an element temperature of 1600°C (2910°F).

The voltage, current, and power was measured and recorded as follows:

$$\text{Voltage: } 220 \text{ V} \quad \text{Current: } 69 \text{ A} \quad \text{Power: } 15\,200 \text{ W}$$

An identical tube was painted with aluminium paint, the voltage was then readjusted to achieve the 1600°C (2910°F) element temperature.

SUPERTHAL SMU and SHC 3/6 - standard modules

	SMU	SHC	
Element length, L_E	209 mm, option A	150 mm	
Overall length, L_T	250 mm	200 mm	
Data at element temperature		1500 °C (2730 °F)	Surface loading 8.2 W/cm ² (53 W/in. ²)
Furnace (work-piece) temperature		1400 °C (2550 °F)	Current 42 A
Max. continuous current 75 A			

Type	Inner dia mm (D_i)	Outer dia mm (D_o)	Resistance Ω	Voltage V	Power W
SMU 40 A	40	240	0.82	34.4	1445
SMU 60 A	60	260	1.19	50.0	2100
SMU 80 A	80	280	1.56	65.6	2760
SMU 100 A	90	300	1.94	81.3	3410
SMU 125 A	115	325	2.40	101	4230
SMU 150 A	140	350	2.86	120	5050
SMU 200 A	190	400	3.80	159	6690
SHC 100 H,V	85	300	0.57	23.9	1000
SHC 150 H,V	135	350	0.85	35.5	1490
SHC 200 H,V	185	400	1.12	47.1	1980
SHC 250 H,V	235	450	1.40	58.6	2460
SHC 300 H,V	285	500	1.67	70.2	2950

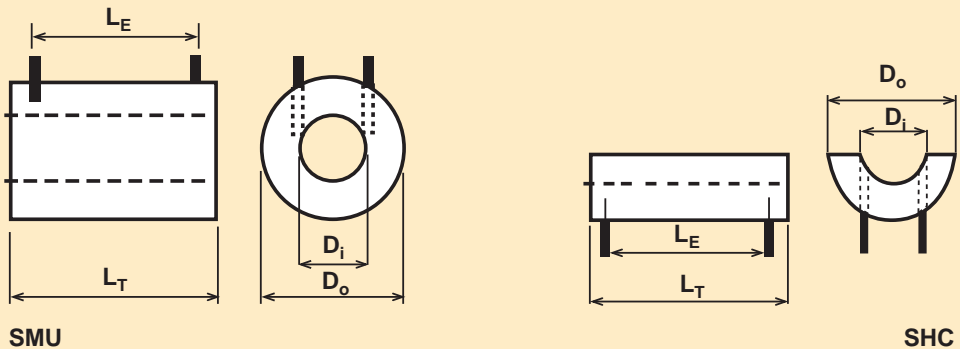

Table 6.

4

The voltage, current, and power was measured and recorded as follows:

Voltage: 178.5 V Current: 56 A Power: 10 000 W

These tests indicate that the emissivity of the work piece has to be considered in addition to it's thermal mass.

Please consult KANTHAL for advice regarding lower temperature processes which may require very high power utilization.

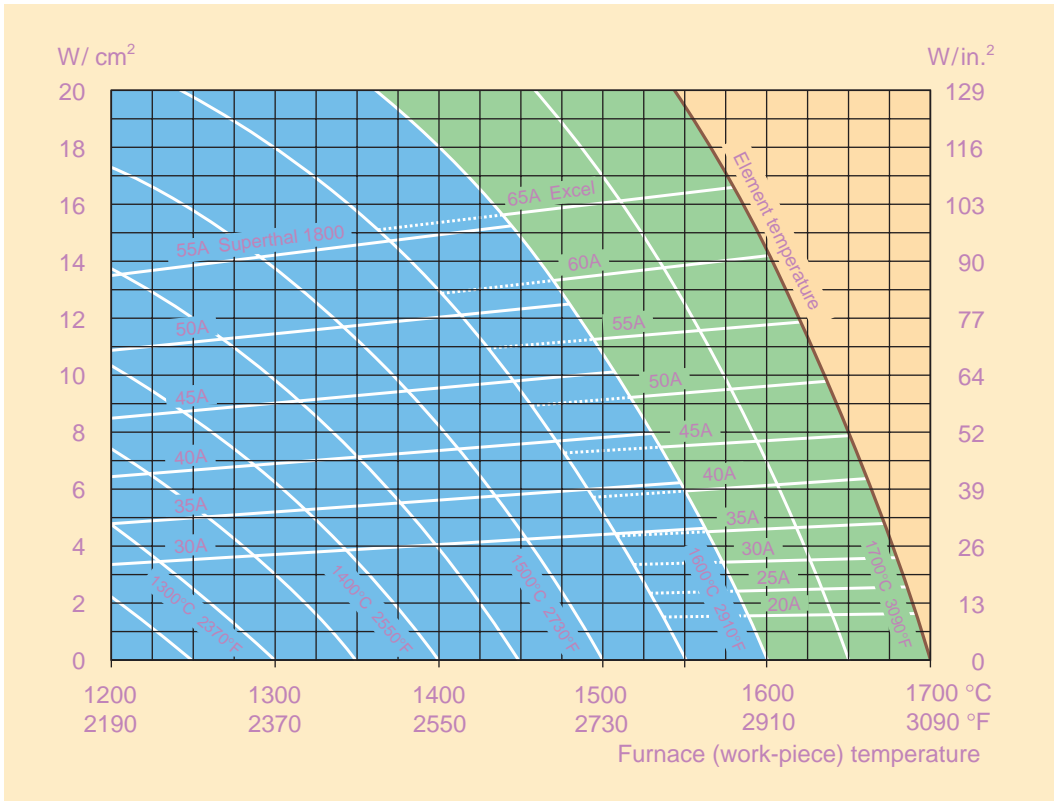

Fig. 17 Temperature — loading diagram for SUPERTHAL.



Fig. 18 SUPERTHAL SMU.



Fig. 19 SUPERTHAL SHC.

Option A is standard.

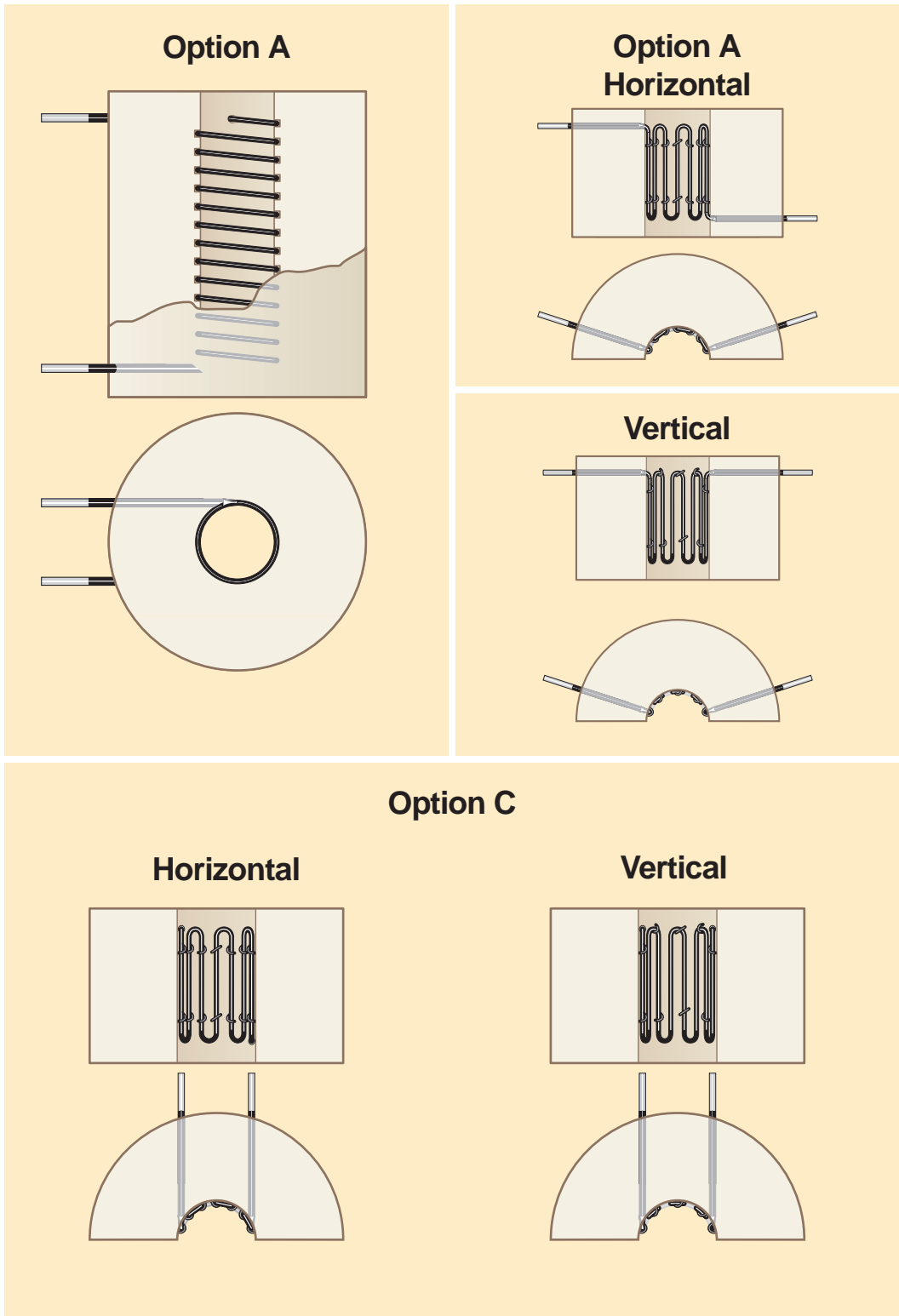

Fig. 20 SUPERHAL terminal designs.

4

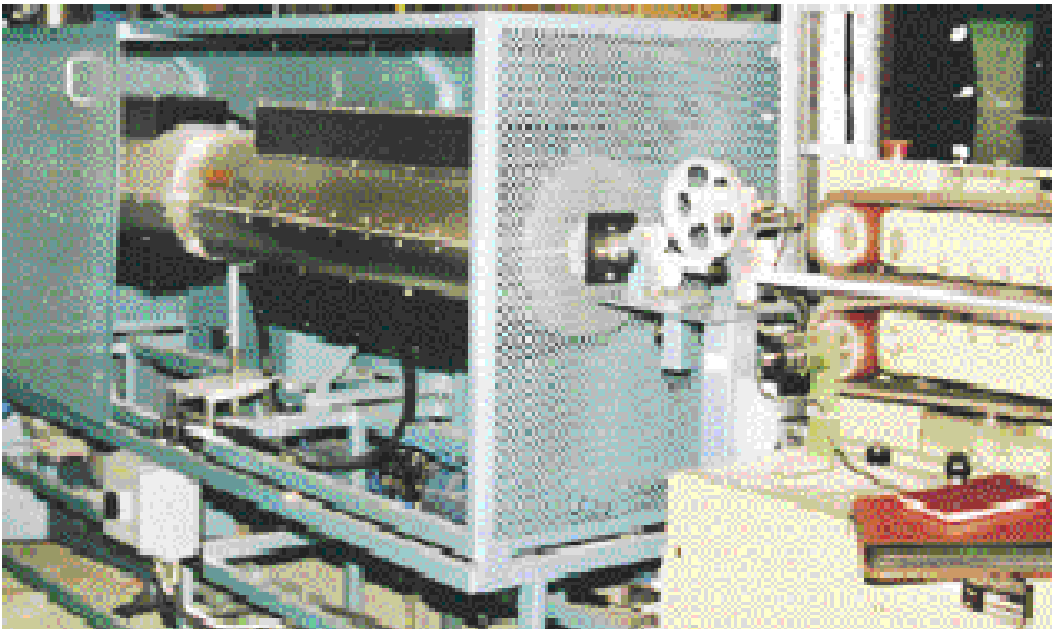
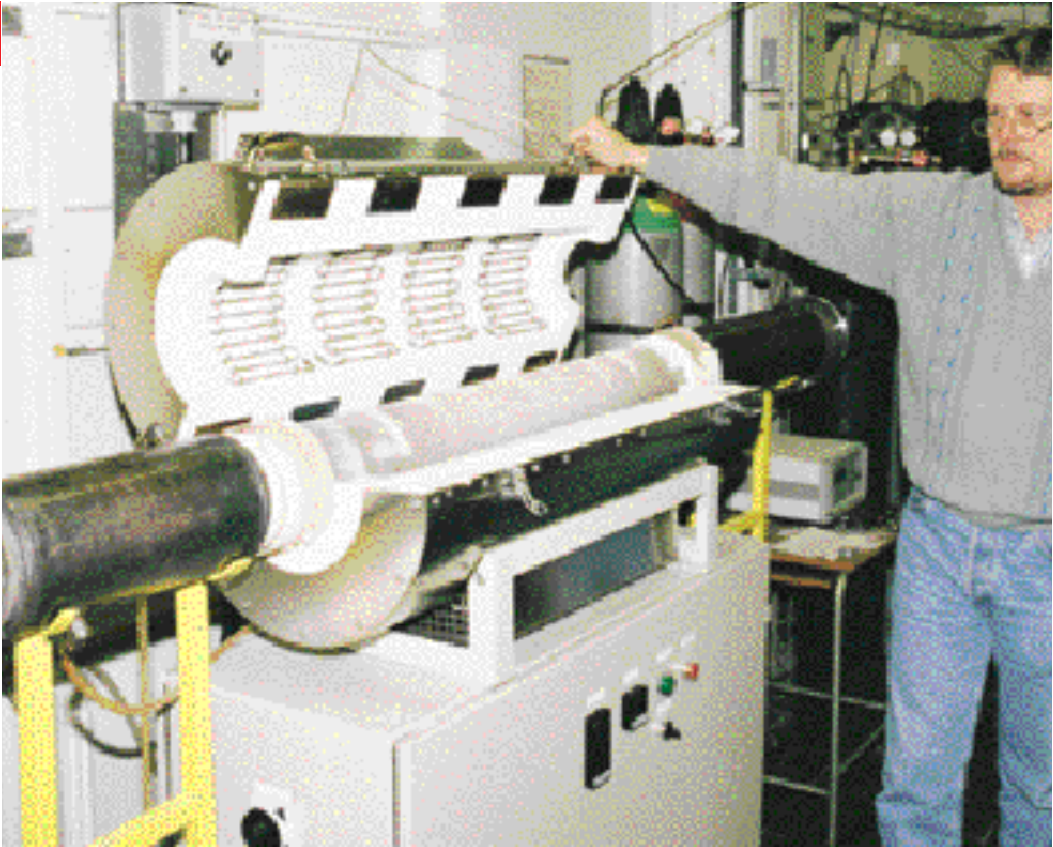

Fig. 21 SUPERthal tube furnace for materials testing and as IR-heater at plastic pipe manufacturing

Non standard SUPERTHAL modules

Special elements for muffles, half cylinders, and flat panels with 2, 3, 4, 6, 9, and 12 mm material can also be manufactured.

SUPERTHAL Flat Panels (SFP)

Multi shank elements are fitted to flat ceramic fibre panels for horizontal installation.

They are capable of operating continuously up to a maximum of 1600 °C (2900 °F) element temperature, in air. Typical applications include glass feeders, continuous sintering furnaces and continuous case hardening of steel.

SUPERTHAL Single Wafer Reactors (SWR)

Multi shank and flat coil elements are fitted to circular flat ceramic fibre panels for horizontal or vertical installation. The power is controlled radially, in order to attain even temperature.

They are capable of operating continuously up to a maximum of 1600 °C (2900 °F) element temperature, in air. Typical application is development of prototypes and processing of Silicon Wafers, where accurate temperature profiles, fast heat-up/cooling cycles, and high temperature capabilities are desirable parameters.

SUPERTHAL Infrared Radiators (SIR)

Multi shank elements of 3 or 4 mm KANTHAL SUPER 1800 material mounted in ceramic fibre boxes, freely radiating, are mainly used for drying purposes. The element temperature is in the range of 1550 °C (2820 °F), corresponding to a peak energy wavelength of about 1.5 μm . The inner surface of the ceramic fibre box normally has a temperature of 1100 °C (2010 °F), corresponding to a peak energy wavelength of about 2.2 μm . The maximum power concentration is about 240 kW/m².

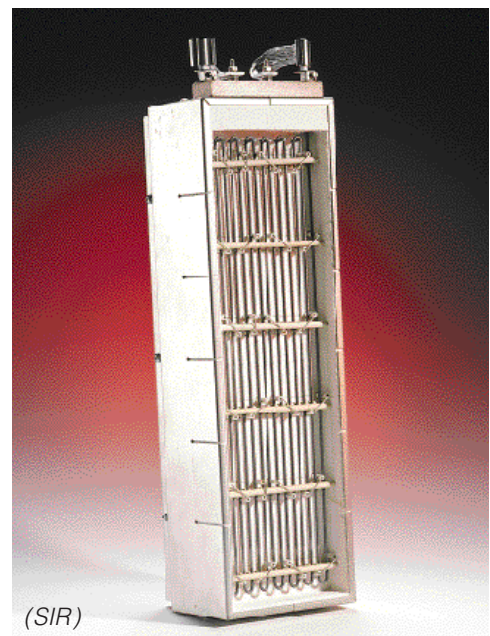
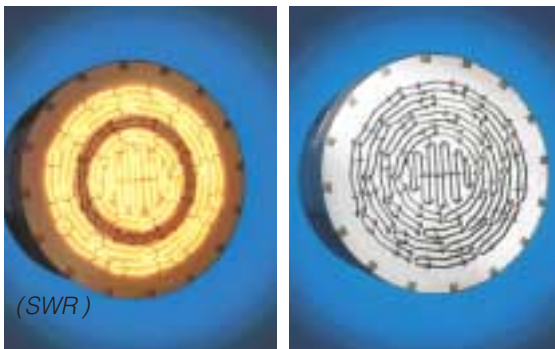

Fig. 22 SUPERTHAL high temperature material testing furnace.

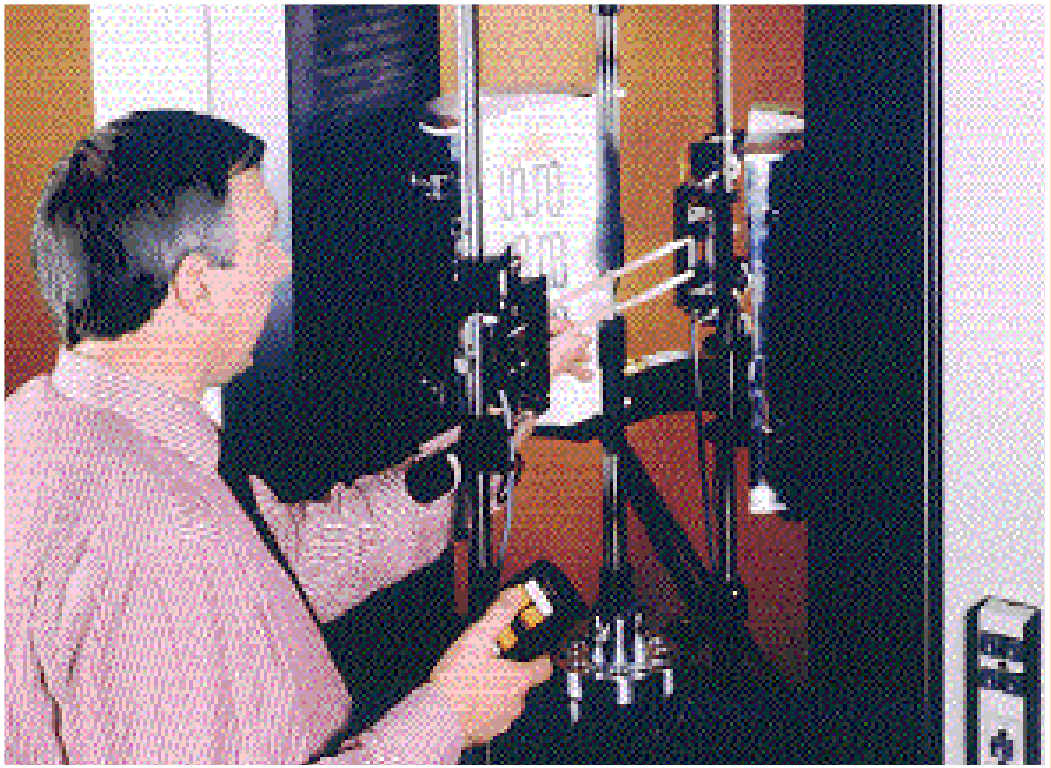
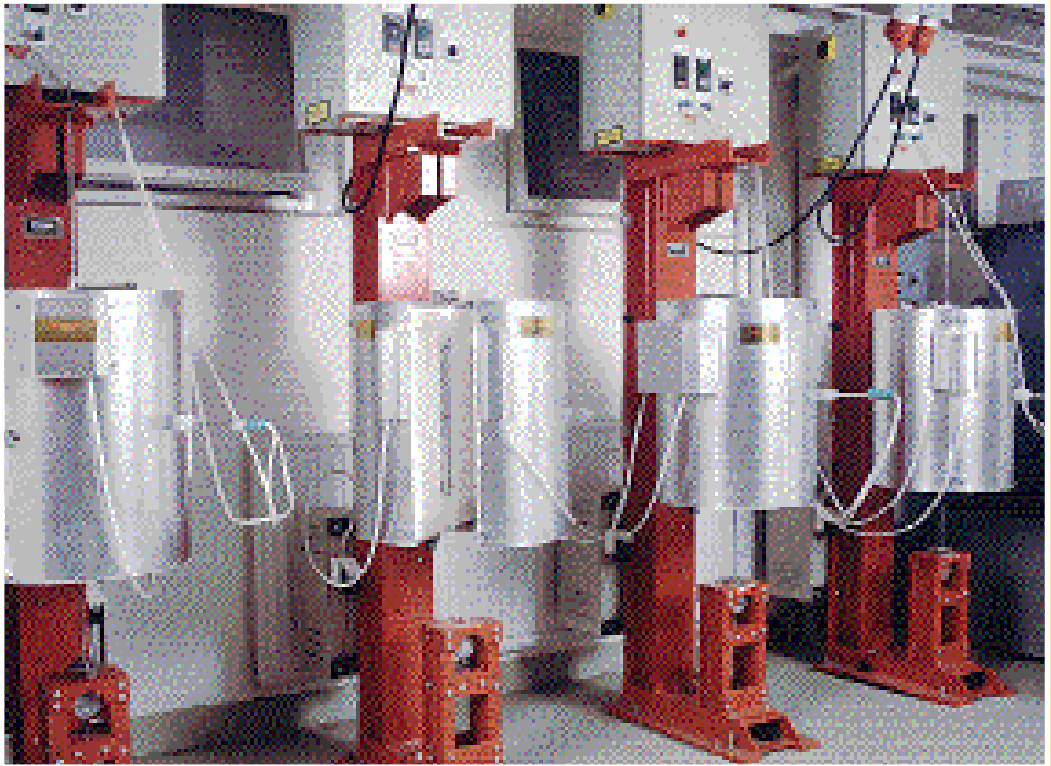

Fig. 23 SUPERTHAL creep testing furnaces.



Electrical data

	Page
Two-shank KANTHAL SUPER 1700 6/12	34
Four-shank KANTHAL SUPER 1700 6/12	36
Two-shank KANTHAL SUPER 1700 9/18	38
Four-shank KANTHAL SUPER 1700 9/18	40
Four-shank KANTHAL Super 1700 12/24	41
Two-shank KANTHAL SUPER 1700 12/24	42
Two-shank KANTHAL SUPER 1800 3/6	44
Two-shank KANTHAL SUPER 1800 4/9	46
Two-shank KANTHAL SUPER 1800 6/12	48
Two-shank KANTHAL SUPER 1800 9/18	50
Two-shank KANTHAL SUPER 1800 12/24	52
Two-shank KANTHAL SUPER 1900 3/6	54
Two-shank KANTHAL SUPER 1900 4/9	56
Two-shank KANTHAL SUPER 1900 6/12	58
Two-shank KANTHAL SUPER 1900 9/18	60

Two-Shank KANTHAL SUPER 1700 6/12

Power W
Resistance Ω
Volt V

Max. element temperature 1700 °C (3090 °F) Heating zone \varnothing mm 6 Furnace temp. °C 1300 (2370° F) Element current A 166
Terminal \varnothing mm 12 Element temp. °C 1550 (2820° F) Surface loading W/cm² 16.6
Shank distance mm 50 W/in.² 107

Heating zone, L_e mm →

Terminal L_t mm ↓

	4.9 in. 125	6.3 in. 160	7.1 in. 180	7.9 in. 200	8.9 in. 225	9.8 in. 250	11 in. 280	12.4 in. 315	14 in. 355	15.8 in. 400	17.7 in. 450	19.7 in. 500	22 in. 560	24.8 in. 630	26.4 in. 670	28 in. 710	31.5 in. 800	35.4 in. 900	39.4 in. 1000	44.1 in. 1120	49.2 in. 1250	55.1 in. 1400
4.9 in. 125	1020 0.037 6.2	1240 0.045 7.5	1370 0.050 8.2	1490 0.054 9.0	1650 0.060 9.9	1810 0.066 10.9	1990 0.072 12.0	2210 0.080 13.3	2460 0.089 14.8	2740 0.100 16.5	3060 0.111 18.4	3370 0.122 20.3	3740 0.136 22.6	4180 0.152 25.2	4430 0.161 26.7	4680 0.170 28.2	5250 0.190 31.6	5870 0.213 35.4	6500 0.236 39.1	7250 0.263 43.7	8060 0.292 48.6	9000 0.327 54.2
5.5 in. 140	1040 0.038 6.2	1260 0.046 7.6	1380 0.050 8.3	1510 0.055 9.1	1660 0.060 10.0	1820 0.066 11.0	2010 0.073 12.1	2230 0.081 13.4	2480 0.090 14.9	2760 0.100 16.6	3070 0.111 18.5	3380 0.123 20.4	3760 0.136 22.6	4200 0.152 25.3	4450 0.161 26.8	4700 0.170 28.3	5260 0.191 31.7	5880 0.214 35.4	6510 0.236 39.2	7260 0.263 43.7	8070 0.293 48.6	9010 0.327 54.3
6.3 in. 160	1060 0.038 6.4	1270 0.046 7.7	1400 0.051 8.4	1520 0.055 9.2	1680 0.061 10.1	1840 0.067 11.1	2020 0.073 12.2	2240 0.081 13.5	2490 0.090 15.0	2770 0.101 16.7	3090 0.112 18.6	3400 0.123 20.5	3780 0.137 22.7	4210 0.153 25.4	4460 0.162 26.9	4710 0.171 28.4	5280 0.191 31.8	5900 0.214 35.6	6530 0.237 39.3	7280 0.264 43.8	8090 0.294 48.7	9030 0.328 54.4
7.1 in. 180	1070 0.039 6.5	1290 0.047 7.8	1420 0.051 8.5	1540 0.056 9.3	1700 0.062 10.2	1850 0.067 11.2	2040 0.074 12.3	2260 0.082 13.6	2510 0.091 15.1	2790 0.101 16.8	3110 0.113 18.7	3420 0.124 20.6	3790 0.138 22.8	4230 0.154 25.5	4480 0.163 27.0	4730 0.172 28.5	5290 0.192 31.9	5920 0.215 35.7	6540 0.237 39.4	7290 0.265 43.9	8110 0.294 48.8	9050 0.328 54.5
7.9 in. 200	1090 0.040 6.6	1310 0.048 7.9	1430 0.052 8.6	1560 0.057 9.4	1720 0.062 10.3	1870 0.068 11.3	2060 0.075 12.4	2280 0.083 13.7	2530 0.092 15.2	2810 0.102 16.9	3120 0.113 18.8	3440 0.125 20.7	3810 0.138 23.0	4250 0.154 25.6	4500 0.163 27.1	4750 0.172 28.6	5310 0.193 32.0	5940 0.215 35.8	6560 0.238 39.5	7310 0.265 44.1	8130 0.295 48.9	9060 0.329 54.6
8.9 in. 225	1110 0.040 6.7	1330 0.048 8.0	1460 0.053 8.8	1580 0.057 9.5	1740 0.063 10.5	1890 0.069 11.4	2080 0.076 12.5	2300 0.083 13.9	2550 0.093 15.4	2830 0.103 17.1	3140 0.114 18.9	3460 0.125 20.8	3830 0.139 23.1	4270 0.155 25.7	4520 0.164 27.2	4770 0.173 28.7	5330 0.194 32.1	5960 0.216 35.9	6580 0.239 39.7	7330 0.266 44.2	8150 0.296 49.1	9090 0.330 54.7
9.8 in. 250	1130 0.041 6.8	1350 0.049 8.1	1480 0.054 8.9	1600 0.058 9.7	1760 0.064 10.6	1920 0.070 11.5	2100 0.076 12.7	2320 0.084 14.0	2570 0.093 15.5	2850 0.104 17.2	3170 0.115 19.1	3480 0.126 21.0	3850 0.140 23.2	4290 0.156 25.9	4540 0.165 27.4	4790 0.174 28.9	5360 0.194 32.3	5980 0.217 36.0	6610 0.240 39.8	7360 0.267 44.3	8170 0.296 49.2	9110 0.331 54.9
11 in. 280	1160 0.042 7.0	1380 0.050 8.3	1500 0.055 9.1	1630 0.059 9.8	1790 0.065 10.8	1940 0.070 11.7	2130 0.077 12.8	2350 0.085 14.1	2600 0.094 15.7	2880 0.105 17.3	3190 0.116 19.2	3510 0.127 21.1	3880 0.141 23.4	4320 0.157 26.0	4570 0.166 27.5	4820 0.175 29.0	5380 0.195 32.4	6010 0.218 36.2	6630 0.241 40.0	7380 0.268 44.5	8200 0.297 49.4	9130 0.331 55.0
12.4 in. 315	1190 0.043 7.2	1410 0.051 8.5	1530 0.056 9.2	1660 0.060 10.0	1820 0.066 10.9	1970 0.072 11.9	2160 0.078 13.0	2380 0.086 14.3	2630 0.095 15.8	2910 0.106 17.5	3220 0.117 19.4	3540 0.128 21.3	3910 0.142 23.6	4350 0.158 26.2	4600 0.167 27.7	4850 0.176 29.2	5410 0.196 32.6	6040 0.219 36.4	6660 0.242 40.1	7410 0.269 44.7	8230 0.299 49.6	9160 0.333 55.2
14 in. 355	1230 0.044 7.4	1450 0.052 8.7	1570 0.057 9.5	1700 0.062 10.2	1850 0.067 11.2	2010 0.073 12.1	2200 0.080 13.2	2410 0.088 14.5	2660 0.097 16.1	2950 0.107 17.7	3260 0.118 19.6	3570 0.130 21.5	3950 0.143 23.8	4380 0.159 26.4	4630 0.168 27.9	4880 0.177 29.4	5450 0.198 32.8	6070 0.220 36.6	6700 0.243 40.4	7450 0.270 44.9	8260 0.300 49.8	9200 0.334 55.4
15.8 in. 400	1270 0.046 7.6	1480 0.054 8.9	1610 0.058 9.7	1730 0.063 10.4	1890 0.069 11.4	2050 0.074 12.3	2230 0.081 13.5	2450 0.089 14.8	2700 0.098 16.3	2990 0.108 18.0	3300 0.120 19.9	3610 0.131 21.8	3990 0.145 24.0	4420 0.161 26.6	4670 0.170 28.2	4920 0.179 29.7	5490 0.199 33.1	6110 0.222 36.8	6740 0.245 40.6	7490 0.272 45.1	8300 0.301 50.0	9240 0.335 55.7
17.7 in. 450	1310 0.048 7.9	1530 0.055 9.2	1650 0.060 10.0	1780 0.065 10.7	1930 0.070 11.7	2090 0.076 12.6	2280 0.083 13.7	2500 0.091 15.0	2750 0.100 16.6	3030 0.110 18.2	3340 0.121 20.1	3650 0.133 22.0	4030 0.146 24.3	4470 0.162 26.9	4720 0.171 28.4	4970 0.180 29.9	5530 0.201 33.3	6160 0.223 37.1	6780 0.246 40.9	7530 0.273 45.4	8340 0.303 50.3	9280 0.337 55.9
19.7 in. 500	1350 0.049 8.2	1570 0.057 9.5	1700 0.062 10.2	1820 0.066 11.0	1980 0.072 11.9	2140 0.077 12.9	2320 0.084 14.0	2540 0.092 15.3	2790 0.101 16.8	3070 0.112 18.5	3390 0.123 20.4	3700 0.134 22.3	4070 0.148 24.5	4510 0.164 27.2	4760 0.173 28.7	5010 0.182 30.2	5570 0.202 33.6	6200 0.225 37.3	6830 0.248 41.1	7580 0.275 45.6	8390 0.304 50.5	9330 0.338 56.2
22 in. 560	1410 0.051 8.5	1620 0.059 9.8	1750 0.064 10.5	1880 0.068 11.3	2030 0.074 12.2	2190 0.079 13.2	2380 0.086 14.3	2590 0.094 15.6	2840 0.103 17.1	3130 0.113 18.8	3440 0.125 20.7	3750 0.136 22.6	4130 0.150 24.9	4560 0.166 27.5	4810 0.175 29.0	5060 0.184 30.5	5630 0.204 33.9	6250 0.227 37.7	6880 0.250 41.4	7630 0.277 46.0	8440 0.306 50.9	9380 0.340 56.5
24.8 in. 630	1470 0.053 8.8	1690 0.061 10.2	1810 0.066 10.9	1940 0.070 11.7	2090 0.076 12.6	2250 0.082 13.5	2440 0.088 14.7	2660 0.096 16.0	2910 0.105 17.5	3190 0.116 19.2	3500 0.127 21.1	3810 0.138 23.0	4190 0.152 25.2	4630 0.168 27.9	4880 0.177 29.4	5130 0.186 30.9	5690 0.206 34.3	6310 0.229 38.0	6940 0.252 41.8	7690 0.279 46.3	8500 0.309 51.2	9440 0.343 56.9
26.4 in. 670	1500 0.055 9.1	1720 0.062 10.4	1850 0.067 11.1	1970 0.072 11.9	2130 0.077 12.8	2280 0.083 13.8	2470 0.090 14.9	2690 0.098 16.2	2940 0.107 17.7	3220 0.117 19.4	3540 0.128 21.3	3850 0.140 23.2	4220 0.153 25.4	4660 0.169 28.1	4910 0.178 29.6	5160 0.187 31.1	5720 0.208 34.5	6350 0.230 38.2	6970 0.253 42.0	7720 0.280 46.5	8540 0.310 51.4	9480 0.344 57.1
28 in. 710	1540 0.056 9.3	1760 0.064 10.6	1880 0.068 11.3	2010 0.073 12.1	2160 0.078 13.0	2320 0.084 14.0	2510 0.091 15.1	2730 0.099 16.4	2980 0.108 17.9	3260 0.118 19.6	3570 0.130 21.5	3880 0.141 23.4	4260 0.155 25.7	4700 0.170 28.3	4950 0.179 29.8	5200 0.189 31.3	5760 0.209 34.7	6380 0.232 38.5	7010 0.254 42.2	7760 0.282 46.7	8570 0.311 51.6	9510 0.345 57.3
31.5 in. 800	1620 0.059 9.7	1840 0.067 11.1	1960 0.071 11.8	2090 0.076 12.6	2240 0.081 13.5	2400 0.087 14.4	2590 0.094 15.6	2800 0.102 16.9	3060 0.111 18.4	3340 0.121 20.1	3650 0.132 22.0	3960 0.144 23.9	4340 0.157 26.1	4770 0.173 28.8	5020 0.182 30.3	5280 0.191 31.8	5840 0.212 35.2	6460 0.235 38.9	7090 0.257 42.7	7840 0.284 47.2	8650 0.314 52.1	9590 0.348 57.8

Four-Shank KANTHAL SUPER 1700 6/12

Power W
Resistance Ω
Volt V

Max. element temperature 1700 °C (3090 °F) Heating zone \varnothing mm 6 Furnace temp. °C 1300 (2370° F) Element current A 166
Terminal \varnothing mm 12 Element temp. °C 1550 (2820° F) Surface loading W/cm² 16.6
Shank distance mm 50 W/in² 107

Heating zone, L_e mm \longrightarrow

	5.5 in. 140	7.9 in. 200	9.8 in. 250	11.4 in. 290	12.4 in. 315	14 in. 355	16.1 in. 410	17.7 in. 450	19.7 in. 500	24.4 in. 620	29.5 in. 750	
Terminal L_u mm \downarrow	15.8 in. 400	2380 0.086 14.3	3130 0.113 18.8	3750 0.136 22.6	4250 0.154 25.6	4560 0.166 27.5	5060 0.184 30.5	5750 0.209 34.7	6250 0.227 37.7	6880 0.250 41.4	8380 0.304 50.5	10010 0.363 60.3
	17.7 in. 450	2420 0.088 14.6	3170 0.115 19.1	3800 0.138 22.9	4300 0.156 25.9	4610 0.167 27.8	5110 0.185 30.8	5800 0.210 34.9	6300 0.229 37.9	6920 0.251 41.7	8420 0.306 50.7	10050 0.365 60.5
	18.5 in. 470	2440 0.088 14.7	3190 0.116 19.2	3810 0.138 23.0	4310 0.157 26.0	4630 0.168 27.9	5130 0.186 30.9	5810 0.211 35.0	6310 0.229 38.0	6940 0.252 41.8	8440 0.306 50.8	10070 0.365 60.6
	19.7 in. 500	2460 0.089 14.8	3210 0.117 19.4	3840 0.139 23.1	4340 0.157 26.1	4650 0.169 28.0	5150 0.187 31.0	5840 0.212 35.2	6340 0.230 38.2	6970 0.253 42.0	8470 0.307 51.0	10090 0.366 60.8
	20.5 in. 520	2480 0.090 14.9	3230 0.117 19.5	3860 0.140 23.2	4360 0.158 26.2	4670 0.169 28.1	5170 0.188 31.1	5860 0.213 35.3	6360 0.231 38.3	6980 0.253 42.1	8480 0.308 51.1	10110 0.367 60.9
	22 in. 560	2520 0.091 15.2	3270 0.119 19.7	3890 0.141 23.4	4390 0.159 26.5	4700 0.171 28.3	5210 0.189 31.4	5890 0.214 35.5	6390 0.232 38.5	7020 0.255 42.3	8520 0.309 51.3	10150 0.368 61.1
	23.6 in. 600	2550 0.093 15.4	3300 0.120 19.9	3930 0.143 23.7	4430 0.161 26.7	4740 0.172 28.6	5240 0.190 31.6	5930 0.215 35.7	6430 0.233 38.7	7050 0.256 42.5	8550 0.310 51.5	10180 0.369 61.3
	24.8 in. 630	2580 0.094 15.5	3330 0.121 20.0	3950 0.143 23.8	4450 0.162 26.8	4770 0.173 28.7	5270 0.191 31.7	5950 0.216 35.9	6450 0.234 38.9	7080 0.257 42.7	8580 0.311 51.7	10210 0.370 61.5
	28 in. 710	2650 0.096 16.0	3400 0.123 20.5	4020 0.146 24.2	4520 0.164 27.3	4840 0.176 29.1	5340 0.194 32.1	6020 0.219 36.3	6520 0.237 39.3	7150 0.259 43.1	8650 0.314 52.1	10280 0.373 61.9

Two-Shank KANTHAL SUPER 1700 9/18

Power W
Resistance Ω
Volt V

Max. element temperature 1700 °C (3090 °F) Heating zone \varnothing mm 9 Furnace temp. °C 1300 (2370° F) Element current A 305
Terminal \varnothing mm 18 Element temp. °C 1550 (2820° F) Surface loading W/cm² 16.6
Shank distance mm 60 W/in.² 107

Heating zone, L_e mm \longrightarrow

	4.9 in. 125	6.3 in. 160	7.1 in. 180	7.9 in. 200	8.9 in. 225	9.8 in. 250	11 in. 280	12.4 in. 315	14 in. 355	15.8 in. 400	17.7 in. 450	19.7 in. 500	22 in. 560	24.8 in. 630	26.4 in. 670	28 in. 710	31.5 in. 800	35.4 in. 900	39.4 in. 1000	44.1 in. 1120	49.2 in. 1250	55.1 in. 1400
11 in. 280	1750 0.019 5.7	2080 0.022 6.8	2270 0.024 7.4	2460 0.026 8.1	2690 0.029 8.8	2930 0.031 9.6	3210 0.034 10.5	3540 0.038 11.6	3910 0.042 12.8	4330 0.047 14.2	4800 0.052 15.7	5270 0.057 17.3	5840 0.063 19.1	6490 0.070 21.3	6870 0.074 22.5	7240 0.078 23.7	8090 0.087 26.5	9030 0.097 29.6	9960 0.107 32.7	11090 0.119 36.4	12310 0.132 40.4	13720 0.147 45.0
12.4 in. 315	1800 0.019 5.9	2130 0.023 7.0	2320 0.025 7.6	2500 0.027 8.2	2740 0.029 9.0	2970 0.032 9.7	3250 0.035 10.7	3580 0.039 11.7	3960 0.043 13.0	4380 0.047 14.4	4850 0.052 15.9	5320 0.057 17.4	5880 0.063 19.3	6540 0.070 21.4	6910 0.074 22.7	7290 0.078 23.9	8130 0.087 26.7	9070 0.098 29.7	10010 0.108 32.8	11140 0.120 36.5	12360 0.133 40.5	13760 0.148 45.1
14 in. 355	1850 0.020 6.1	2180 0.023 7.1	2370 0.025 7.8	2560 0.027 8.4	2790 0.030 9.1	3030 0.033 9.9	3310 0.036 10.8	3640 0.039 11.9	4010 0.043 13.1	4430 0.048 14.5	4900 0.053 16.1	5370 0.058 17.6	5930 0.064 19.5	6590 0.071 21.6	6970 0.075 22.8	7340 0.079 24.1	8190 0.088 26.8	9120 0.098 29.9	10060 0.108 33.0	11190 0.120 36.7	12410 0.133 40.7	13820 0.149 45.3
15.8 in. 400	1910 0.021 6.3	2240 0.024 7.3	2430 0.026 8.0	2620 0.028 8.6	2850 0.031 9.3	3080 0.033 10.1	3370 0.036 11.0	3690 0.040 12.1	4070 0.044 13.3	4490 0.048 14.7	4960 0.053 16.3	5430 0.058 17.8	5990 0.064 19.6	6650 0.071 21.8	7030 0.076 23.0	7400 0.080 24.3	8250 0.089 27.0	9180 0.099 30.1	10120 0.109 33.2	11250 0.121 36.9	12470 0.134 40.9	13870 0.149 45.5
17.7 in. 450	1980 0.021 6.5	2310 0.025 7.6	2490 0.027 8.2	2680 0.029 8.8	2920 0.031 9.6	3150 0.034 10.3	3430 0.037 11.3	3760 0.040 12.3	4140 0.044 13.6	4560 0.049 14.9	5030 0.054 16.5	5500 0.059 18.0	6060 0.065 19.9	6720 0.072 22.0	7090 0.076 23.2	7470 0.080 24.5	8310 0.089 27.2	9250 0.099 30.3	10190 0.110 33.4	11310 0.122 37.1	12530 0.135 41.1	13940 0.150 45.7
19.7 in. 500	2040 0.022 6.7	2370 0.025 7.8	2560 0.028 8.4	2750 0.030 9.0	2980 0.032 9.8	3220 0.035 10.5	3500 0.038 11.5	3830 0.041 12.5	4200 0.045 13.8	4620 0.050 15.2	5090 0.055 16.7	5560 0.060 18.2	6120 0.066 20.1	6780 0.073 22.2	7160 0.077 23.5	7530 0.081 24.7	8380 0.090 27.5	9320 0.100 30.5	10250 0.110 33.6	11380 0.122 37.3	12600 0.135 41.3	14010 0.151 45.9
22 in. 560	2120 0.023 7.0	2450 0.026 8.0	2640 0.028 8.7	2830 0.030 9.3	3060 0.033 10.0	3300 0.035 10.8	3580 0.038 11.7	3910 0.042 12.8	4280 0.046 14.0	4700 0.051 15.4	5170 0.056 17.0	5640 0.061 18.5	6200 0.067 20.3	6860 0.074 22.5	7240 0.078 23.7	7610 0.082 25.0	8460 0.091 27.7	9390 0.101 30.8	10330 0.111 33.9	11460 0.123 37.6	12680 0.136 41.6	14090 0.151 46.2
24.8 in. 630	2210 0.024 7.3	2540 0.027 8.3	2730 0.029 9.0	2920 0.031 9.6	3150 0.034 10.3	3390 0.036 11.1	3670 0.039 12.0	4000 0.043 13.1	4370 0.047 14.3	4790 0.052 15.7	5260 0.057 17.3	5730 0.062 18.8	6300 0.068 20.6	6950 0.075 22.8	7330 0.079 24.0	7700 0.083 25.3	8550 0.092 28.0	9490 0.102 31.1	10420 0.112 34.2	11550 0.124 37.9	12770 0.137 41.9	14180 0.152 46.5
26.4 in. 670	2270 0.024 7.4	2600 0.028 8.5	2780 0.030 9.1	2970 0.032 9.7	3210 0.034 10.5	3440 0.037 11.3	3720 0.040 12.2	4050 0.044 13.3	4430 0.048 14.5	4850 0.052 15.9	5320 0.057 17.4	5790 0.062 19.0	6350 0.068 20.8	7010 0.075 23.0	7380 0.079 24.2	7760 0.083 25.4	8600 0.092 28.2	9540 0.103 31.3	10480 0.113 34.4	11600 0.125 38.0	12820 0.138 42.0	14230 0.153 46.7
28 in. 710	2320 0.025 7.6	2650 0.028 8.7	2840 0.030 9.3	3020 0.033 9.9	3260 0.035 10.7	3490 0.038 11.5	3770 0.041 12.4	4100 0.044 13.5	4480 0.048 14.7	4900 0.053 16.1	5370 0.058 17.6	5840 0.063 19.1	6400 0.069 21.0	7060 0.076 23.1	7430 0.080 24.4	7810 0.084 25.6	8650 0.093 28.4	9590 0.103 31.4	10530 0.113 34.5	11660 0.125 38.2	12880 0.138 42.2	14280 0.154 46.8
31.5 in. 800	2440 0.026 8.0	2770 0.030 9.1	2950 0.032 9.7	3140 0.034 10.3	3380 0.036 11.1	3610 0.039 11.8	3890 0.042 12.8	4220 0.045 13.8	4600 0.049 15.1	5020 0.054 16.5	5490 0.059 18.0	5960 0.064 19.5	6520 0.070 21.4	7180 0.077 23.5	7550 0.081 24.8	7930 0.085 26.0	8770 0.094 28.8	9710 0.104 31.8	10650 0.114 34.9	11770 0.127 38.6	12990 0.140 42.6	14400 0.155 47.2

Terminal L_u mm \longleftarrow

Four-Shank KANTHAL SUPER 1700 9/18

Power W
Resistance Ω
Volt V

Max. element temperature 1700 °C (3090 °F) Heating zone \varnothing mm 9 Furnace temp. °C 1300 (2370° F) Element current A 305
Terminal \varnothing mm 18 Element temp. °C 1550 (2820° F) Surface loading W/cm² 16.6
Shank distance mm 60 W/in.² 107

Heating zone, L_e mm →

	7.1 in. 180	8.9 in. 225	10.6 in. 270	12.2 in. 310	13.8 in. 350	15.8 in. 400	17.7 in. 450	20.5 in. 520	23.6 in. 600	26.4 in. 670	28.4 in. 720
17.7 in. 450	4420 0.048 14.5	5260 0.057 17.3	6110 0.066 20.0	6860 0.074 22.5	7610 0.082 24.9	8550 0.092 28.0	9490 0.102 31.1	10800 0.116 35.4	12300 0.132 40.3	13610 0.146 44.6	14550 0.156 47.7
19.7 in. 500	4480 0.048 14.7	5330 0.057 17.5	6170 0.066 20.2	6920 0.074 22.7	7670 0.083 25.2	8610 0.093 28.2	9550 0.103 31.3	10870 0.117 35.6	12370 0.133 40.5	13680 0.147 44.9	14620 0.157 47.9
22 in. 560	4560 0.049 15.0	5410 0.058 17.7	6250 0.067 20.5	7000 0.075 23.0	7750 0.083 25.4	8690 0.093 28.5	9630 0.104 31.6	10940 0.118 35.9	12450 0.134 40.8	13760 0.148 45.1	14700 0.158 48.2
24 in. 610	4630 0,050 15.2	5470 0,059 17.9	6320 0,068 20.7	7070 0,076 23.2	7820 0,084 25.6	8760 0,094 28.7	9700 0,104 31.8	11010 0,118 36.1	12510 0,134 41.0	13820 0,149 45.3	14760 0,159 48.4
26.4 in. 670	4710 0.051 15.4	5550 0.060 18.2	6400 0.069 21.0	7150 0.077 23.4	7900 0.085 25.9	8840 0.095 29.0	9780 0.105 32.1	11090 0.119 36.4	12590 0.135 41.3	13900 0.149 45.6	14840 0.160 48.7
28.5 in. 725	4780 0.051 15.7	5630 0.060 18.4	6470 0.070 21.2	7220 0.078 23.7	7970 0.086 26.1	8910 0.096 29.2	9850 0.106 32.3	11160 0.120 36.6	12660 0.136 41.5	13980 0.150 45.8	14910 0.160 48.9
30.3 in. 770	4840 0.052 15.9	5680 0.061 18.6	6530 0.070 21.4	7280 0.078 23.9	8030 0.086 26.3	8970 0.096 29.4	9910 0.106 32.5	11220 0.121 36.8	12720 0.137 41.7	14040 0.151 46.0	14970 0.161 49.1

Terminal L_u mm

Four-Shank KANTHAL SUPER 1700 12/24

Power W
Resistance Ω
Volt V

Max. element temperature 1700 °C (3090 °F) Heating zone \varnothing mm 12 Furnace temp. °C 1300 (2370° F) Element current A 470
Terminal \varnothing mm 24 Element temp. °C 1550 (2820° F) Surface loading W/cm² 16.6
Shank distance mm 60 W/in.² 107

Heating zone, L_e mm \longrightarrow

	7.1 in. 180	8.9 in. 225	10.6 in. 270	12.2 in. 310	13.8 in. 350	15.8 in. 400	17.7 in. 450	20.5 in. 520	23.6 in. 600	26.4 in. 670	28.4 in. 720
17.7 in. 450	5850 0.026 12.4	6970 0.032 14.8	8100 0.037 17.2	9100 0.041 19.4	10110 0.046 21.5	11360 0.051 24.2	12610 0.057 26.8	14370 0.065 30.6	16370 0.074 34.8	18130 0.082 38.6	19380 0.088 41.2
19.7 in. 500	5930 0.027 12.6	7060 0.032 15.0	8190 0.037 17.4	9190 0.042 19.6	10200 0.046 21.7	11450 0.052 24.4	12700 0.058 27.0	14460 0.065 30.8	16460 0.075 35.0	18220 0.082 38.8	19470 0.088 41.4
22 in. 560	6040 0.027 12.8	7170 0.032 15.2	8300 0.038 17.6	9300 0.042 19.8	10300 0.047 21.9	11550 0.052 24.6	12810 0.058 27.2	14560 0.066 31.0	16570 0.075 35.2	18320 0.083 39.0	19580 0.089 41.6
24 in. 610	6130 0.028 13.0	7260 0.033 15.4	8380 0.038 17.8	9390 0.042 20.0	10390 0.047 22.1	11640 0.053 24.8	12900 0.058 27.4	14650 0.066 31.2	16660 0.075 35.4	18410 0.083 39.2	19660 0.089 41.8
26.4 in. 670	6230 0.028 13.3	7360 0.033 15.7	8490 0.038 18.1	9490 0.043 20.2	10490 0.048 22.3	11750 0.053 25.0	13000 0.059 27.7	14760 0.067 31.4	16760 0.076 35.7	18520 0.084 39.4	19770 0.089 42.1
28.5 in. 725	6330 0.029 13.5	7460 0.034 15.9	8590 0.039 18.3	9590 0.043 20.4	10590 0.048 22.5	11840 0.054 25.2	13100 0.059 27.9	14850 0.067 31.6	16860 0.076 35.9	18610 0.084 39.6	19870 0.090 42.3
30.3 in. 770	6410 0.029 13.6	7540 0.034 16.0	8660 0.039 18.4	9670 0.044 20.6	10670 0.048 22.7	11920 0.054 25.4	13180 0.060 28.0	14930 0.068 31.8	16940 0.077 36.0	18690 0.085 39.8	19940 0.090 42.4

Terminal L_t mm \longleftarrow

Two-Shank KANTHAL SUPER 1700 12/24

Power W
Resistance Ω
Volt V

Max. element temperature 1700 °C (3090 °F) Heating zone \varnothing mm 12 Terminal \varnothing mm 24 Shank distance mm 80
 Furnace temp. °C 1300 (2370° F) Element temp. °C 1550 (2820° F)
 Element current A 470 Surface loading W/cm² 16.6 W/in.² 107

Heating zone, L_e mm \longrightarrow

Terminal L_u mm \downarrow	4.9 in.	6.3 in.	7.1 in.	7.9 in.	8.9 in.	9.8 in.	11 in.	12.4 in.	14 in.	15.8 in.	17.7 in.	19.7 in.	22 in.	24.8 in.	26.4 in.	28 in.	31.5 in.	35.4 in.	39.4 in.	44.1 in.	49.2 in.	55.1 in.
	125	160	180	200	225	250	280	315	355	400	450	500	560	630	670	710	800	900	1000	1120	1250	1400
11 in.	2390	2830	3080	3330	3650	3960	4340	4780	5280	5840	6470	7090	7850	8720	9230	9730	10850	12110	13360	14870	16490	18370
280	0.011	0.013	0.014	0.015	0.017	0.018	0.020	0.022	0.024	0.026	0.029	0.032	0.036	0.039	0.042	0.044	0.049	0.055	0.060	0.067	0.075	0.083
	5.1	6.0	6.6	7.1	7.8	8.4	9.2	10.2	11.2	12.4	13.8	15.1	16.7	18.6	19.6	20.7	23.1	25.8	28.4	31.6	35.1	39.1
12.4 in.	2460	2900	3150	3400	3710	4020	4400	4840	5340	5900	6530	7160	7910	8790	9290	9790	10920	12170	13420	14930	16560	18440
315	0.011	0.013	0.014	0.015	0.017	0.018	0.020	0.022	0.024	0.027	0.030	0.032	0.036	0.040	0.042	0.044	0.049	0.055	0.061	0.068	0.075	0.083
	5.2	6.2	6.7	7.2	7.9	8.6	9.4	10.3	11.4	12.6	13.9	15.2	16.8	18.7	19.8	20.8	23.2	25.9	28.6	31.8	35.2	39.2
14 in.	2530	2970	3220	3470	3780	4090	4470	4910	5410	5970	6600	7230	7980	8860	9360	9860	10990	12240	13490	15000	16630	18510
355	0.011	0.013	0.015	0.016	0.017	0.019	0.020	0.022	0.024	0.027	0.030	0.033	0.036	0.040	0.042	0.045	0.050	0.055	0.061	0.068	0.075	0.084
	5.4	6.3	6.8	7.4	8.0	8.7	9.5	10.4	11.5	12.7	14.0	15.4	17.0	18.8	19.9	21.0	23.4	26.0	28.7	31.9	35.4	39.4
15.8 in.	2610	3040	3300	3550	3860	4170	4550	4990	5490	6050	6680	7310	8060	8940	9440	9940	11070	12320	13570	15080	16710	18590
400	0.012	0.014	0.015	0.016	0.017	0.019	0.021	0.023	0.025	0.027	0.030	0.033	0.036	0.040	0.043	0.045	0.050	0.056	0.061	0.068	0.076	0.084
	5.5	6.5	7.0	7.5	8.2	8.9	9.7	10.6	11.7	12.9	14.2	15.5	17.1	19.0	20.1	21.1	23.5	26.2	28.9	32.1	35.5	39.5
17.7 in.	2690	3130	3380	3630	3950	4260	4640	5080	5580	6140	6770	7390	8150	9020	9520	10030	11150	12410	13660	15160	16790	18670
450	0.012	0.014	0.015	0.016	0.018	0.019	0.021	0.023	0.025	0.028	0.031	0.033	0.037	0.041	0.043	0.045	0.050	0.056	0.062	0.069	0.076	0.085
	5.7	6.7	7.2	7.7	8.4	9.1	9.9	10.8	11.9	13.1	14.4	15.7	17.3	19.2	20.3	21.3	23.7	26.4	29.1	32.3	35.7	39.7
19.7 in.	2780	3220	3470	3720	4040	4350	4720	5160	5660	6230	6860	7480	8230	9110	9610	10110	11240	12490	13750	15250	16880	18760
500	0.013	0.015	0.016	0.017	0.018	0.020	0.021	0.023	0.026	0.028	0.031	0.034	0.037	0.041	0.044	0.046	0.051	0.057	0.062	0.069	0.076	0.085
	5.9	6.9	7.4	7.9	8.6	9.3	10.1	11.0	12.1	13.3	14.6	15.9	17.5	19.4	20.5	21.5	23.9	26.6	29.3	32.5	35.9	39.9
22 in.	2890	3330	3580	3830	4140	4450	4830	5270	5770	6330	6960	7590	8340	9220	9720	10220	11350	12600	13850	15360	16990	18870
560	0.013	0.015	0.016	0.017	0.019	0.020	0.022	0.024	0.026	0.029	0.032	0.034	0.038	0.042	0.044	0.046	0.051	0.057	0.063	0.070	0.077	0.085
	6.1	7.1	7.6	8.1	8.8	9.5	10.3	11.2	12.3	13.5	14.8	16.1	17.7	19.6	20.7	21.7	24.1	26.8	29.5	32.7	36.1	40.1
24.8 in.	3010	3450	3700	3950	4260	4580	4950	5390	5890	6460	7080	7710	8460	9340	9840	10340	11470	12720	13980	15480	17110	18990
630	0.014	0.016	0.017	0.018	0.019	0.021	0.022	0.024	0.027	0.029	0.032	0.035	0.038	0.042	0.045	0.047	0.052	0.058	0.063	0.070	0.077	0.086
	6.4	7.3	7.9	8.4	9.1	9.7	10.5	11.5	12.5	13.7	15.1	16.4	18.0	19.9	20.9	22.0	24.4	27.1	29.7	32.9	36.4	40.4
26.4 in.	3080	3520	3770	4020	4330	4650	5020	5460	5960	6530	7150	7780	8530	9410	9910	10410	11540	12790	14050	15550	17180	19060
670	0.014	0.016	0.017	0.018	0.020	0.021	0.023	0.025	0.027	0.030	0.032	0.035	0.039	0.043	0.045	0.047	0.052	0.058	0.064	0.070	0.078	0.086
	6.6	7.5	8.0	8.6	9.2	9.9	10.7	11.6	12.7	13.9	15.2	16.6	18.2	20.0	21.1	22.2	24.6	27.2	29.9	33.1	36.6	40.6
28 in.	3150	3590	3840	4090	4400	4720	5090	5530	6030	6600	7220	7850	8600	9480	9980	10480	11610	12860	14120	15620	17250	19130
710	0.014	0.016	0.017	0.019	0.020	0.021	0.023	0.025	0.027	0.030	0.033	0.036	0.039	0.043	0.045	0.047	0.053	0.058	0.064	0.071	0.078	0.087
	6.7	7.6	8.2	8.7	9.4	10.0	10.8	11.8	12.8	14.0	15.4	16.7	18.3	20.2	21.2	22.3	24.7	27.4	30.0	33.2	36.7	40.7
31.5 in.	3310	3750	4000	4250	4560	4880	5250	5690	6190	6760	7380	8010	8760	9640	10140	10640	11770	13020	14280	15780	17410	19290
800	0.015	0.017	0.018	0.019	0.021	0.022	0.024	0.026	0.028	0.031	0.033	0.036	0.040	0.044	0.046	0.048	0.053	0.059	0.065	0.071	0.079	0.087
	7.0	8.0	8.5	9.0	9.7	10.4	11.2	12.1	13.2	14.4	15.7	17.0	18.6	20.5	21.6	22.6	25.0	27.7	30.4	33.6	37.0	41.0

Two-Shank KANTHAL SUPER 1800 3/6

Power W
Resistance Ω
Volt V

Max. element temperature 1800 °C (3270 °F) Heating zone Ø mm 3 Furnace temp. °C 1600 (2910° F) Element current A 48
Terminal Ø mm 6 Element temp. °C 1700 (3090° F) Surface loading W/cm² 12.0
Shank distance mm 25 W/in² 77

Heating zone, L_e mm →

Terminal L_u mm ↓

	2 in.	3 in.	3.9 in.	4.9 in.	6.3 in.	7.1 in.	7.9 in.	8.9 in.	9.8 in.	11 in.	12.4 in.	14 in.	15.8 in.
	50	75	100	125	160	180	200	225	250	280	315	355	400
2 in.	166	223	279	336	415	460	505	562	618	686	765	855	957
50	0.074	0.099	0.124	0.149	0.184	0.204	0.224	0.249	0.274	0.304	0.339	0.379	0.424
	3.5	4.7	5.9	7.1	8.7	9.7	10.6	11.8	13.0	14.4	16.1	18.0	20.1
3 in.	175	232	288	345	424	469	514	571	627	695	774	864	966
75	0.078	0.103	0.128	0.153	0.188	0.208	0.228	0.253	0.278	0.308	0.343	0.383	0.428
	3.7	4.9	6.1	7.3	8.9	9.9	10.8	12.0	13.2	14.6	16.3	18.2	20.3
3.9 in.	184	241	297	354	433	478	523	580	636	704	783	873	975
100	0.082	0.107	0.132	0.157	0.192	0.212	0.232	0.257	0.282	0.312	0.347	0.387	0.432
	3.9	5.1	6.3	7.4	9.1	10.1	11.0	12.2	13.4	14.8	16.5	18.4	20.5
4.9 in.	193	250	306	363	442	487	532	589	645	713	792	882	984
125	0.086	0.111	0.136	0.161	0.196	0.216	0.236	0.261	0.286	0.316	0.351	0.391	0.436
	4.1	5.3	6.4	7.6	9.3	10.3	11.2	12.4	13.6	15.0	16.7	18.6	20.7
5.5 in.	199	255	312	368	447	492	538	594	651	718	797	888	989
140	0.088	0.113	0.138	0.163	0.198	0.218	0.238	0.263	0.288	0.318	0.353	0.393	0.438
	4.2	5.4	6.6	7.8	9.4	10.4	11.3	12.5	13.7	15.1	16.8	18.7	20.8
6.3 in.	206	262	319	375	454	500	545	601	658	726	805	895	997
160	0.091	0.116	0.141	0.166	0.201	0.221	0.241	0.267	0.292	0.322	0.357	0.397	0.442
	4.3	5.5	6.7	7.9	9.6	10.5	11.5	12.7	13.8	15.3	16.9	18.8	21.0
7.1 in.	213	270	326	383	462	507	552	609	665	733	812	902	1004
180	0.095	0.120	0.145	0.170	0.205	0.225	0.245	0.270	0.295	0.325	0.360	0.400	0.445
	4.5	5.7	6.9	8.1	9.7	10.7	11.6	12.8	14.0	15.4	17.1	19.0	21.1
7.9 in.	220	277	333	390	469	514	559	616	672	740	819	909	1011
200	0.098	0.123	0.148	0.173	0.208	0.228	0.248	0.273	0.298	0.328	0.363	0.403	0.448
	4.6	5.8	7.0	8.2	9.9	10.8	11.8	13.0	14.2	15.6	17.2	19.1	21.3
8.9 in.	229	286	342	399	478	523	568	625	681	749	828	918	1020
225	0.102	0.127	0.152	0.177	0.212	0.232	0.252	0.277	0.302	0.332	0.367	0.407	0.452
	4.8	6.0	7.2	8.4	10.1	11.0	12.0	13.2	14.3	15.8	17.4	19.3	21.5
9.8 in.	239	295	351	408	487	532	577	634	690	758	837	927	1029
250	0.106	0.131	0.156	0.181	0.216	0.236	0.256	0.281	0.306	0.336	0.371	0.411	0.456
	5.0	6.2	7.4	8.6	10.3	11.2	12.2	13.3	14.5	16.0	17.6	19.5	21.7
11 in.	249	306	362	419	498	543	588	645	701	769	848	938	1040
280	0.111	0.136	0.161	0.186	0.221	0.241	0.261	0.286	0.311	0.341	0.376	0.416	0.461
	5.2	6.4	7.6	8.8	10.5	11.4	12.4	13.6	14.8	16.2	17.9	19.8	21.9
12.4 in.	262	318	375	431	510	556	601	657	714	781	861	951	1053
315	0.116	0.141	0.166	0.191	0.226	0.246	0.266	0.291	0.316	0.346	0.381	0.421	0.467
	5.5	6.7	7.9	9.1	10.7	11.7	12.6	13.8	15.0	16.5	18.1	20.0	22.2
14 in.	276	333	389	446	525	570	615	672	728	796	875	965	1067
355	0.123	0.148	0.173	0.198	0.233	0.253	0.273	0.298	0.323	0.353	0.388	0.428	0.473
	5.8	7.0	8.2	9.4	11.1	12.0	13.0	14.1	15.3	16.8	18.4	20.3	22.5
15.8 in.	293	349	406	462	541	586	631	688	744	812	891	982	1083
400	0.130	0.155	0.180	0.205	0.240	0.260	0.280	0.305	0.330	0.360	0.395	0.435	0.480
	6.2	7.4	8.5	9.7	11.4	12.3	13.3	14.5	15.7	17.1	18.8	20.7	22.8

Two-Shank KANTHAL SUPER 1800 4/9

Power W
Resistance Ω
Volt V

Max. element temperature 1800 °C (3270 °F) Heating zone Ø mm 4 Furnace temp. °C 1600 (2910 °F) Element current A 73
Terminal Ø mm 9 Element temp. °C 1700 (2090 °F) Surface loading W/cm² 12.0
Shank distance mm 25 W/in.² 77

Heating zone, L_e mm →

Terminal L_t mm ↓

	2 in. 50	3 in. 75	3.9 in. 100	4.9 in. 125	6.3 in. 160	7.1 in. 180	7.9 in. 200	8.9 in. 225	9.8 in. 250	11 in. 280	12.4 in. 315	14 in. 355	15.8 in. 400
2 in. 50	215 0.040 2.9	291 0.054 4.0	366 0.068 5.0	441 0.082 6.0	547 0.102 7.5	607 0.113 8.3	667 0.125 9.1	743 0.139 10.2	818 0.153 11.2	909 0.170 12.4	1014 0.189 13.9	1135 0.212 15.5	1270 0.237 17.4
3 in. 75	225 0.042 3.1	300 0.056 4.1	376 0.070 5.1	451 0.084 6.2	556 0.104 7.6	617 0.115 8.4	677 0.126 9.3	752 0.141 10.3	828 0.155 11.3	918 0.172 12.5	1024 0.191 14.0	1144 0.214 15.6	1280 0.239 17.5
3.9 in. 100	234 0.044 3.2	310 0.058 4.2	385 0.072 5.3	460 0.086 6.3	566 0.106 7.7	626 0.117 8.6	686 0.128 9.4	762 0.142 10.4	837 0.156 11.4	928 0.173 12.7	1033 0.193 14.1	1154 0.216 15.8	1289 0.241 17.6
4.9 in. 125	244 0.046 3.3	319 0.060 4.4	395 0.074 5.4	470 0.088 6.4	575 0.108 7.9	636 0.119 8.7	696 0.130 9.5	771 0.144 10.5	847 0.158 11.6	937 0.175 12.8	1043 0.195 14.3	1163 0.217 15.9	1299 0.243 17.8
5.5 in. 140	250 0.047 3.4	325 0.061 4.4	400 0.075 5.5	476 0.089 6.5	581 0.109 7.9	641 0.120 8.8	702 0.131 9.6	777 0.145 10.6	852 0.159 11.7	943 0.176 12.9	1048 0.196 14.3	1169 0.218 16.0	1305 0.244 17.8
6.3 in. 160	257 0.048 3.5	333 0.062 4.5	408 0.076 5.6	483 0.090 6.6	589 0.110 8.0	649 0.121 8.9	709 0.133 9.7	785 0.147 10.7	860 0.161 11.8	950 0.178 13.0	1056 0.197 14.4	1176 0.220 16.1	1312 0.245 17.9
7.1 in. 180	265 0.049 3.6	340 0.064 4.6	416 0.078 5.7	491 0.092 6.7	596 0.111 8.2	657 0.123 9.0	717 0.134 9.8	792 0.148 10.8	868 0.162 11.9	958 0.179 13.1	1064 0.199 14.5	1184 0.221 16.2	1320 0.247 18.0
7.9 in. 200	272 0.051 3.7	348 0.065 4.8	423 0.079 5.8	498 0.093 6.8	604 0.113 8.3	664 0.124 9.1	725 0.135 9.9	800 0.149 10.9	875 0.164 12.0	966 0.180 13.2	1071 0.200 14.6	1192 0.223 16.3	1327 0.248 18.1
8.9 in. 225	282 0.053 3.9	357 0.067 4.9	433 0.081 5.9	508 0.095 6.9	614 0.115 8.4	674 0.126 9.2	734 0.137 10.0	809 0.151 11.1	885 0.165 12.1	975 0.182 13.3	1081 0.202 14.8	1201 0.224 16.4	1337 0.250 18.3
9.8 in. 250	291 0.054 4.0	367 0.069 5.0	442 0.083 6.0	518 0.097 7.1	623 0.116 8.5	683 0.128 9.3	744 0.139 10.2	819 0.153 11.2	894 0.167 12.2	985 0.184 13.5	1090 0.204 14.9	1211 0.226 16.5	1346 0.252 18.4
11 in. 280	303 0.057 4.1	378 0.071 5.2	454 0.085 6.2	529 0.099 7.2	634 0.119 8.7	695 0.130 9.5	755 0.141 10.3	830 0.155 11.3	906 0.169 12.4	996 0.186 13.6	1102 0.206 15.1	1222 0.228 16.7	1358 0.254 18.6
12.4 in. 315	316 0.059 4.3	392 0.073 5.4	467 0.087 6.4	542 0.101 7.4	648 0.121 8.9	708 0.132 9.7	768 0.144 10.5	844 0.158 11.5	919 0.172 12.6	1009 0.189 13.8	1115 0.208 15.2	1236 0.231 16.9	1371 0.256 18.7
14 in. 355	331 0.062 4.5	407 0.076 5.6	482 0.090 6.6	558 0.104 7.6	663 0.124 9.1	723 0.135 9.9	784 0.146 10.7	859 0.160 11.7	934 0.175 12.8	1025 0.191 14.0	1130 0.211 15.4	1251 0.234 17.1	1386 0.259 18.9
15.8 in. 400	349 0.065 4.8	424 0.079 5.8	499 0.093 6.8	575 0.107 7.9	680 0.127 9.3	740 0.138 10.1	801 0.150 10.9	876 0.164 12.0	951 0.178 13.0	1042 0.195 14.2	1147 0.214 15.7	1268 0.237 17.3	1404 0.262 19.2

Two-Shank KANTHAL SUPER 1800 6/12

Power W
Resistance Ω
Volt V

Max. element temperature 1800 °C (3270 °F) Heating zone Ø mm 6 Furnace temp. °C 1600 (2910° F) Element current A 134
Terminal Ø mm 12 Element temp. °C 1700 (2090° F) Surface loading W/cm² 12.0
Shank distance mm 50 W/in.² 77

Heating zone, L_e mm →

Terminal L_U mm ↓

	4.9 in. 125	6.3 in. 160	7.1 in. 180	7.9 in. 200	8.9 in. 225	9.8 in. 250	11 in. 280	12.4 in. 315	14 in. 355	15.8 in. 400	17.7 in. 450	19.7 in. 500	22 in. 560	24.8 in. 630	26.4 in. 670	28 in. 710	31.5 in. 800	35.4 in. 900	39.4 in. 1000
4.9 in. 125	750 0.042 5.6	910 0.050 6.8	1000 0.055 7.4	1090 0.060 8.1	1200 0.067 9.0	1320 0.073 9.8	1450 0.080 10.8	1610 0.089 12.0	1790 0.099 13.3	1990 0.110 14.8	2220 0.123 16.5	2450 0.135 18.2	2720 0.150 20.2	3030 0.168 22.6	3220 0.178 23.9	3400 0.188 25.3	3800 0.211 28.3	4260 0.236 31.7	4710 0.261 35.0
5.5 in. 140	760 0.042 5.7	920 0.051 6.8	1010 0.056 7.5	1100 0.061 8.2	1210 0.067 9.0	1330 0.073 9.9	1460 0.081 10.9	1620 0.090 12.1	1800 0.100 13.4	2010 0.111 14.9	2230 0.124 16.6	2460 0.136 18.3	2730 0.151 20.3	3050 0.169 22.7	3230 0.179 24.0	3410 0.189 25.4	3810 0.211 28.4	4270 0.236 31.7	4720 0.261 35.1
6.3 in. 160	780 0.043 5.8	940 0.052 7.0	1030 0.057 7.6	1120 0.062 8.3	1230 0.068 9.1	1340 0.074 10.0	1480 0.082 11.0	1640 0.091 12.2	1820 0.101 13.5	2020 0.112 15.0	2250 0.124 16.7	2470 0.137 18.4	2740 0.152 20.4	3060 0.169 22.8	3240 0.179 24.1	3420 0.189 25.5	3830 0.212 28.5	4280 0.237 31.8	4730 0.262 35.2
7.1 in. 180	790 0.044 5.9	950 0.053 7.1	1040 0.058 7.7	1130 0.063 8.4	1240 0.069 9.3	1360 0.075 10.1	1490 0.083 11.1	1650 0.091 12.3	1830 0.101 13.6	2030 0.113 15.1	2260 0.125 16.8	2490 0.138 18.5	2760 0.153 20.5	3070 0.170 22.9	3260 0.180 24.2	3440 0.190 25.6	3840 0.213 28.6	4290 0.238 32.0	4750 0.263 35.3
7.9 in. 200	810 0.045 6.0	960 0.053 7.2	1050 0.058 7.8	1140 0.063 8.5	1260 0.070 9.4	1370 0.076 10.2	1510 0.083 11.2	1660 0.092 12.4	1850 0.102 13.7	2050 0.113 15.2	2280 0.126 16.9	2500 0.138 18.6	2770 0.153 20.6	3090 0.171 23.0	3270 0.181 24.3	3450 0.191 25.7	3860 0.214 28.7	4310 0.239 32.1	4760 0.264 35.4
8.9 in. 225	820 0.046 6.1	980 0.054 7.3	1070 0.059 8.0	1160 0.064 8.7	1280 0.071 9.5	1390 0.077 10.3	1520 0.084 11.3	1680 0.093 12.5	1860 0.103 13.9	2070 0.114 15.4	2290 0.127 17.1	2520 0.139 18.7	2790 0.154 20.8	3110 0.172 23.1	3290 0.182 24.5	3470 0.192 25.8	3880 0.215 28.8	4330 0.240 32.2	4780 0.265 35.6
9.8 in. 250	840 0.047 6.3	1000 0.055 7.4	1090 0.060 8.1	1180 0.065 8.8	1290 0.072 9.6	1410 0.078 10.5	1540 0.085 11.5	1700 0.094 12.7	1880 0.104 14.0	2090 0.115 15.5	2310 0.128 17.2	2540 0.140 18.9	2810 0.155 20.9	3120 0.173 23.3	3310 0.183 24.6	3490 0.193 25.9	3890 0.216 29.0	4350 0.241 32.3	4800 0.266 35.7
11 in. 280	860 0.048 6.4	1020 0.057 7.6	1110 0.062 8.3	1200 0.067 8.9	1320 0.073 9.8	1430 0.079 10.6	1560 0.087 11.6	1720 0.095 12.8	1900 0.105 14.2	2110 0.117 15.7	2330 0.129 17.4	2560 0.142 19.0	2830 0.157 21.1	3150 0.174 23.4	3330 0.184 24.8	3510 0.194 26.1	3920 0.217 29.1	4370 0.242 32.5	4820 0.267 35.9
12.4 in. 315	890 0.049 6.6	1050 0.058 7.8	1140 0.063 8.5	1230 0.068 9.1	1340 0.074 10.0	1450 0.080 10.8	1590 0.088 11.8	1750 0.097 13.0	1930 0.107 14.4	2130 0.118 15.9	2360 0.131 17.5	2580 0.143 19.2	2860 0.158 21.2	3170 0.176 23.6	3350 0.186 24.9	3530 0.196 26.3	3940 0.218 29.3	4390 0.243 32.7	4840 0.268 36.0
14 in. 355	920 0.051 6.8	1080 0.060 8.0	1170 0.065 8.7	1260 0.070 9.4	1370 0.076 10.2	1480 0.082 11.0	1620 0.090 12.0	1780 0.098 13.2	1960 0.108 14.6	2160 0.120 16.1	2390 0.132 17.8	2610 0.145 19.4	2880 0.160 21.5	3200 0.177 23.8	3380 0.187 25.2	3560 0.197 26.5	3970 0.220 29.5	4420 0.245 32.9	4870 0.270 36.3
15.8 in. 400	950 0.053 7.1	1110 0.061 8.2	1200 0.066 8.9	1290 0.071 9.6	1400 0.078 10.4	1520 0.084 11.3	1650 0.091 12.3	1810 0.100 13.5	1990 0.110 14.8	2190 0.121 16.3	2420 0.134 18.0	2650 0.146 19.7	2920 0.161 21.7	3230 0.179 24.1	3410 0.189 25.4	3590 0.199 26.7	4000 0.222 29.8	4450 0.247 33.1	4910 0.272 36.5
17.7 in. 450	990 0.055 7.3	1140 0.063 8.5	1240 0.068 9.2	1330 0.073 9.9	1440 0.080 10.7	1550 0.086 11.5	1690 0.093 12.6	1850 0.102 13.7	2030 0.112 15.1	2230 0.123 16.6	2460 0.136 18.3	2680 0.148 20.0	2950 0.163 22.0	3270 0.181 24.3	3450 0.191 25.7	3630 0.201 27.0	4040 0.224 30.0	4490 0.249 33.4	4940 0.274 36.8
19.7 in. 500	1020 0.057 7.6	1180 0.065 8.8	1270 0.070 9.5	1360 0.075 10.1	1470 0.082 11.0	1590 0.088 11.8	1720 0.095 12.8	1880 0.104 14.0	2060 0.114 15.3	2270 0.125 16.9	2490 0.138 18.5	2720 0.150 20.2	2990 0.165 22.2	3310 0.183 24.6	3490 0.193 25.9	3670 0.203 27.3	4070 0.226 30.3	4530 0.251 33.7	4980 0.276 37.0
22 in. 560	1070 0.059 7.9	1220 0.068 9.1	1310 0.073 9.8	1400 0.078 10.5	1520 0.084 11.3	1630 0.090 12.1	1770 0.098 13.1	1920 0.107 14.3	2110 0.117 15.7	2310 0.128 17.2	2540 0.140 18.9	2760 0.153 20.5	3030 0.168 22.6	3350 0.185 24.9	3530 0.195 26.3	3710 0.205 27.6	4120 0.228 30.6	4570 0.253 34.0	5020 0.278 37.4
24.8 in. 630	1120 0.062 8.3	1270 0.071 9.5	1370 0.076 10.2	1460 0.081 10.8	1570 0.087 11.7	1680 0.093 12.5	1820 0.101 13.5	1980 0.109 14.7	2160 0.119 16.0	2360 0.131 17.6	2590 0.143 19.2	2810 0.156 20.9	3080 0.171 22.9	3400 0.188 25.3	3580 0.198 26.6	3760 0.208 28.0	4170 0.231 31.0	4620 0.256 34.4	5070 0.281 37.7
26.4 in. 670	1150 0.063 8.5	1300 0.072 9.7	1390 0.077 10.4	1480 0.082 11.0	1600 0.088 11.9	1710 0.095 12.7	1850 0.102 13.7	2000 0.111 14.9	2190 0.121 16.3	2390 0.132 17.8	2610 0.145 19.5	2840 0.157 21.1	3110 0.172 23.2	3430 0.190 25.5	3610 0.200 26.9	3790 0.210 28.2	4200 0.232 31.2	4650 0.257 34.6	5100 0.282 38.0
28 in. 710	1170 0.065 8.7	1330 0.074 9.9	1420 0.079 10.6	1510 0.084 11.3	1630 0.090 12.1	1740 0.096 12.9	1880 0.104 14.0	2030 0.113 15.1	2210 0.123 16.5	2420 0.134 18.0	2640 0.146 19.7	2870 0.159 21.4	3140 0.174 23.4	3460 0.191 25.7	3640 0.201 27.1	3820 0.211 28.4	4230 0.234 31.4	4680 0.259 34.8	5130 0.284 38.2
31.5 in. 800	1240 0.069 9.2	1400 0.077 10.4	1490 0.082 11.1	1580 0.087 11.7	1690 0.094 12.6	1800 0.100 13.4	1940 0.107 14.4	2100 0.116 15.6	2280 0.126 17.0	2480 0.137 18.5	2710 0.150 20.2	2930 0.162 21.8	3210 0.177 23.9	3520 0.195 26.2	3700 0.205 27.6	3880 0.215 28.9	4290 0.238 31.9	4740 0.263 35.3	5200 0.288 38.7

Two-Shank KANTHAL SUPER 1800 9/18

Power W
Resistance Ω
Volt V

Max. element temperature 1800 °C (3270 °F) Heating zone \varnothing mm 9 Furnace temp. °C 1600 (2910° F) Element current A 247
Terminal \varnothing mm 18 Element temp. °C 1700 (2090° F) Surface loading W/cm² 12.0
Shank distance mm 60 W/in² 77

Heating zone, L_e mm \longrightarrow

	4.9 in. 125	6.3 in. 160	7.1 in. 180	7.9 in. 200	8.9 in. 225	9.8 in. 250	11 in. 280	12.4 in. 315	14 in. 355	15.8 in. 400	17.7 in. 450	19.7 in. 500	22 in. 560	24.8 in. 630	26.4 in. 670	28 in. 710	31.5 in. 800	35.4 in. 900	39.4 in. 1000
11 in. 280	1310 0.021 5.3	1540 0.025 6.2	1680 0.028 6.8	1810 0.030 7.3	1980 0.033 8.0	2150 0.035 8.7	2360 0.039 9.5	2590 0.043 10.5	2870 0.047 11.6	3170 0.052 12.8	3510 0.058 14.2	3850 0.063 15.6	4260 0.070 17.2	4730 0.078 19.2	5000 0.082 20.3	5280 0.086 21.4	5890 0.096 23.8	6560 0.108 26.6	7240 0.119 29.3
12.4 in. 315	1340 0.022 5.4	1580 0.026 6.4	1720 0.028 7.0	1850 0.030 7.5	2020 0.033 8.2	2190 0.036 8.9	2400 0.039 9.7	2630 0.043 10.7	2900 0.048 11.8	3210 0.053 13.0	3550 0.058 14.4	3890 0.064 15.7	4300 0.070 17.4	4770 0.078 19.3	5040 0.083 20.4	5310 0.087 21.5	5920 0.097 24.0	6600 0.108 26.7	7280 0.119 29.5
14 in. 355	1390 0.023 5.6	1620 0.027 6.6	1760 0.029 7.1	1900 0.031 7.7	2070 0.034 8.4	2240 0.037 9.0	2440 0.040 9.9	2680 0.044 10.8	2950 0.048 11.9	3250 0.053 13.2	3590 0.059 14.5	3930 0.064 15.9	4340 0.071 17.6	4810 0.079 19.5	5090 0.083 20.6	5360 0.088 21.7	5970 0.098 24.2	6650 0.109 26.9	7320 0.120 29.7
15.8 in. 400	1440 0.024 5.8	1670 0.027 6.8	1810 0.030 7.3	1940 0.032 7.9	2110 0.035 8.6	2280 0.037 9.2	2490 0.041 10.1	2730 0.045 11.0	3000 0.049 12.1	3300 0.054 13.4	3640 0.060 14.7	3980 0.065 16.1	4390 0.072 17.8	4860 0.080 19.7	5130 0.084 20.8	5410 0.089 21.9	6020 0.099 24.4	6700 0.110 27.1	7370 0.121 29.9
17.7 in. 450	1490 0.024 6.0	1730 0.028 7.0	1860 0.031 7.5	2000 0.033 8.1	2170 0.036 8.8	2340 0.038 9.5	2540 0.042 10.3	2780 0.046 11.3	3050 0.050 12.4	3360 0.055 13.6	3700 0.061 15.0	4030 0.066 16.3	4440 0.073 18.0	4920 0.081 19.9	5190 0.085 21.0	5460 0.089 22.1	6070 0.100 24.6	6750 0.111 27.3	7430 0.122 30.1
19.7 in. 500	1540 0.025 6.3	1780 0.029 7.2	1920 0.031 7.8	2050 0.034 8.3	2220 0.036 9.0	2390 0.039 9.7	2600 0.043 10.5	2830 0.046 11.5	3110 0.051 12.6	3410 0.056 13.8	3750 0.061 15.2	4090 0.067 16.6	4500 0.074 18.2	4970 0.081 20.1	5240 0.086 21.2	5510 0.090 22.3	6120 0.100 24.8	6800 0.112 27.5	7480 0.123 30.3
22 in. 560	1610 0.026 6.5	1850 0.030 7.5	1980 0.032 8.0	2120 0.035 8.6	2290 0.038 9.3	2460 0.040 9.9	2660 0.044 10.8	2900 0.048 11.7	3170 0.052 12.8	3480 0.057 14.1	3810 0.063 15.4	4150 0.068 16.8	4560 0.075 18.5	5040 0.083 20.4	5310 0.087 21.5	5580 0.091 22.6	6190 0.101 25.1	6870 0.113 27.8	7550 0.124 30.6
24.8 in. 630	1690 0.028 6.8	1920 0.032 7.8	2060 0.034 8.3	2190 0.036 8.9	2360 0.039 9.6	2530 0.042 10.3	2740 0.045 11.1	2970 0.049 12.0	3250 0.053 13.1	3550 0.058 14.4	3890 0.064 15.8	4230 0.069 17.1	4640 0.076 18.8	5110 0.084 20.7	5380 0.088 21.8	5660 0.093 22.9	6270 0.103 25.4	6940 0.114 28.1	7620 0.125 30.9
26.4 in. 670	1730 0.028 7.0	1970 0.032 8.0	2100 0.034 8.5	2240 0.037 9.1	2410 0.039 9.7	2580 0.042 10.4	2780 0.046 11.3	3020 0.049 12.2	3290 0.054 13.3	3590 0.059 14.6	3930 0.064 15.9	4270 0.070 17.3	4680 0.077 18.9	5160 0.085 20.9	5430 0.089 22.0	5700 0.093 23.1	6310 0.103 25.5	6990 0.115 28.3	7670 0.126 31.0
28 in. 710	1770 0.029 7.2	2010 0.033 8.1	2150 0.035 8.7	2280 0.037 9.2	2450 0.040 9.9	2620 0.043 10.6	2820 0.046 11.4	3060 0.050 12.4	3330 0.055 13.5	3640 0.060 14.7	3980 0.065 16.1	4320 0.071 17.5	4720 0.077 19.1	5200 0.085 21.0	5470 0.089 22.1	5740 0.094 23.2	6350 0.104 25.7	7030 0.115 28.5	7710 0.126 31.2
31.5 in. 800	1870 0.031 7.6	2110 0.035 8.5	2240 0.037 9.1	2380 0.039 9.6	2550 0.042 10.3	2720 0.045 11.0	2920 0.048 11.8	3160 0.052 12.8	3430 0.056 13.9	3740 0.061 15.1	4080 0.067 16.5	4410 0.072 17.9	4820 0.079 19.5	5300 0.087 21.4	5570 0.091 22.5	5840 0.096 23.6	6450 0.106 26.1	7130 0.117 28.9	7810 0.128 31.6

Terminal L_u mm \downarrow

Two-Shank KANTHAL SUPER 1800 12/24

Power W
Resistance Ω
Volt V

Max. element temperature 1800 °C (3270 °F) Heating zone \varnothing mm 12 Furnace temp. °C 1600 (2910° F) Element current A 380
Terminal \varnothing mm 24 Element temp. °C 1700 (2090° F) Surface loading W/cm² 12.0
Shank distance mm 80 W/in.² 77

Heating zone, L_e mm \longrightarrow

	4.9 in. 125	6.3 in. 160	7.1 in. 180	7.9 in. 200	8.9 in. 225	9.8 in. 250	11 in. 280	12.4 in. 315	14 in. 355	15.8 in. 400	17.7 in. 450	19.7 in. 500	22 in. 560	24.8 in. 630	26.4 in. 670	28 in. 710	31.5 in. 800	35.4 in. 900	39.4 in. 1000
11 in.	1780	2090	2270	2450	2680	2910	3180	3490	3850	4260	4710	5160	5710	6340	6700	7060	7870	8780	9680
280	0.012	0.014	0.016	0.017	0.019	0.020	0.022	0.024	0.027	0.030	0.033	0.036	0.040	0.044	0.046	0.049	0.055	0.061	0.067
	4.7	5.5	6.0	6.5	7.1	7.6	8.4	9.2	10.1	11.2	12.4	13.6	15.0	16.7	17.6	18.6	20.7	23.1	25.5
12.4 in.	1830	2140	2320	2500	2730	2960	3230	3540	3900	4310	4760	5210	5760	6390	6750	7110	7930	8830	9730
315	0.013	0.015	0.016	0.017	0.019	0.020	0.022	0.025	0.027	0.030	0.033	0.036	0.040	0.044	0.047	0.049	0.055	0.061	0.067
	4.8	5.6	6.1	6.6	7.2	7.8	8.5	9.3	10.3	11.3	12.5	13.7	15.1	16.8	17.8	18.7	20.9	23.2	25.6
14 in.	1880	2200	2380	2560	2790	3010	3280	3600	3960	4370	4820	5270	5810	6450	6810	7170	7980	8890	9790
355	0.013	0.015	0.016	0.018	0.019	0.021	0.023	0.025	0.027	0.030	0.033	0.037	0.040	0.045	0.047	0.050	0.055	0.062	0.068
	5.0	5.8	6.3	6.7	7.3	7.9	8.6	9.5	10.4	11.5	12.7	13.9	15.3	17.0	17.9	18.9	21.0	23.4	25.8
15.8 in.	1950	2270	2450	2630	2850	3080	3350	3670	4030	4430	4890	5340	5880	6510	6870	7230	8050	8950	9850
400	0.013	0.016	0.017	0.018	0.020	0.021	0.023	0.025	0.028	0.031	0.034	0.037	0.041	0.045	0.048	0.050	0.056	0.062	0.068
	5.1	6.0	6.4	6.9	7.5	8.1	8.8	9.6	10.6	11.7	12.9	14.0	15.5	17.1	18.1	19.0	21.2	23.6	25.9
17.7 in.	2020	2340	2520	2700	2930	3150	3420	3740	4100	4510	4960	5410	5950	6580	6950	7310	8120	9020	9930
450	0.014	0.016	0.017	0.019	0.020	0.022	0.024	0.026	0.028	0.031	0.034	0.037	0.041	0.046	0.048	0.051	0.056	0.062	0.069
	5.3	6.2	6.6	7.1	7.7	8.3	9.0	9.8	10.8	11.9	13.0	14.2	15.7	17.3	18.3	19.2	21.4	23.7	26.1
19.7 in.	2090	2410	2590	2770	3000	3220	3490	3810	4170	4580	5030	5480	6020	6660	7020	7380	8190	9100	10000
500	0.014	0.017	0.018	0.019	0.021	0.022	0.024	0.026	0.029	0.032	0.035	0.038	0.042	0.046	0.049	0.051	0.057	0.063	0.069
	5.5	6.3	6.8	7.3	7.9	8.5	9.2	10.0	11.0	12.0	13.2	14.4	15.9	17.5	18.5	19.4	21.6	23.9	26.3
22 in.	2180	2500	2680	2860	3080	3310	3580	3900	4260	4670	5120	5570	6110	6740	7100	7470	8280	9180	10090
560	0.015	0.017	0.019	0.020	0.021	0.023	0.025	0.027	0.029	0.032	0.035	0.039	0.042	0.047	0.049	0.052	0.057	0.064	0.070
	5.7	6.6	7.0	7.5	8.1	8.7	9.4	10.3	11.2	12.3	13.5	14.7	16.1	17.7	18.7	19.6	21.8	24.2	26.5
24.8 in.	2280	2600	2780	2960	3190	3410	3680	4000	4360	4770	5220	5670	6210	6840	7210	7570	8380	9280	10190
630	0.016	0.018	0.019	0.020	0.022	0.024	0.025	0.028	0.030	0.033	0.036	0.039	0.043	0.047	0.050	0.052	0.058	0.064	0.071
	6.0	6.8	7.3	7.8	8.4	9.0	9.7	10.5	11.5	12.5	13.7	14.9	16.3	18.0	19.0	19.9	22.1	24.4	26.8
26.4 in.	2340	2660	2840	3020	3240	3470	3740	4060	4420	4820	5280	5730	6270	6900	7260	7620	8440	9340	10240
670	0.016	0.018	0.020	0.021	0.022	0.024	0.026	0.028	0.031	0.033	0.037	0.040	0.043	0.048	0.050	0.053	0.058	0.065	0.071
	6.2	7.0	7.5	7.9	8.5	9.1	9.8	10.7	11.6	12.7	13.9	15.1	16.5	18.2	19.1	20.1	22.2	24.6	27.0
28 in.	2400	2710	2890	3070	3300	3530	3800	4110	4480	4880	5330	5790	6330	6960	7320	7680	8500	9400	10300
710	0.017	0.019	0.020	0.021	0.023	0.024	0.026	0.028	0.031	0.034	0.037	0.040	0.044	0.048	0.051	0.053	0.059	0.065	0.071
	6.3	7.1	7.6	8.1	8.7	9.3	10.0	10.8	11.8	12.8	14.0	15.2	16.7	18.3	19.3	20.2	22.4	24.7	27.1
31.5 in.	2530	2840	3020	3200	3430	3660	3930	4240	4610	5010	5460	5920	6460	7090	7450	7810	8630	9530	10430
800	0.018	0.020	0.021	0.022	0.024	0.025	0.027	0.029	0.032	0.035	0.038	0.041	0.045	0.049	0.052	0.054	0.060	0.066	0.072
	6.7	7.5	8.0	8.4	9.0	9.6	10.3	11.2	12.1	13.2	14.4	15.6	17.0	18.7	19.6	20.6	22.7	25.1	27.5

Terminal L_u mm \downarrow

Two-Shank KANTHAL SUPER 1900 3/6

Power W
Resistance Ω
Volt V

Max. element temperature 1830 °C (3330 °F) Heating zone \varnothing mm 3 Furnace temp. °C 1750 (3180° F) Element current A 41
Terminal \varnothing mm 6 Element temp. °C 1800 (3270° F) Surface loading W/cm² 9.0
Shank distance mm 25 W/in.² 58

Heating zone, L_e mm \longrightarrow

	2 in. 50	3 in. 75	3.9 in. 100	4.9 in. 125	6.3 in. 160	7.1 in. 180	7.9 in. 200	8.9 in. 225	9.8 in. 250	11 in. 280	12.4 in. 315	14 in. 355	15.8 in. 400
2 in. 50	125 0.073 3.0	167 0.098 4.0	210 0.122 5.1	252 0.147 6.1	311 0.182 7.5	345 0.201 8.3	379 0.221 9.2	421 0.246 10.2	464 0.270 11.2	514 0.300 12.4	574 0.335 13.9	641 0.374 15.5	717 0.419 17.3
3 in. 75	132 0.077 3.2	174 0.102 4.2	217 0.126 5.2	259 0.151 6.3	318 0.186 7.7	352 0.205 8.5	386 0.225 9.3	428 0.250 10.3	471 0.275 11.4	521 0.304 12.6	581 0.339 14.0	648 0.378 15.7	724 0.423 17.5
3.9 in. 100	139 0.081 3.4	181 0.106 4.4	224 0.131 5.4	266 0.155 6.4	325 0.190 7.9	359 0.209 8.7	393 0.229 9.5	435 0.254 10.5	478 0.279 11.5	528 0.308 12.8	588 0.343 14.2	655 0.382 15.8	731 0.427 17.7
4.9 in. 125	146 0.085 3.5	188 0.110 4.6	231 0.135 5.6	273 0.159 6.6	332 0.194 8.0	366 0.214 8.8	400 0.233 9.7	442 0.258 10.7	485 0.283 11.7	535 0.312 12.9	595 0.347 14.4	662 0.386 16.0	738 0.431 17.8
5.5 in. 140	150 0.088 3.6	193 0.112 4.7	235 0.137 5.7	277 0.162 6.7	336 0.196 8.1	370 0.216 8.9	404 0.236 9.8	446 0.260 10.8	489 0.285 11.8	539 0.315 13.0	599 0.349 14.5	666 0.389 16.1	743 0.433 17.9
6.3 in. 160	156 0.091 3.8	198 0.116 4.8	240 0.140 5.8	283 0.165 6.8	342 0.200 8.3	376 0.219 9.1	410 0.239 9.9	452 0.264 10.9	494 0.288 11.9	545 0.318 13.2	604 0.353 14.6	672 0.392 16.2	748 0.437 18.1
7.1 in. 180	161 0.094 3.9	204 0.119 4.9	246 0.144 5.9	288 0.168 7.0	348 0.203 8.4	381 0.223 9.2	415 0.242 10.0	458 0.267 11.1	500 0.292 12.1	551 0.321 13.3	610 0.356 14.7	678 0.395 16.4	754 0.440 18.2
7.9 in. 200	167 0.097 4.0	209 0.122 5.1	252 0.147 6.1	294 0.172 7.1	353 0.206 8.5	387 0.226 9.3	421 0.246 10.2	463 0.270 11.2	506 0.295 12.2	556 0.325 13.4	616 0.359 14.9	683 0.399 16.5	759 0.443 18.3
8.9 in. 225	174 0.102 4.2	216 0.126 5.2	259 0.151 6.2	301 0.176 7.3	360 0.210 8.7	394 0.230 9.5	428 0.250 10.3	470 0.274 11.4	513 0.299 12.4	563 0.329 13.6	623 0.363 15.0	690 0.403 16.7	766 0.447 18.5
9.8 in. 250	181 0.106 4.4	223 0.130 5.4	266 0.155 6.4	308 0.180 7.4	367 0.214 8.9	401 0.234 9.7	435 0.254 10.5	477 0.278 11.5	520 0.303 12.5	570 0.333 13.8	630 0.367 15.2	697 0.407 16.8	773 0.451 18.7
11 in. 280	189 0.111 4.6	232 0.135 5.6	274 0.160 6.6	316 0.185 7.6	376 0.219 9.1	409 0.239 9.9	443 0.259 10.7	486 0.283 11.7	528 0.308 12.8	579 0.338 14.0	638 0.372 15.4	706 0.412 17.0	782 0.456 18.9
12.4 in. 315	199 0.116 4.8	242 0.141 5.8	284 0.166 6.9	326 0.190 7.9	385 0.225 9.3	419 0.245 10.1	453 0.264 10.9	495 0.289 12.0	538 0.314 13.0	589 0.343 14.2	648 0.378 15.6	715 0.417 17.3	792 0.462 19.1
14 in. 355	211 0.123 5.1	253 0.148 6.1	295 0.172 7.1	337 0.197 8.2	397 0.231 9.6	431 0.251 10.4	464 0.271 11.2	507 0.296 12.2	549 0.320 13.3	600 0.350 14.5	659 0.384 15.9	727 0.424 17.6	803 0.468 19.4
15.8 in. 400	223 0.130 5.4	265 0.155 6.4	308 0.180 7.4	350 0.204 8.5	409 0.239 9.9	443 0.259 10.7	477 0.278 11.5	519 0.303 12.5	562 0.328 13.6	612 0.357 14.8	672 0.392 16.2	739 0.431 17.9	815 0.476 19.7

Terminal L_u mm \longleftarrow

Two-Shank KANTHAL SUPER 1900 4/9

Power W
Resistance Ω
Volt V

Max. element temperature 1850 °C (3450 °F) Heating zone Ø mm 4 Furnace temp. °C 1775 (3220° F) Element current A 69
Terminal Ø mm 9 Element temp. °C 1830 (3330° F) Surface loading W/cm² 10.7
Shank distance mm 25 W/in² 69

Heating zone, L_e mm →

Terminal L_t mm ↓

	2 in.	3 in.	3.9 in.	4.9 in.	6.3 in.	7.1 in.	7.9 in.	8.9 in.	9.8 in.	11 in.	12.4 in.	14 in.	15.8 in.
	50	75	100	125	160	180	200	225	250	280	315	355	400
2 in. 50	193 0.040 2.8	260 0.055 3.8	327 0.069 4.7	395 0.083 5.7	489 0.103 7.1	543 0.114 7.9	596 0.125 8.6	664 0.139 9.6	731 0.154 10.6	812 0.170 11.8	906 0.190 13.1	1013 0.213 14.7	1135 0.238 16.4
3 in. 75	202 0.042 2.9	269 0.056 3.9	336 0.071 4.9	403 0.085 5.8	498 0.105 7.2	551 0.116 8.0	605 0.127 8.8	672 0.141 9.7	740 0.155 10.7	820 0.172 11.9	915 0.192 13.3	1022 0.215 14.8	1143 0.240 16.6
3.9 in. 100	210 0.044 3.0	278 0.058 4.0	345 0.072 5.0	412 0.087 6.0	506 0.106 7.3	560 0.118 8.1	614 0.129 8.9	681 0.143 9.9	749 0.157 10.8	829 0.174 12.0	923 0.194 13.4	1031 0.217 14.9	1152 0.242 16.7
4.9 in. 125	219 0.046 3.2	286 0.060 4.2	354 0.074 5.1	421 0.088 6.1	515 0.108 7.5	569 0.119 8.2	623 0.131 9.0	690 0.145 10.0	757 0.159 11.0	838 0.176 12.1	932 0.196 13.5	1040 0.218 15.1	1161 0.244 16.8
5.5 in. 140	224 0.047 3.3	292 0.061 4.2	359 0.075 5.2	426 0.090 6.2	520 0.109 7.5	574 0.121 8.3	628 0.132 9.1	695 0.146 10.1	763 0.160 11.1	843 0.177 12.2	937 0.197 13.6	1045 0.220 15.1	1166 0.245 16.9
6.3 in. 160	231 0.049 3.4	299 0.063 4.3	366 0.077 5.3	433 0.091 6.3	527 0.111 7.6	581 0.122 8.4	635 0.133 9.2	702 0.148 10.2	770 0.162 11.2	850 0.179 12.3	944 0.198 13.7	1052 0.221 15.2	1173 0.246 17.0
7.1 in. 180	238 0.050 3.5	306 0.064 4.4	373 0.078 5.4	440 0.092 6.4	534 0.112 7.7	588 0.124 8.5	642 0.135 9.3	709 0.149 10.3	777 0.163 11.3	857 0.180 12.4	952 0.200 13.8	1059 0.222 15.3	1180 0.248 17.1
7.9 in. 200	245 0.052 3.6	313 0.066 4.5	380 0.080 5.5	447 0.094 6.5	541 0.114 7.8	595 0.125 8.6	649 0.136 9.4	716 0.150 10.4	784 0.165 11.4	864 0.182 12.5	959 0.201 13.9	1066 0.224 15.5	1187 0.249 17.2
8.9 in. 225	254 0.053 3.7	322 0.068 4.7	389 0.082 5.6	456 0.096 6.6	550 0.116 8.0	604 0.127 8.8	658 0.138 9.5	725 0.152 10.5	792 0.166 11.5	873 0.183 12.7	967 0.203 14.0	1075 0.226 15.6	1196 0.251 17.3
9.8 in. 250	263 0.055 3.8	330 0.069 4.8	398 0.084 5.8	465 0.098 6.7	559 0.117 8.1	613 0.129 8.9	667 0.140 9.7	734 0.154 10.6	801 0.168 11.6	882 0.185 12.8	976 0.205 14.1	1084 0.228 15.7	1205 0.253 17.5
11 in. 280	274 0.057 4.0	341 0.072 4.9	408 0.086 5.9	475 0.100 6.9	570 0.120 8.3	623 0.131 9.0	677 0.142 9.8	744 0.156 10.8	812 0.170 11.8	892 0.187 12.9	987 0.207 14.3	1094 0.230 15.9	1215 0.255 17.6
12.4 in. 315	286 0.060 4.1	353 0.074 5.1	420 0.088 6.1	488 0.102 7.1	582 0.122 8.4	636 0.134 9.2	689 0.145 10.0	757 0.159 11.0	824 0.173 11.9	905 0.190 13.1	999 0.210 14.5	1107 0.232 16.0	1228 0.258 17.8
14 in. 355	300 0.063 4.3	367 0.077 5.3	434 0.091 6.3	502 0.105 7.3	596 0.125 8.6	650 0.136 9.4	704 0.148 10.2	771 0.162 11.2	838 0.176 12.1	919 0.193 13.3	1013 0.213 14.7	1121 0.235 16.2	1242 0.261 18.0
15.8 in. 400	316 0.066 4.6	383 0.080 5.6	450 0.095 6.5	518 0.109 7.5	612 0.128 8.9	666 0.140 9.6	719 0.151 10.4	787 0.165 11.4	854 0.179 12.4	935 0.196 13.5	1029 0.216 14.9	1136 0.239 16.5	1257 0.264 18.2

Two-Shank KANTHAL SUPER 1900 6/12

Power W
Resistance Ω
Volt V

Max. element temperature 1850 °C (3360 °F) Heating zone \varnothing mm 6 Furnace temp. °C 1800 (3270° F) Element current A 125
Terminal \varnothing mm 12 Element temp. °C 1850 (3360° F) Surface loading W/cm² 10.5
Shank distance mm 50 W/in² 68

Heating zone, L_e mm \longrightarrow

	4.9 in. 125	6.3 in. 160	7.1 in. 180	7.9 in. 200	8.9 in. 225	9.8 in. 250	11 in. 280	12.4 in. 315	14 in. 355	15.8 in. 400	17.7 in. 450	19.7 in. 500	22 in. 560	24.8 in. 630	26.4 in. 670	28 in. 710
5.5 in. 140	680 0.043 5.4	810 0.052 6.5	890 0.057 7.2	970 0.062 7.8	1070 0.069 8.6	1170 0.075 9.4	1290 0.083 10.3	1430 0.092 11.4	1590 0.102 12.7	1770 0.113 14.1	1970 0.126 15.7	2160 0.139 17.3	2400 0.154 19.2	2680 0.172 21.4	2840 0.182 22.7	3000 0.192 24.0
6.3 in. 160	690 0.044 5.5	830 0.053 6.6	910 0.058 7.3	990 0.063 7.9	1090 0.070 8.7	1190 0.076 9.5	1300 0.083 10.4	1440 0.092 11.5	1600 0.103 12.8	1780 0.114 14.2	1980 0.127 15.8	2180 0.139 17.4	2420 0.155 19.3	2690 0.172 21.6	2850 0.183 22.8	3010 0.193 24.1
7.1 in. 180	700 0.045 5.6	840 0.054 6.7	920 0.059 7.4	1000 0.064 8.0	1100 0.070 8.8	1200 0.077 9.6	1320 0.084 10.5	1460 0.093 11.7	1620 0.103 12.9	1790 0.115 14.4	1990 0.128 15.9	2190 0.140 17.5	2430 0.155 19.4	2710 0.173 21.7	2870 0.183 22.9	3030 0.194 24.2
7.9 in. 200	720 0.046 5.7	860 0.055 6.8	930 0.060 7.5	1010 0.065 8.1	1110 0.071 8.9	1210 0.078 9.7	1330 0.085 10.7	1470 0.094 11.8	1630 0.104 13.0	1810 0.116 14.5	2010 0.128 16.1	2210 0.141 17.6	2440 0.156 19.5	2720 0.174 21.8	2880 0.184 23.0	3040 0.194 24.3
8.9 in. 225	730 0.047 5.9	870 0.056 7.0	950 0.061 7.6	1030 0.066 8.2	1130 0.072 9.0	1230 0.079 9.8	1350 0.086 10.8	1490 0.095 11.9	1650 0.105 13.2	1820 0.117 14.6	2020 0.130 16.2	2220 0.142 17.8	2460 0.157 19.7	2740 0.175 21.9	2900 0.185 23.2	3060 0.196 24.4
9.8 in. 250	750 0.048 6.0	890 0.057 7.1	970 0.062 7.7	1050 0.067 8.4	1150 0.073 9.2	1250 0.080 10.0	1370 0.087 10.9	1500 0.096 12.0	1660 0.106 13.3	1840 0.118 14.7	2040 0.131 16.3	2240 0.143 17.9	2480 0.159 19.8	2760 0.176 22.0	2910 0.186 23.3	3070 0.197 24.6
11 in. 280	770 0.049 6.2	910 0.058 7.3	990 0.063 7.9	1070 0.068 8.5	1170 0.075 9.3	1270 0.081 10.1	1390 0.089 11.1	1520 0.098 12.2	1680 0.108 13.5	1860 0.119 14.9	2060 0.132 16.5	2260 0.145 18.1	2500 0.160 20.0	2780 0.178 22.2	2930 0.188 23.5	3090 0.198 24.7
12.4 in. 315	790 0.051 6.4	930 0.060 7.5	1010 0.065 8.1	1090 0.070 8.7	1190 0.076 9.5	1290 0.083 10.3	1410 0.090 11.3	1550 0.099 12.4	1710 0.109 13.7	1890 0.121 15.1	2080 0.133 16.7	2280 0.146 18.3	2520 0.161 20.2	2800 0.179 22.4	2960 0.189 23.7	3120 0.199 24.9
14 in. 355	820 0.053 6.6	960 0.061 7.7	1040 0.067 8.3	1120 0.072 9.0	1220 0.078 9.7	1320 0.084 10.5	1440 0.092 11.5	1580 0.101 12.6	1730 0.111 13.9	1910 0.122 15.3	2110 0.135 16.9	2310 0.148 18.5	2550 0.163 20.4	2830 0.181 22.6	2990 0.191 23.9	3140 0.201 25.2
15.8 in. 400	850 0.055 6.8	990 0.063 7.9	1070 0.068 8.6	1150 0.074 9.2	1250 0.080 10.0	1350 0.086 10.8	1470 0.094 11.7	1610 0.103 12.8	1760 0.113 14.1	1940 0.124 15.5	2140 0.137 17.1	2340 0.150 18.7	2580 0.165 20.6	2860 0.183 22.9	3020 0.193 24.1	3170 0.203 25.4
14 in. 450	890 0.057 7.1	1020 0.066 8.2	1100 0.071 8.8	1180 0.076 9.5	1280 0.082 10.3	1380 0.088 11.1	1500 0.096 12.0	1640 0.105 13.1	1800 0.115 14.4	1980 0.127 15.8	2180 0.139 17.4	2370 0.152 19.0	2610 0.167 20.9	2890 0.185 23.1	3050 0.195 24.4	3210 0.205 25.7
15.8 in. 500	920 0.059 7.4	1060 0.068 8.5	1140 0.073 9.1	1220 0.078 9.7	1320 0.084 10.5	1420 0.091 11.3	1540 0.098 12.3	1670 0.107 13.4	1830 0.117 14.7	2010 0.129 16.1	2210 0.141 17.7	2410 0.154 19.3	2650 0.169 21.2	2920 0.187 23.4	3080 0.197 24.7	3240 0.207 25.9

Terminal L_u mm \downarrow

Two-Shank KANTHAL SUPER 1900 9/18

Power W
Resistance Ω
Volt V

Max. element temperature	1850 °C (3360 °F)	Heating zone \varnothing mm	9	Furnace temp. °C	1800 (3270° F)	Element current A	229
		Intermediate piece \varnothing mm	12	Element temp. °C	1850 (3450° F)	Surface loading W/cm ²	10.5
		Intermediate piece length mm	70			W/in ²	68
		Terminal \varnothing mm	18				
		Shank distance (a) mm	60				

		Heating zone, L_e mm \longrightarrow															
		4.9 in.	6.3 in.	7.1 in.	7.9 in.	8.9 in.	9.8 in.	11 in.	12.4 in.	14 in.	15.8 in.	17.7 in.	19.7 in.	22 in.	24.8 in.	26.4 in.	28 in.
		125	160	180	200	225	250	280	315	355	400	450	500	560	630	670	710
Terminal L_u mm \downarrow	9.8 in	1280	1490	1610	1730	1870	2020	2200	2410	2640	2910	3210	3500	3860	4270	4510	4750
	250	0.024	0.028	0.031	0.033	0.036	0.039	0.042	0.046	0.050	0.056	0.061	0.067	0.074	0.081	0.086	0.091
		5.6	6.5	7.0	7.5	8.2	8.8	9.6	10.5	11.5	12.7	14.0	15.3	16.9	18.7	19.7	20.7
11 in.	280	1310	1520	1640	1760	1910	2050	2230	2440	2680	2940	3240	3530	3890	4300	4540	4780
		0.025	0.029	0.031	0.034	0.036	0.039	0.043	0.046	0.051	0.056	0.062	0.067	0.074	0.082	0.087	0.091
		5.7	6.6	7.2	7.7	8.3	9.0	9.7	10.6	11.7	12.8	14.1	15.4	17.0	18.8	19.8	20.9
12.4 in.	315	1350	1560	1670	1790	1940	2090	2270	2470	2710	2980	3270	3570	3920	4340	4580	4810
		0.026	0.030	0.032	0.034	0.037	0.040	0.043	0.047	0.052	0.057	0.062	0.068	0.075	0.083	0.087	0.092
		5.9	6.8	7.3	7.8	8.5	9.1	9.9	10.8	11.8	13.0	14.3	15.6	17.1	18.9	20.0	21.0
14 in.	355	1390	1600	1710	1830	1980	2130	2310	2510	2750	3020	3310	3610	3960	4380	4620	4850
		0.026	0.030	0.033	0.035	0.038	0.041	0.044	0.048	0.052	0.058	0.063	0.069	0.076	0.084	0.088	0.093
		6.1	7.0	7.5	8.0	8.7	9.3	10.1	11.0	12.0	13.2	14.5	15.8	17.3	19.1	20.2	21.2
15.8 in.	400	1430	1640	1760	1880	2030	2170	2350	2560	2800	3060	3360	3660	4010	4430	4660	4900
		0.027	0.031	0.034	0.036	0.039	0.041	0.045	0.049	0.053	0.058	0.064	0.070	0.076	0.084	0.089	0.093
		6.3	7.2	7.7	8.2	8.8	9.5	10.3	11.2	12.2	13.4	14.7	16.0	17.5	19.3	20.4	21.4
17.7 in.	450	1490	1690	1810	1930	2080	2230	2400	2610	2850	3110	3410	3710	4060	4480	4710	4950
		0.028	0.032	0.035	0.037	0.040	0.042	0.046	0.050	0.054	0.059	0.065	0.071	0.077	0.085	0.090	0.094
		6.5	7.4	7.9	8.4	9.1	9.7	10.5	11.4	12.4	13.6	14.9	16.2	17.7	19.5	20.6	21.6
19.7 in.	500	1540	1740	1860	1980	2130	2280	2450	2660	2900	3160	3460	3760	4110	4530	4760	5000
		0.029	0.033	0.035	0.038	0.041	0.043	0.047	0.051	0.055	0.060	0.066	0.072	0.078	0.086	0.091	0.095
		6.7	7.6	8.1	8.6	9.3	9.9	10.7	11.6	12.7	13.8	15.1	16.4	18.0	19.8	20.8	21.8
22 in.	560	1600	1800	1920	2040	2190	2340	2510	2720	2960	3220	3520	3820	4170	4590	4820	5060
		0.030	0.034	0.037	0.039	0.042	0.045	0.048	0.052	0.056	0.061	0.067	0.073	0.080	0.087	0.092	0.097
		7.0	7.9	8.4	8.9	9.6	10.2	11.0	11.9	12.9	14.1	15.4	16.7	18.2	20.0	21.1	22.1
24.8 in.	630	1670	1870	1990	2110	2260	2410	2580	2790	3030	3300	3590	3890	4240	4660	4890	5130
		0.032	0.036	0.038	0.040	0.043	0.046	0.049	0.053	0.058	0.063	0.068	0.074	0.081	0.089	0.093	0.098
		7.3	8.2	8.7	9.2	9.9	10.5	11.3	12.2	13.2	14.4	15.7	17.0	18.5	20.3	21.4	22.4
26.4 in.	670	1710	1910	2030	2150	2300	2450	2630	2830	3070	3340	3630	3930	4280	4700	4940	5170
		0.033	0.037	0.039	0.041	0.044	0.047	0.050	0.054	0.059	0.064	0.069	0.075	0.082	0.090	0.094	0.099
		7.5	8.4	8.9	9.4	10.0	10.7	11.5	12.4	13.4	14.6	15.9	17.2	18.7	20.5	21.6	22.6
28 in.	710	1750	1960	2070	2190	2340	2490	2670	2870	3110	3380	3670	3970	4320	4740	4980	5210
		0.033	0.037	0.040	0.042	0.045	0.047	0.051	0.055	0.059	0.064	0.070	0.076	0.082	0.090	0.095	0.099
		7.6	8.5	9.1	9.6	10.2	10.9	11.6	12.5	13.6	14.7	16.0	17.3	18.9	20.7	21.7	22.8

Fig. 25 Pusher furnace for melting and burn-out of moulds.

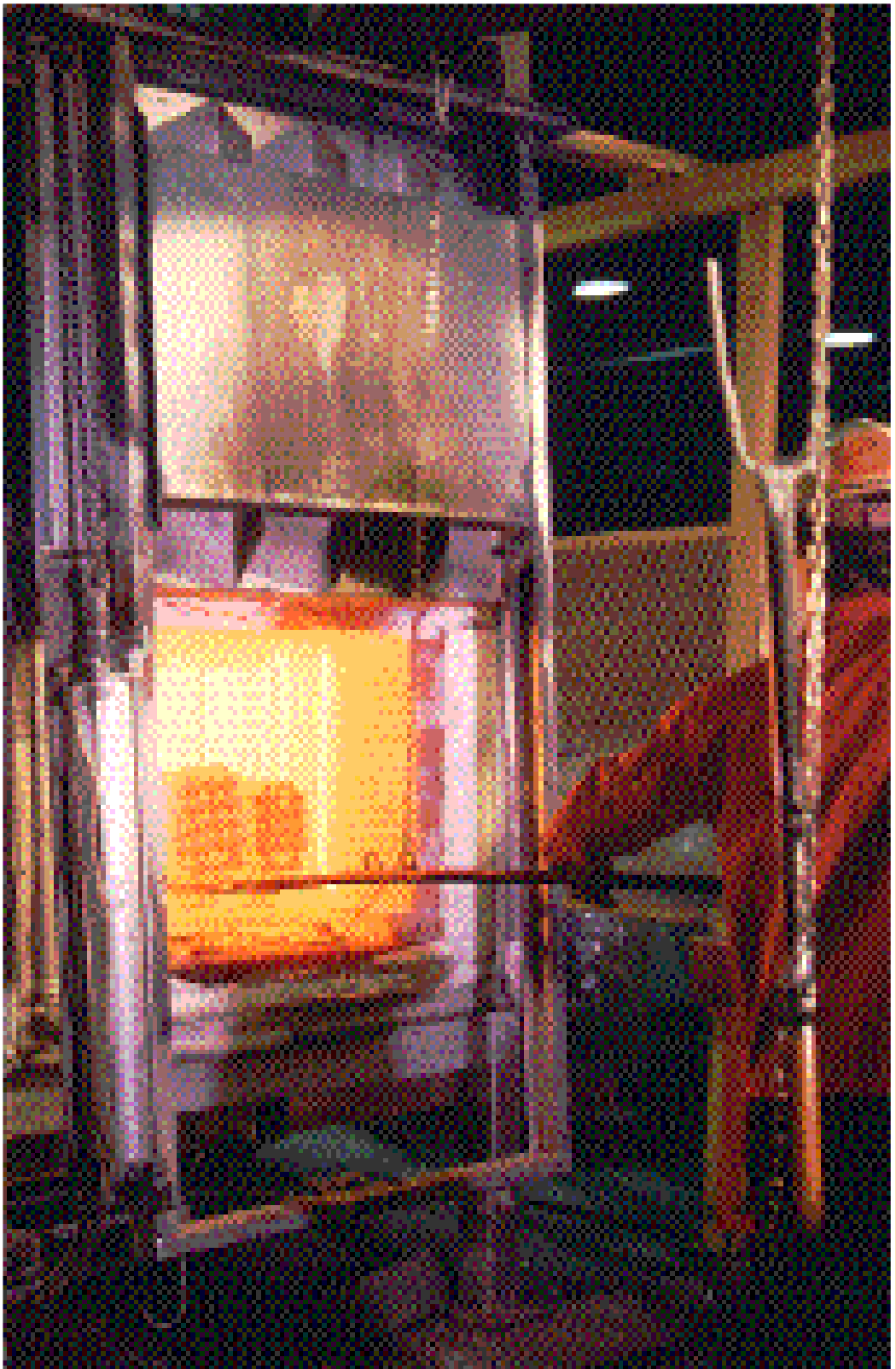

Performance

6

Temperature Dependence of Resistivity

The diagram in Fig. 26, page 63, shows that the resistivity of KANTHAL SUPER increases sharply with temperature.

Element Surface Load

The curves shown in Figs. 27 and 28 in the pages 64-65, which apply to furnaces with suspended, freely radiating KANTHAL SUPER elements show the approximate element temperature at various furnace temperatures, element surface loads and currents.

For example, at an element surface load of 14.4 W/cm^2 (92.9 W/q.in.^2) and a furnace temperature of $1300 \text{ }^\circ\text{C}$ ($2370 \text{ }^\circ\text{F}$) the element temperature of KANTHAL SUPER 1700 will be $1525 \text{ }^\circ\text{C}$ ($2780 \text{ }^\circ\text{F}$) with a current of 156 A for 6 mm \varnothing and 286 A for 9 mm \varnothing .

Wall Loading

A characteristic property of furnaces equipped with KANTHAL SUPER elements is that the surface load on the furnace walls can be much higher than with metallic elements. This is due to the high maximum operating temperature of the KANTHAL SUPER elements. Consequently, the heating-up time can be considerably reduced,

The wall loading is also dependent on how the elements are installed: along the walls or perpendicular.

Fig. 29, page 66 shows maximum recommended wall loading as a function of the furnace temperature for different element diameters and mode of installation.

6

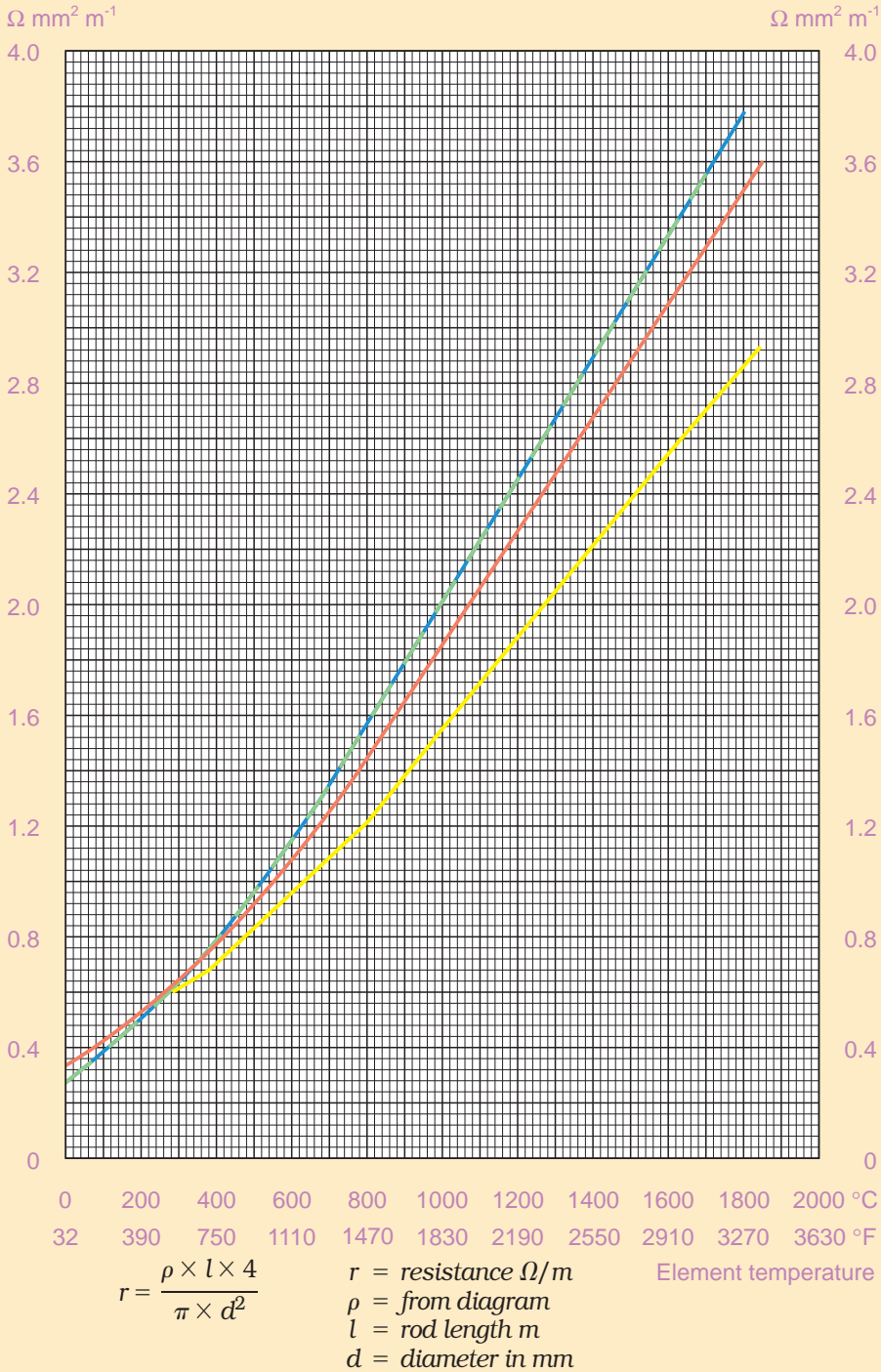

Fig. 26 Resistivity of KANTHAL SUPER 1700 (green), 1800 (blue), 1900 (red) and Excel (yellow).

6

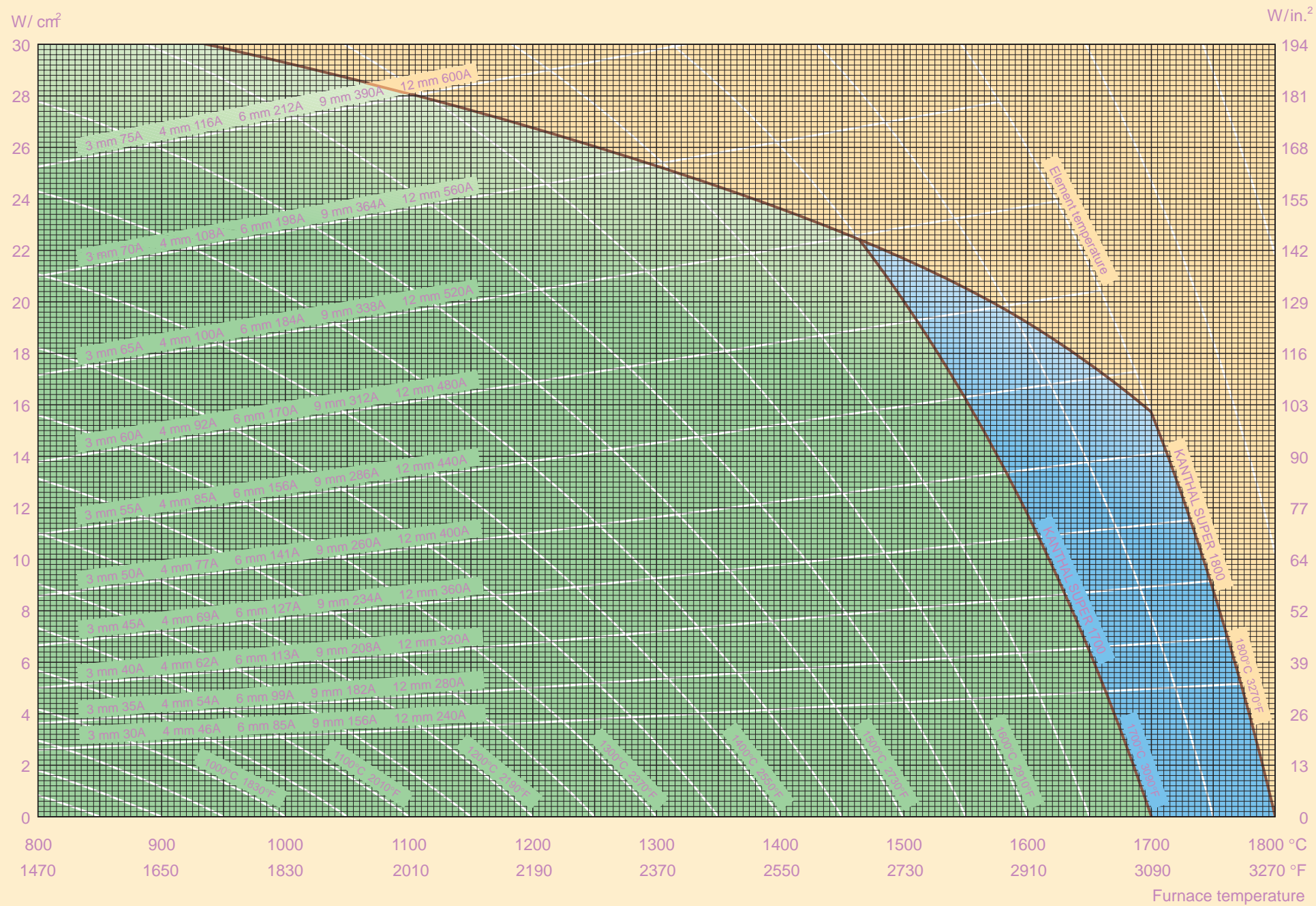

Fig. 27 Temperature — loading diagram for KANTHAL Super 1700 (green) and 1800 (blue).

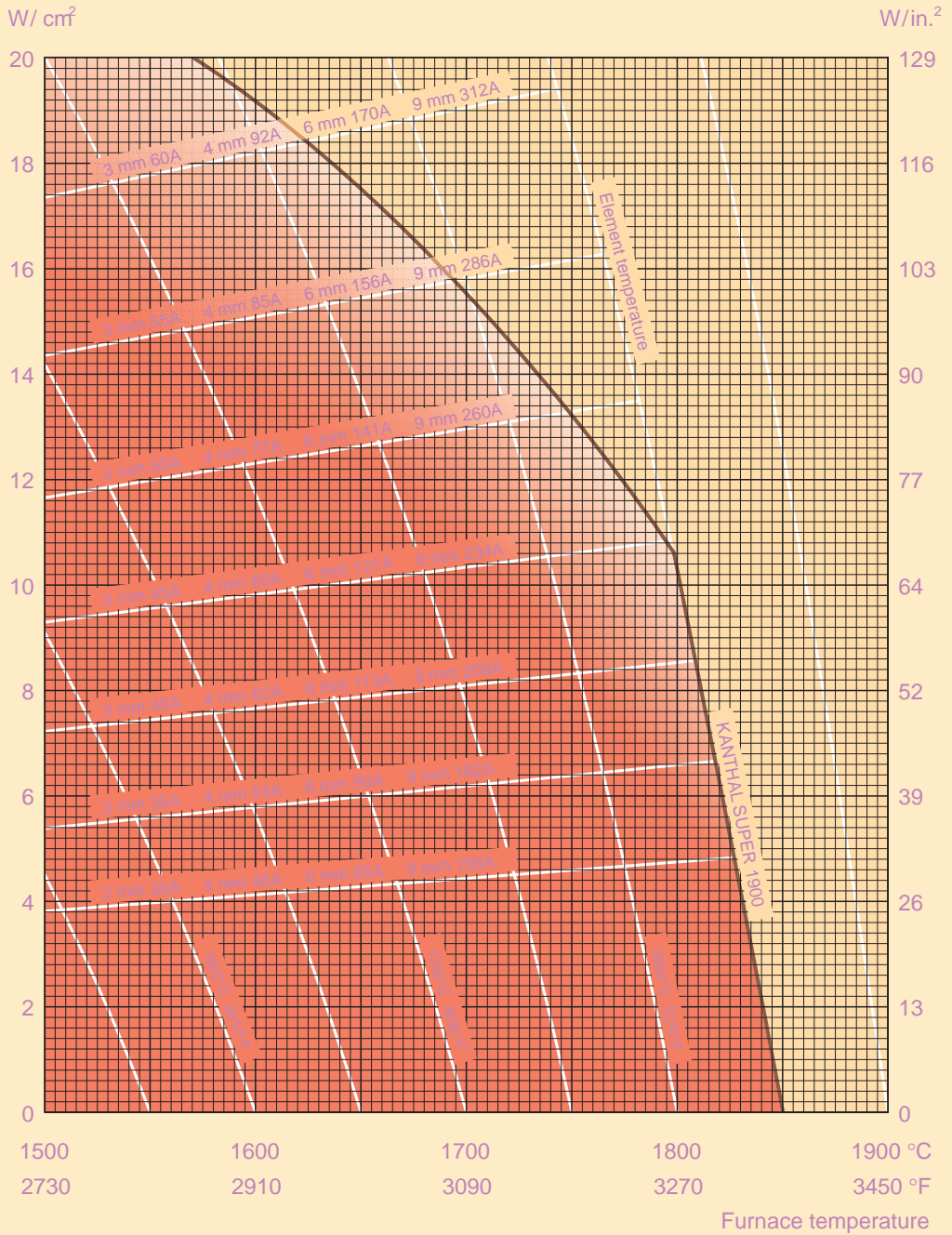

Fig. 28 Temperature — loading diagram for KANTHAL Super 1900.

6

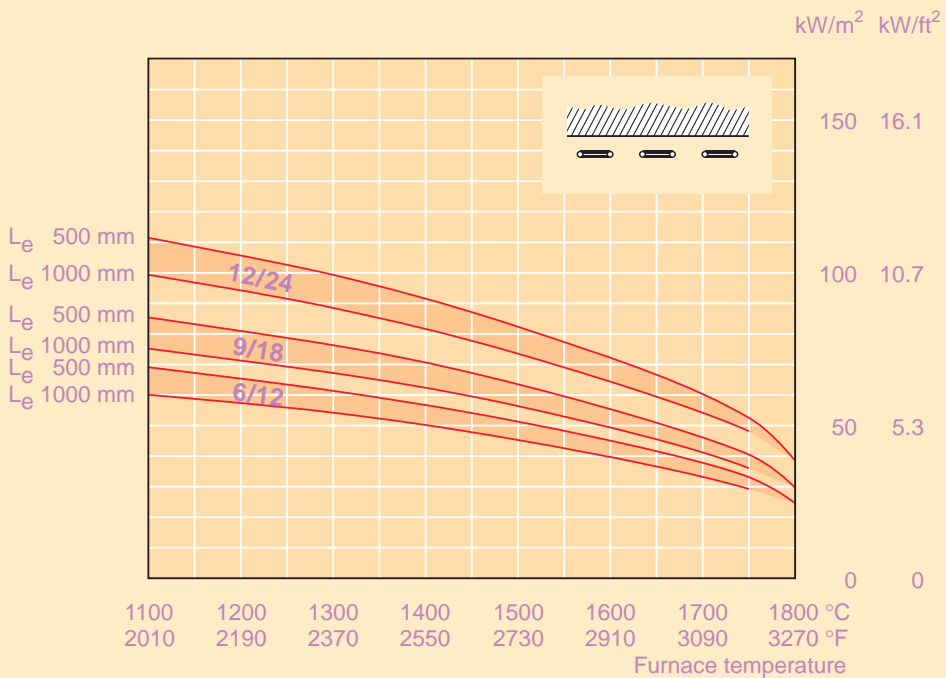
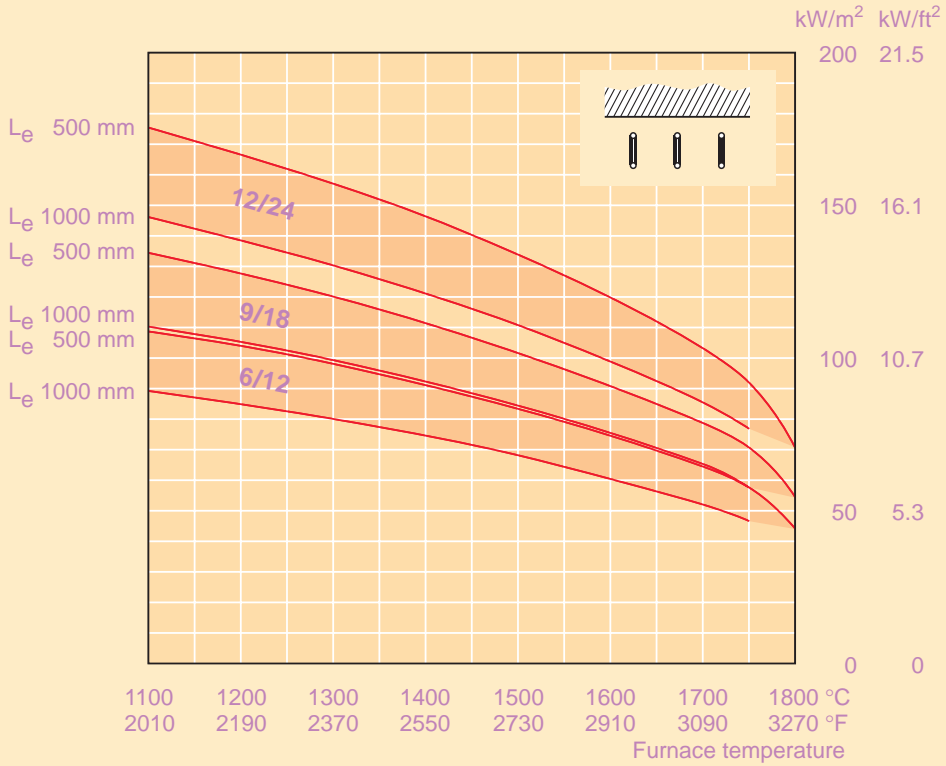

Fig. 29 Maximum recommended wall loading as a function of the furnace temperature for different element diameters and mode of installation.

Installation

7

Vertically mounted elements

The exceptional properties of KANTHAL SUPER elements can best be utilized when the elements freely radiate in the furnace chamber.

U-shaped elements fitted through the furnace roof and vertically suspended in the furnace should be considered as the standard design for a KANTHAL SUPER furnace (Fig. 31, page 56). The elements are normally placed along the side walls, but in wide furnaces it may be necessary to place elements across the width of the furnace to provide the power required (Fig. 30, page 55).

Certain furnace designs do not permit elements to be fitted through the roof. The internal height of the furnace may be such that more than one level of elements must be installed. In these cases elements with bent terminals or heating zones are available (Figs. 32 – 34, pages 57 - 58).

Horizontally mounted elements

In some types of furnaces where the roof height is low, horizontally installed KANTHAL SUPER elements may be economical and efficient.

As KANTHAL SUPER elements start to soften at temperatures around 1200 °C (2190 °F), they must generally be supported when used horizontally. This limits their maximum operating

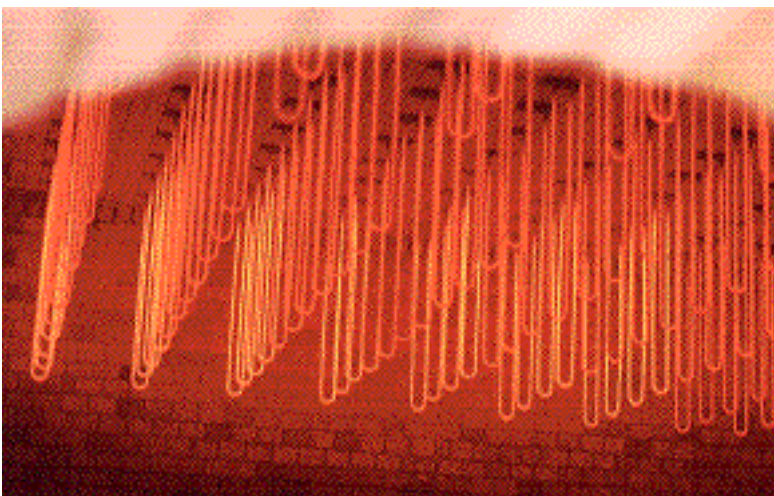

Fig. 30 Two-shank KANTHAL SUPER elements installed across the width of the furnace.

7

temperature because of possible reactions with the supporting material. If a reaction occurs between the silica layer on the element and the supporting brick, the element may adhere to the brick and fracture when cooling down. Even when suitable dense bricks of sillimanite or mullite type are used, the maximum element temperature must not exceed 1600 °C (2910 °F). Sillimanite or Mullite grains (≈ 3 mm/.12 in.) can be used on the supporting surface where applicable.

Brick lined furnaces

To facilitate the installation of KANTHAL SUPER elements in brick lined furnaces, passage bricks are used. They are installed in openings in the roof or side wall (Figs. 31 and 32, page 57). The passage bricks mounted through the roof often rests on a skew brick, which has oval holes for the elements. The passage bricks are made of heavy duty insulating firebrick of a quality matched to the furnace temperature.

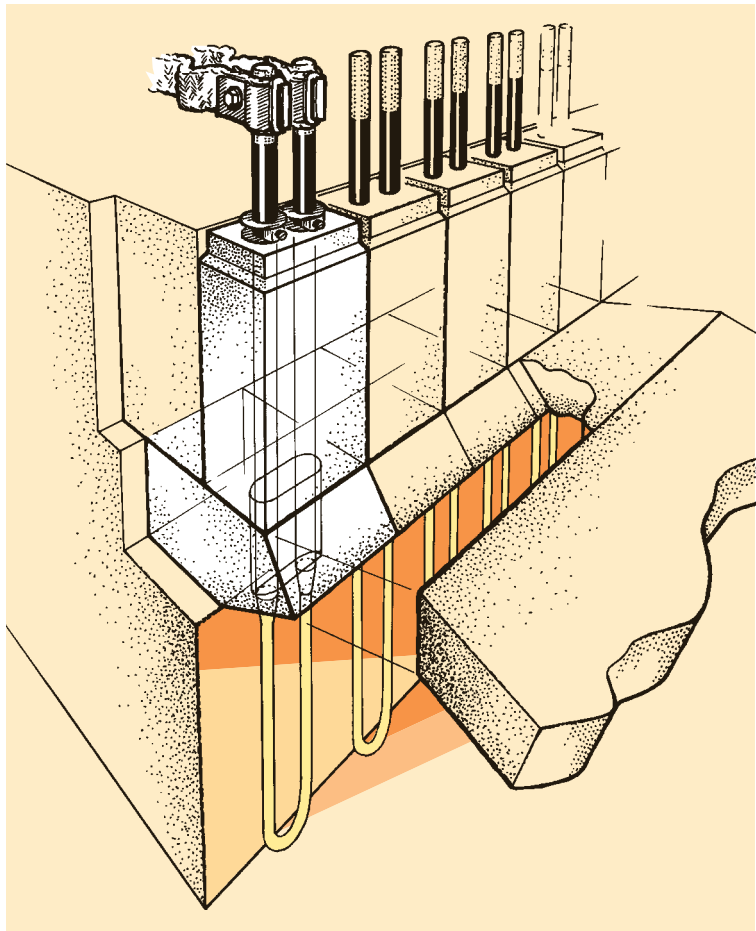

Fig. 31 KANTHAL SUPER element installation with standard passage bricks in a brick lined furnace.

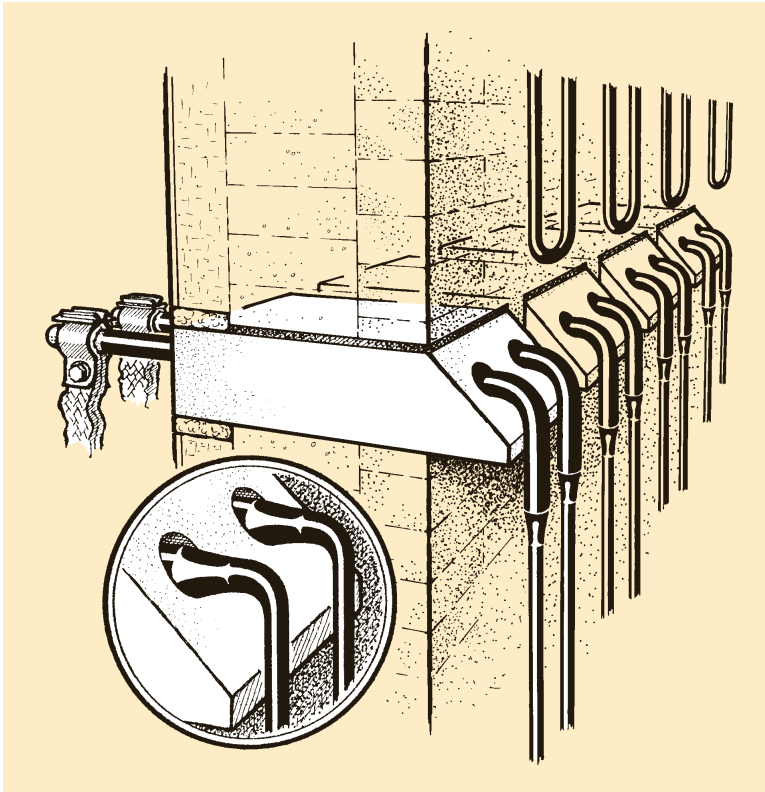

Fig. 32 KANTHAL SUPER elements, with terminals bent 90°, installed in a brick lined furnace.

Ceramic fibre lined furnaces

In fibre lined industrial furnaces, e.g. forging furnaces, if passage plugs of fibre or refractory bricks are used, then the complete element assembly also needs to be supported by the furnace roof or side walls. Figs. 33 – 36, pages 58 – 59.

In small fibre lined furnaces, e.g. laboratory furnaces, it may be sufficient to introduce the KANTHAL SUPER elements through slots in the insulation and fill the space around and between the terminals with loose ceramic fibre (Fig. 37, page 60).

In furnaces for temperatures above 1700° C (3090° F), it is important to relieve the hot face lining of the roof from the weight of the element assembly. It is recommended to use a divided passage plug of ceramic fibre (Fig. 38, page 61) or a passage plug supported by the cold side of the roof (Fig. 39, page 61).

7

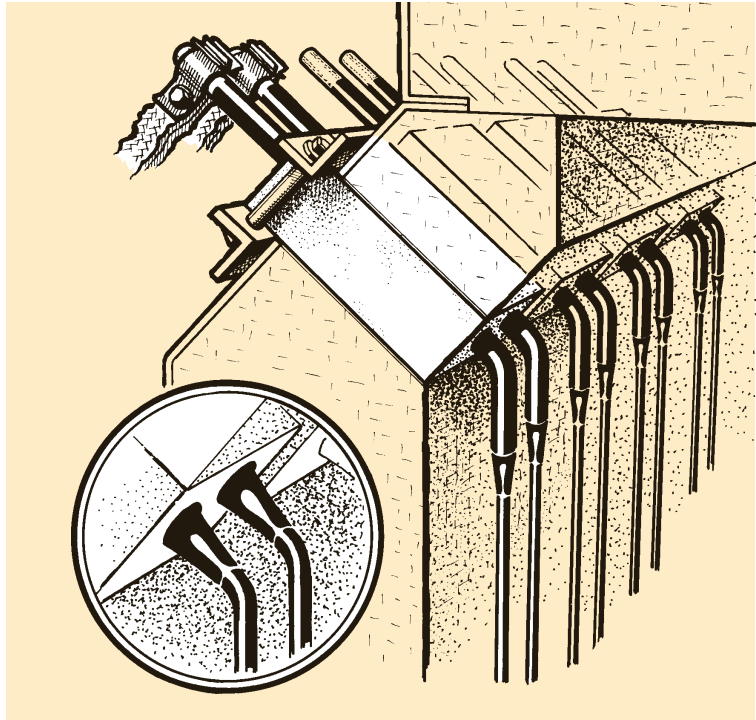

Fig. 33 KANTHAL SUPER elements, with terminals bent 45°, installed in ceramic fibre insulated furnace.

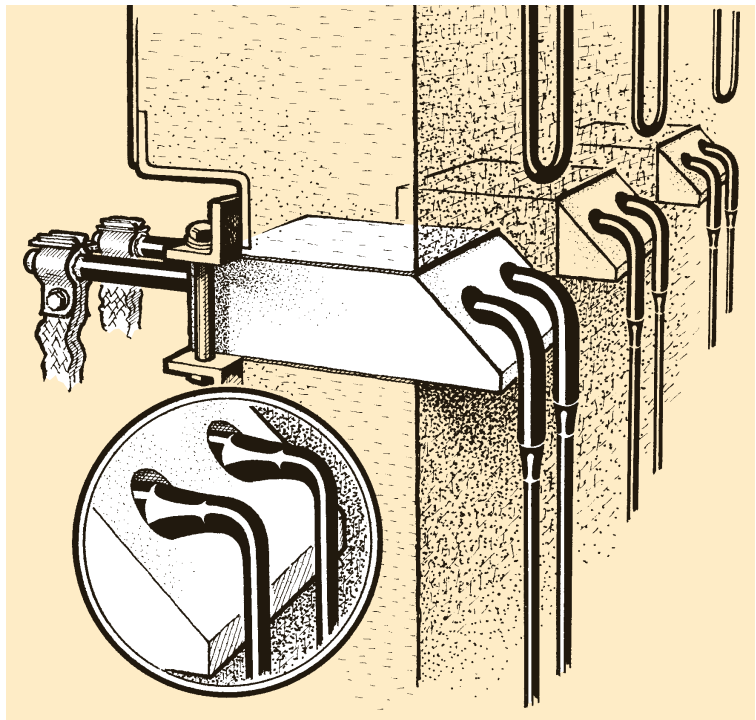

Fig. 34 KANTHAL SUPER elements, with terminals bent 90°, installed through a furnace wall in a fibre lined furnace.

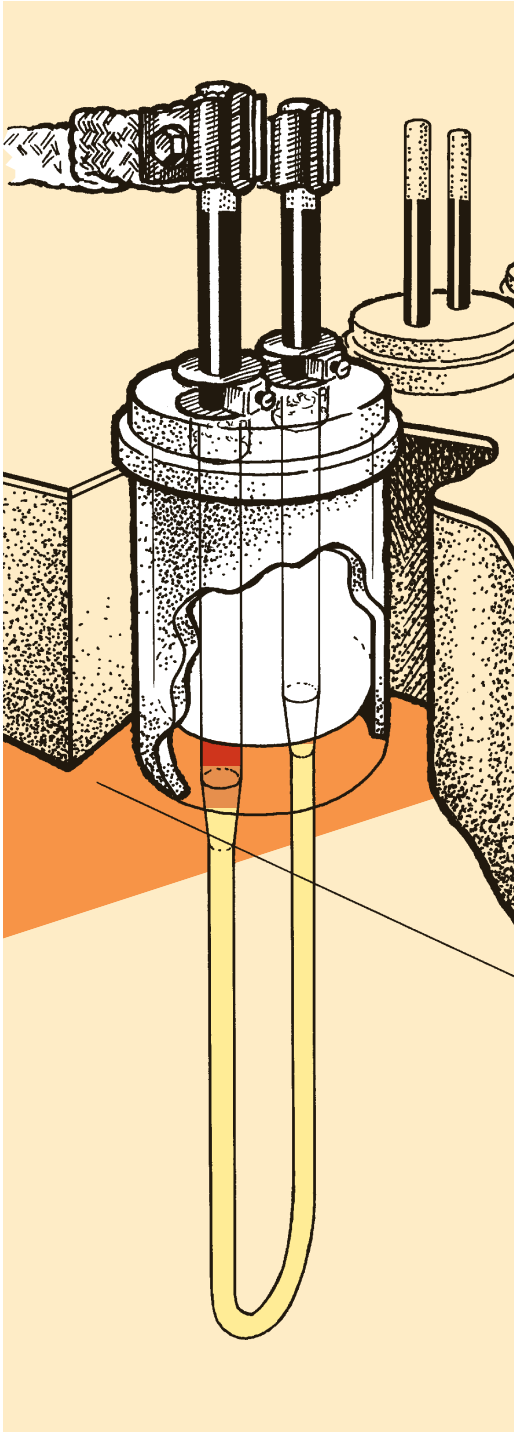

Fig. 35 KANTHAL SUPER elements in ceramic fibre lined furnaces. The passage plugs with a flange are made of ceramic fibre and fitted into ceramic fibre sleeves.

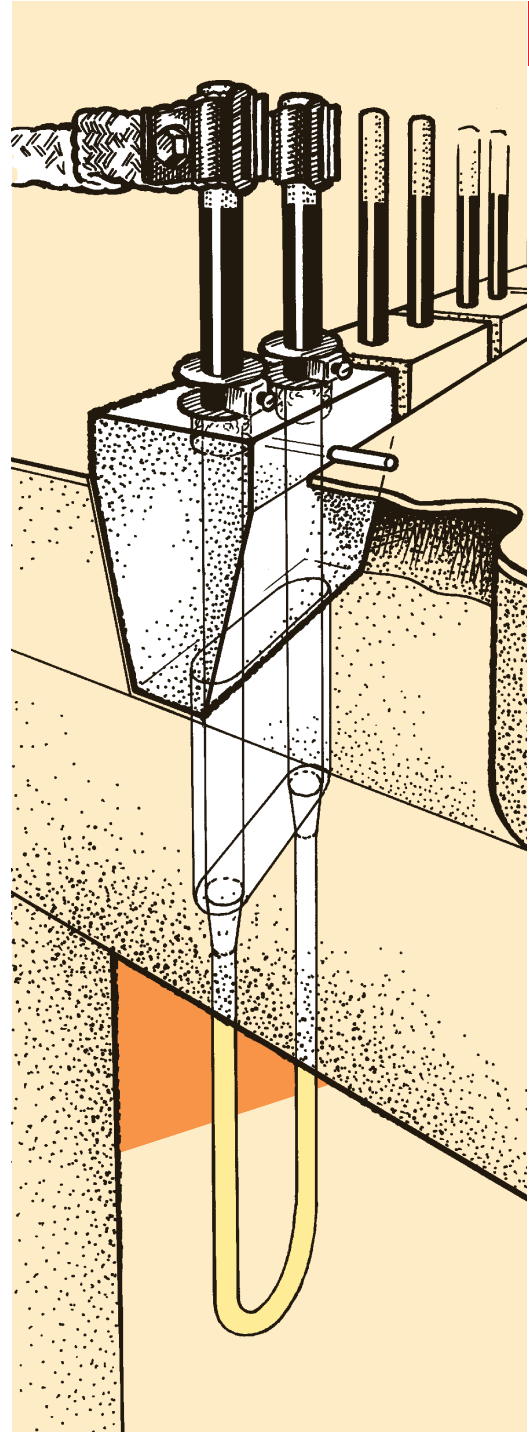

Fig. 36 KANTHAL SUPER elements in ceramic fibre lined furnaces. The passage plugs made of a heavy duty insulating firebrick are suspended by the cold side of the roof.

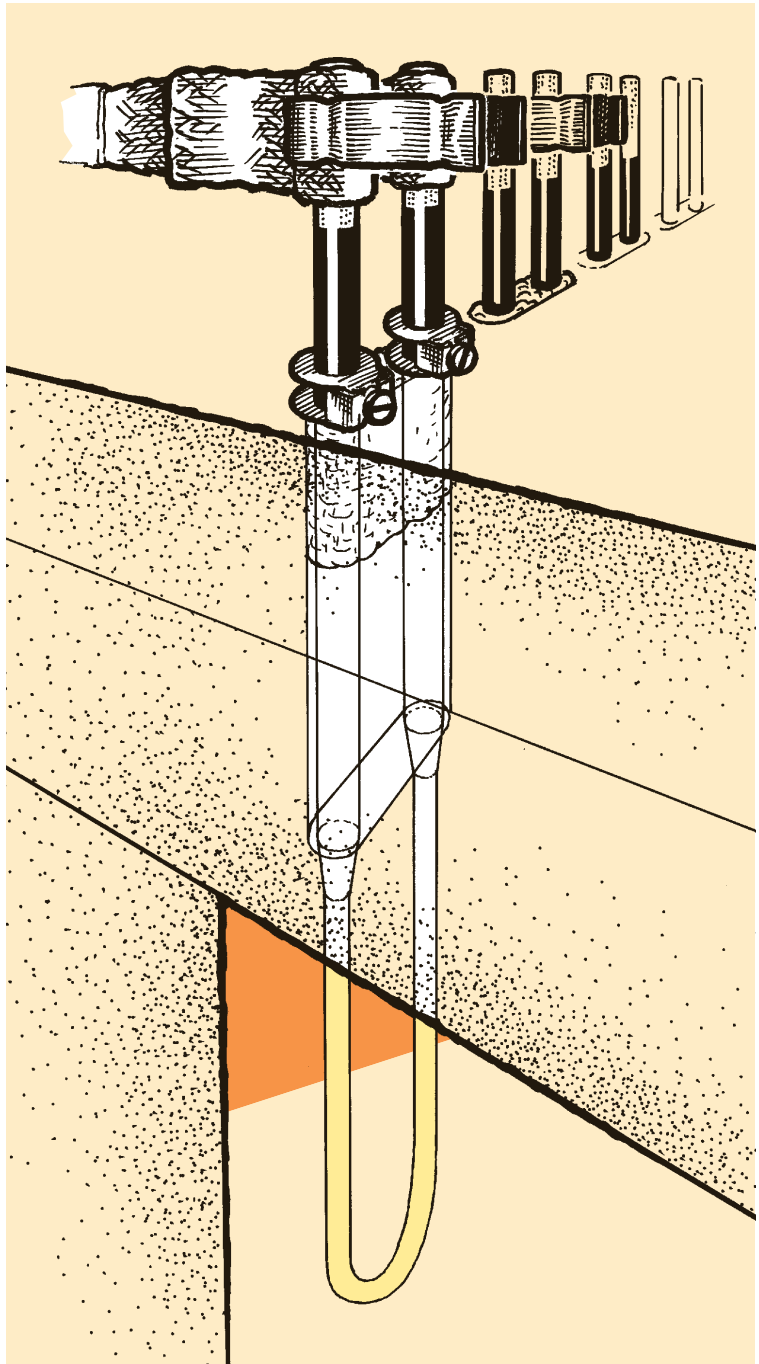

Fig. 37 KANTHAL SUPER elements in ceramic fibre lined furnaces installed through oval slots in the roof.

The weight of the element sets is carried by the outer lining. Especially useful in furnaces for very high temperatures.

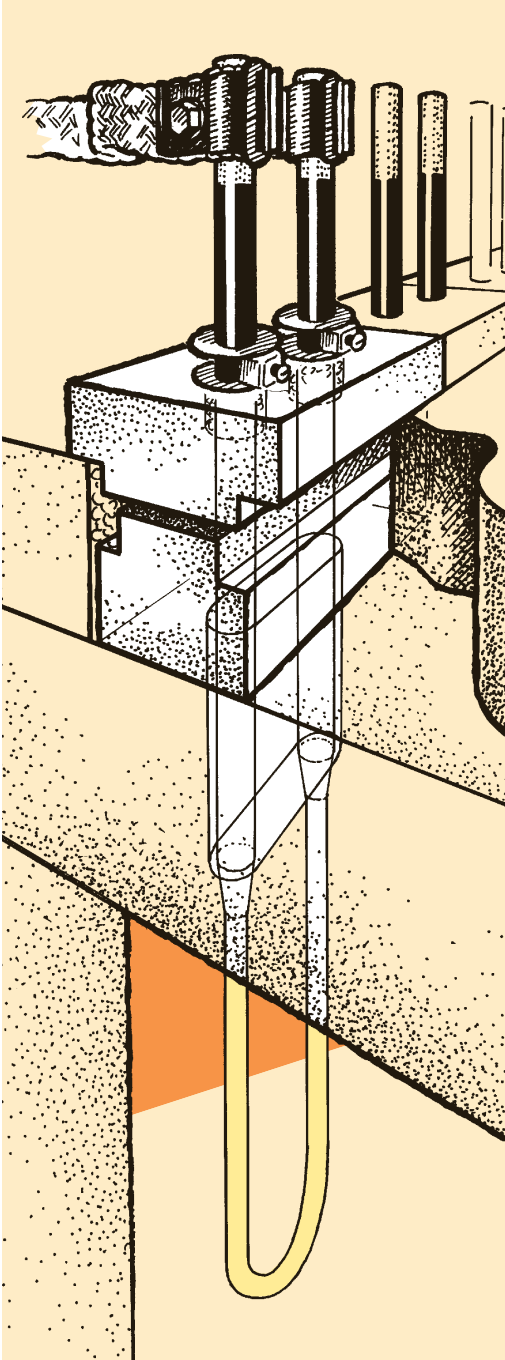

Fig. 38 KANTHAL SUPER elements in ceramic fibre lined furnaces. The passage plugs are divided in two pieces.

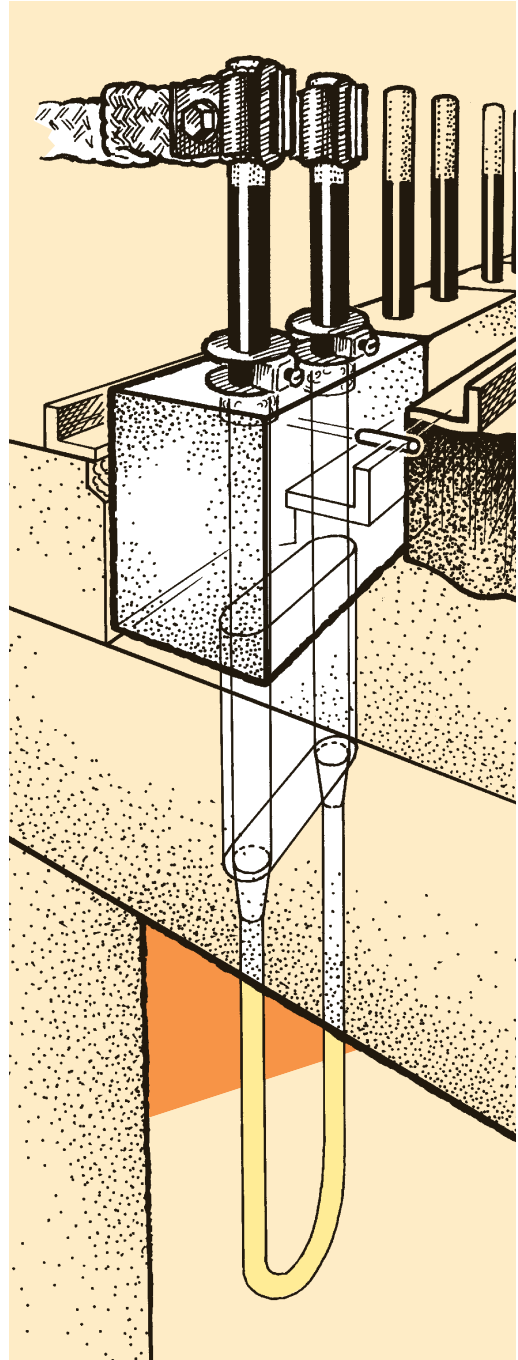

Fig. 39 KANTHAL SUPER elements in ceramic fibre lined furnaces. The passage plugs and elements are supported by the cold side of the roof.

Element holders and anchor systems

Single-shank holders

Single-shank holders can be used for all kinds of KANTHAL SUPER qualities. It is essential that the terminals are able to move freely and independently of each other, otherwise mechanical stresses may cause the element to break. This is important at very high temperatures.

Two-shank holders

Two-shank holders are used when the elements need to be anchored to the passage brick.



Fig. 40 Single-shank holders.

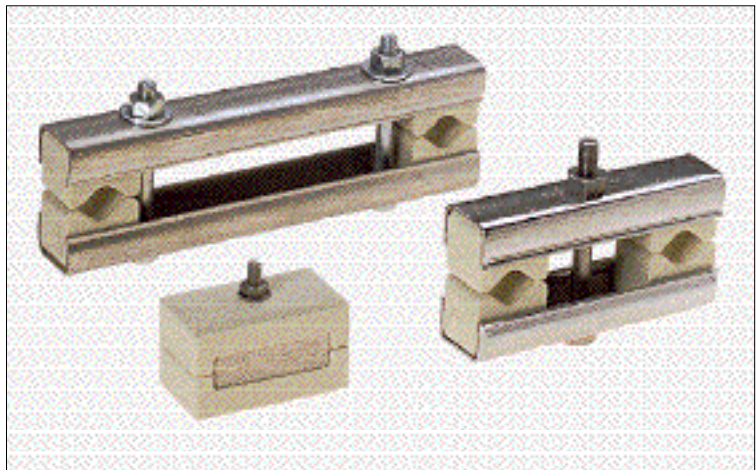

Fig. 41 Two-shank holders.

Standard anchor system

When KANTHAL SUPER elements are used in an air atmosphere the standard anchor system is recommended in brick lined furnaces.

A fastening yoke holds the anchor pin, which is secured in the passage brick by a locking pin.

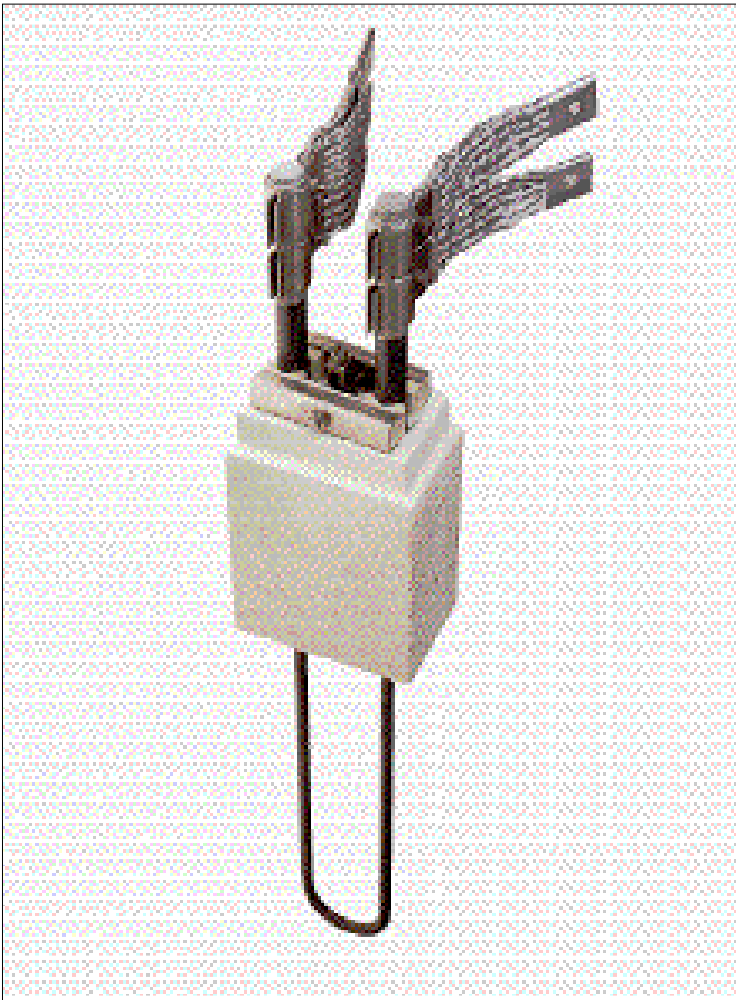

Fig. 42 Element holder and anchor system — Standard design.

7

“Air cooled” anchor system

By using the “air cooled” design it is possible to blow cooling air down along the terminals. In furnaces where impurities in the form of dust or fumes occur, e.g. glass melting furnaces, it is essential that such substances be prevented from depositing and condensing in the holes of the passage bricks; otherwise, corrosion may occur on the element terminals. The element may also be jammed in the hole, thus preventing free movement and possibly leading to element breakage. This is particularly important in glass melting furnaces, since glass fumes readily condense, resulting in damage to KANTHAL SUPER elements. Normal overpressure of the air is 200-700 Pa at a flow rate of 3-4 litres/minute for each element.



Fig. 43 Element holder and anchor system — Air cooled design.

Sealed anchor system

KANTHAL SUPER elements are often used in furnaces with controlled atmospheres. When the elements operate directly in the atmosphere, it is essential that the terminals be sealed. A lead-through, which is sealed and bolted to the shell of the furnace, is shown in the figure below.



Fig. 44 Element holder and anchor system — Sealed design.

7

Contacts

Each contact consists of a double-folded aluminium braid, which is secured around the aluminized end of the terminal by means of a spring or screw clamp.

The busbar end of the braid is reinforced with an aluminium sleeve. The standard sizes and types available are shown on pages 111 – 118, Appendix 1.

It is essential that **no mechanical stresses should be transmitted to the elements through the aluminium braids**. The length of the braid should therefore be longer than the straight distance between the element and the busbar. When tightening the bolts at the element terminal, it is important that the terminal should not be twisted or bent.

In order to avoid breakage of the elements, **direct connection of element to element is not recommended**. They should be connected to busbars or with individual braids which are bolted together. See photo below.

The aluminium braids should not be connected to copper busbars. Stainless steel screws and aluminium busbars are recommended.

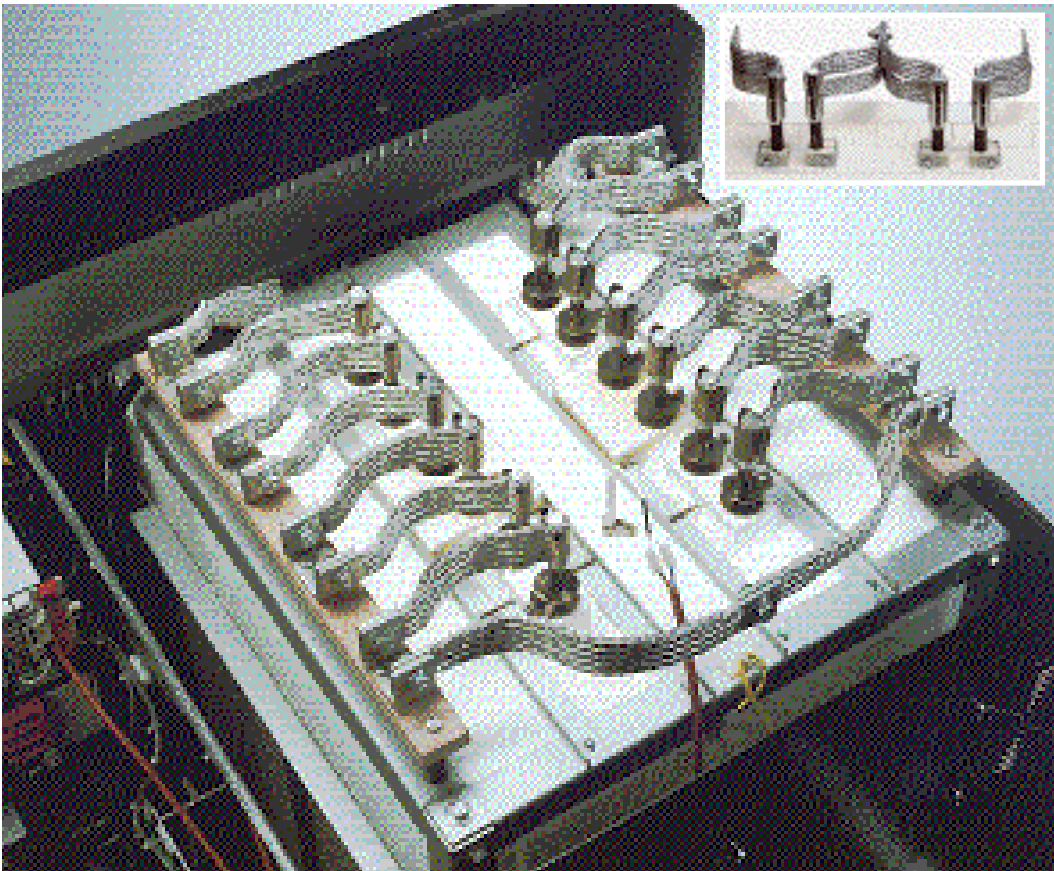

Fig. 45 KANTHAL SUPER elements connected to busbars.

When using KANTHAL SUPER elements the current is high. Consequently, the transition resistance between contact and terminal must be kept low. The voltage drop across the contact should not exceed 0.01 V. Aluminium oxidizes easily, and the alumina layer built up on the surface is a good insulator. Furthermore, the creep strength of aluminium is low and **the temperature at the contacts should not exceed 300° C (570 °F)**. When screw clamps are used, it is essential that the bolts be fully tightened.

The contacts are designed for a continuous current of:

Element size:	3/6	4/9	6/12	9/18	12/24
Current (A)	75	115	200	365	560

In order to avoid overheating of the contacts due to radiation and conduction through the terminals, the minimum length of the terminal protruding from the passage brick, L_c , should be as shown in the table on page 90.

If a contact becomes damaged, it should be replaced. If the aluminized layer on the terminal is damaged, it should be removed by careful grinding with emery cloth. Then a new contact should be fitted.

An excessive temperature in the busbar housing may cause overheating of the contacts. This may be due to insufficient ventilation. If natural convection is not sufficient, forced convection is recommended.

A common cause of overheating of the contacts is poor sealing between the terminals and the passage brick, and between the passage brick and the roof, resulting in a “chimney” effect. This not only causes overheating of the contacts but also increases the temperature of the terminal, which leads to excessive heat generation in the roof.

Sealing, therefore, must be carefully carried out using high duty ceramic fibre. In the standard passage bricks there are recesses around the terminals as well as a shoulder around the top to facilitate efficient sealing.

Should overheating of the contacts be caused by poor insulation of the roof, forced air cooling of the contacts will be necessary if it is not possible to improve the insulation.

Fixed contacts Kanthal Super

Kanthal has been developing a fixed contact as an alternative to the standard bolted on contacts. These can be utilized, where the temperature of different reasons is high.

The fixed contact design, for terminal dimensions 4-24 mm, consists of a metallic sleeve soldered to the terminal end. The other end is squeezed around the aluminum braid, which has a cable clip at the other end.

This contact design can withstand 400°C on the sleeve.



Assembling of KANTHAL SUPER element

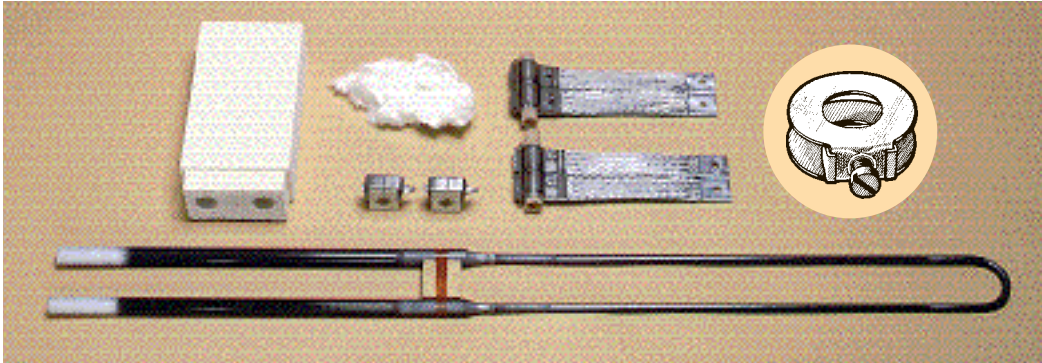

1. KANTHAL SUPER elements should not be unpacked until the furnace and the busbars are ready. Pages 80 - 81 show the practice employed when assembling vertically suspended KANTHAL SUPER elements with passage bricks.



6. When determining the position of the element holder, it is of the utmost importance to ensure that the tapered transition between terminal and heating zone comes fully below the hot face of the furnace lining (10) (g Fig. 47, page 70). If not, there is a risk that the part of the heating zone which is inside the lining may become overheated.

When connecting the installed elements, the aluminium braids should first be bolted to the elements and then to the busbars.

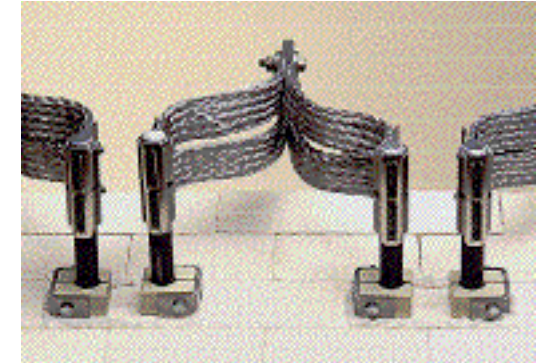

9. When fastening the contact bolts the elements must not be bent or twisted.



2. When unpacking, care should be taken to avoid any bending or twisting.



3. The element is placed horizontally on a table and the terminals are carefully inserted in the holes in the passage brick ensuring that the correct length of terminals are protruding from the top of the brick.



4. After packing heavy-duty ceramic fibre loosely into the recesses of the terminal holes

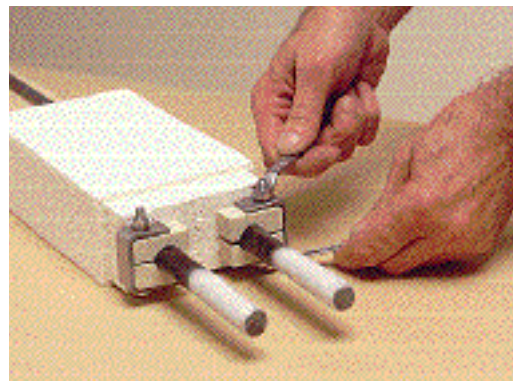

5. ...single- or two-shank element holders should be fixed to the terminals.



7 Before inserting the element assembly ...



8. ...it is necessary to check the size of the corresponding holes in the roof.

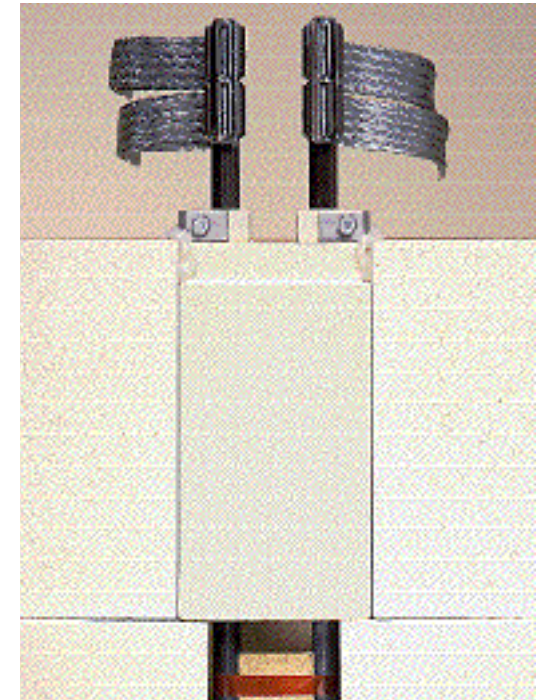

10. **Finally, check that the installed elements can move freely !**

7

Distance to wall

It is important that the distance between wall and heating zone of the element is large enough to avoid contact. In the case of long elements at high temperatures, electro-magnetic forces and bad centering when installing the elements may cause the elements to come in contact with the walls, causing damage.

The minimum distance, e , between the heating zone of the element and the furnace walls depends on the length of the element. See Fig. 47, page 83.

When installed **along the wall** it is:

$$\text{For } L_e < 1000 \text{ mm (39.4 in.)}; e = L_e/20$$

$$\text{For } L_e < 300 \text{ mm}; e = \text{min. } 15 \text{ mm (0.6 in.)}$$

$$\text{For } L_e > 1000 \text{ mm (39.4 in.)}; e = \text{min. } 50 \text{ mm (1.97 in.)}$$

When installed **perpendicular to the wall**, the deformation due to the electro-magnetic forces must also be considered. The reason is that the deformation causes reduction of the distance between part of the heating zone and the wall. After calculating the magnitude of deformation (Fig. 49), the distance E can be calculated and e is estimated in the same way as for elements installed parallel to the wall.

$$E_{\min} = e + \frac{A - a}{2}$$

Distance to bottom

In order to prevent the elements from coming into contact with any material deposited on the bottom of the furnace and to compensate for the elongation of the elements at high temperatures, the recommended vertical distance h between the element bend and the furnace floor should be at least:

$$h \geq \frac{L_e}{20}; \text{ min. } 10 \text{ mm}$$

Distance between elements

Minimum distances, b , between adjacent elements are given in fig. 48, page 83.

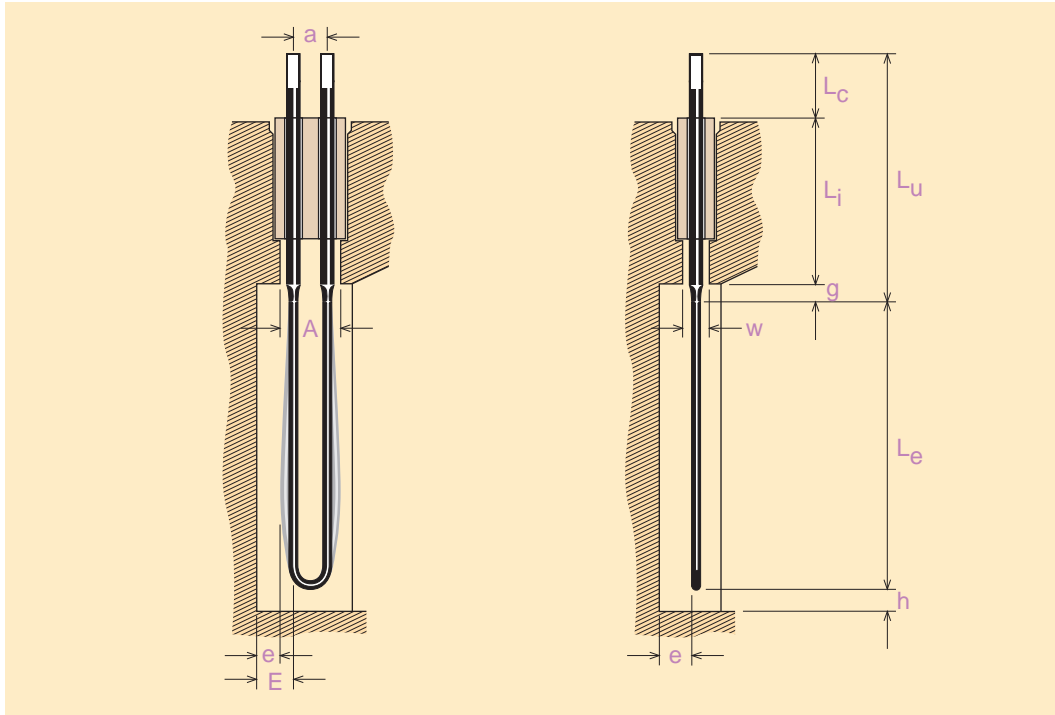

Fig. 47 Installation parameters.

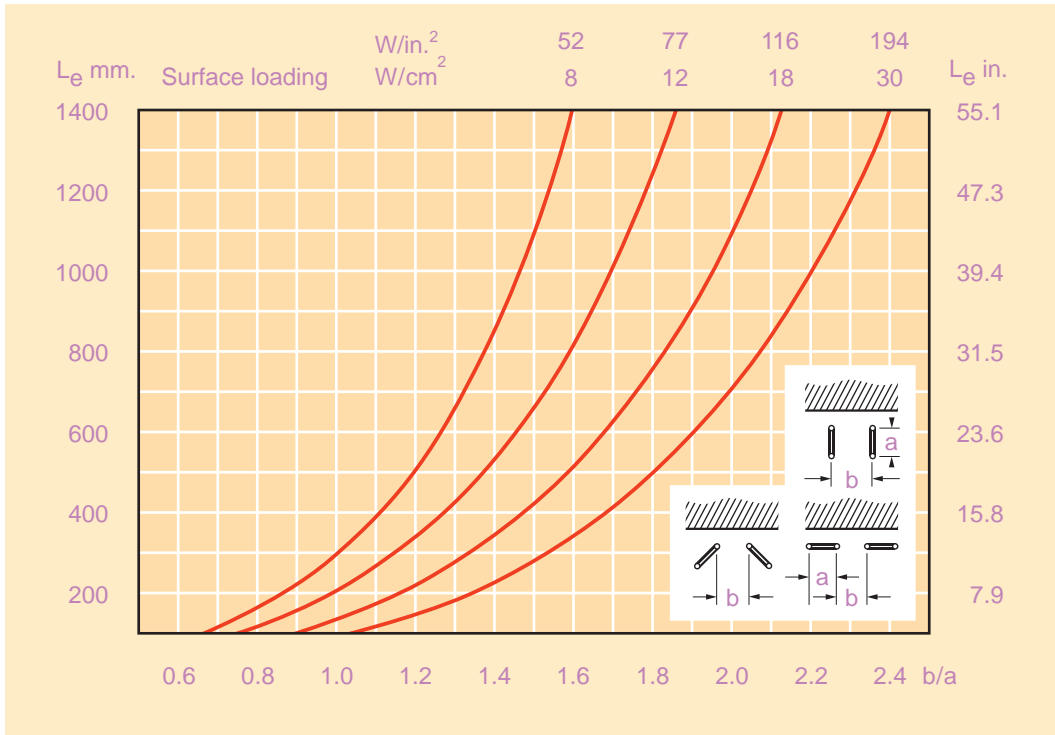

Fig. 48 Necessary distances, b , to counteract the effect of the electro-magnetic force on KANTHAL SUPER elements.

7

Element size:	3/6	4/9	6/12	9/18	12/24
Hole dia. of pass. brick	9 mm 0.35 in.	12 0.5	15 0.6	23 0.9	30 1.2
Recommended min. width of opening in skew brick, w	15 mm 0.6 in.	20 0.8	25 1	30 1.2	40 1.6

Table 7 Important Installation parameters for passage brick and skew brick.

The minimum length of opening A is calculated according to the diagram in Fig. 49.

Fig. 49 Deformation of KANTHAL SUPER elements due to electro-magnetic forces. Valid for all sizes – 3/6, 4/9, 6/12, 9/18 and 12/24.

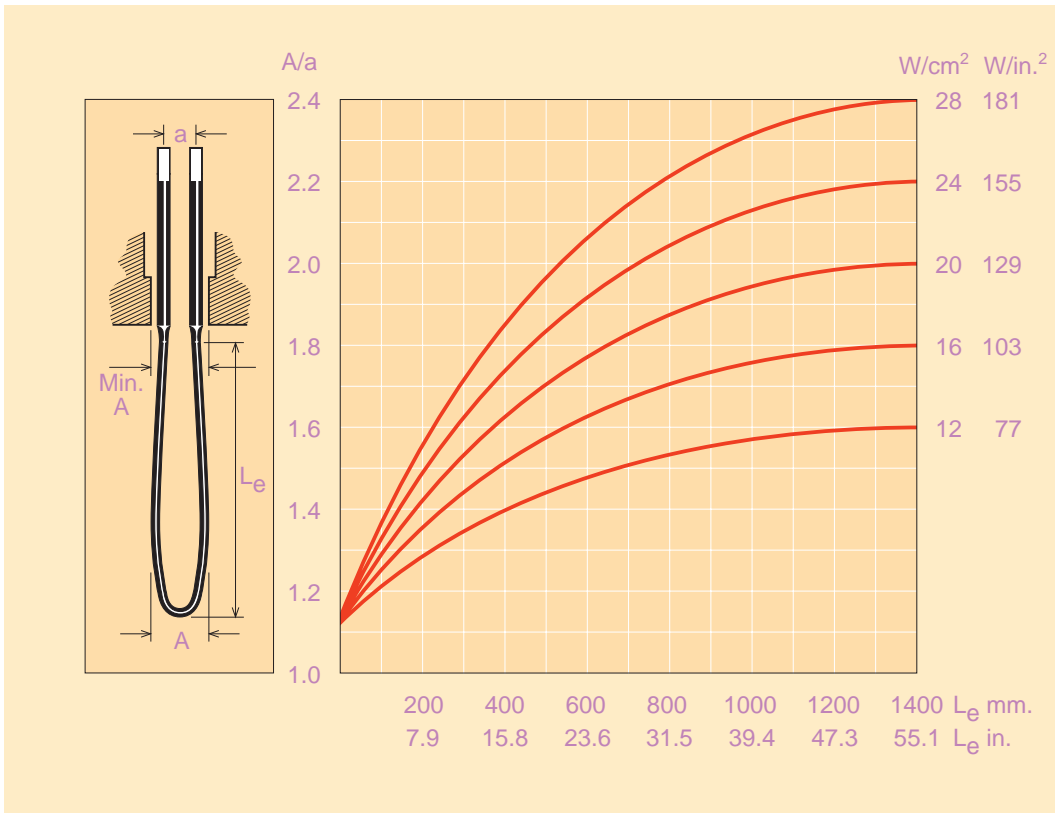

Assembling of SUPERTHAL furnaces.

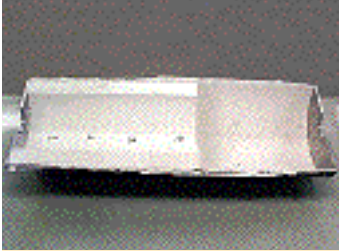

1. Place the steel casing on a table and apply a fibre felt onto the inside of the casing. Adjust the back-up insulation if needed and put it in place. Mark carefully the location of the element terminals and drill the holes to 20 – 23 mm through the fibre and casing.



2. With multizone vertical furnaces intermediate supports are recommended, which could be secured to the back-up insulation with ceramic tubes.



3. When the element modules are installed the casing is put on supports with room for the protruding terminals. **Be very careful during assembling to avoid mechanical stress on the terminals.**

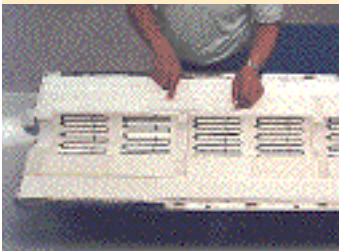

4. Before the two half-shells are put together apply insulating ceramic fibre felt onto the module ends to improve the insulation.



5. After the two half-shells are bolted together, raise the furnace to an erect position. Seal around the terminals with ceramic fibre wool. Do not pack too tight. Be careful not to create stress in the terminals.



6. Mark the location for the terminal blocks. Drill and bolt them to the casing.



7. Before connecting the braids they have to be preformed to eliminate any stress on the terminals. Very important — When the spring clips are applied hold the terminal with the other hand **to avoid any bending force on the terminal.**



8. The furnace is wired for three zones. Note the slack in the braids.

Fig. 50 Assembling and installation of a SUPERTHAL furnace.

7

Elements in radiant tubes

Although KANTHAL SUPER elements can operate directly in most atmospheres, it is sometimes advantageous to insert them in radiant tubes. These protect the elements when maintenance is performed inside the furnace.

Element replacement is simplified as no special precautions have to be taken with the furnace atmosphere when an element needs to be replaced.

Complete tube system

The development of KANTHAL Extruded APM tubes enables us to offer a complete heating system, element assembly and radiant tube. KANTHAL Extruded APM tubes have an excellent form stability up to a furnace temperature of 1250 °C (2280 °F), and a non-flaking alumina oxide layer. They are available in various standard dimensions. For KANTHAL SUPER 9/18 and 12/24 elements suitable dimensions are:

For horizontal mounting
OD/ID 146/134 mm
(5.8/5.3 in.)
and 154/142 mm
(6.1/5.6 in.).

For vertical mounting
OD/ID 154/142 mm
(6.1/5.6 in.)
and 164/152 mm
(6.5/6.0 in.).

Example:

2 pcs KANTHAL SUPER 1700 12/24 elements in a vertical APM tube with dimension 198/180 mm (7.8/7.1 in.).

At furnace temperature 900 °C (1650 °F) a power of 40 kW/m (12 kW/ft.) heating zone length is possible.

At 1200 °C (2190 °F) furnace temperature the maximum power is 25 kW/m. (7.6 kW/ft.).

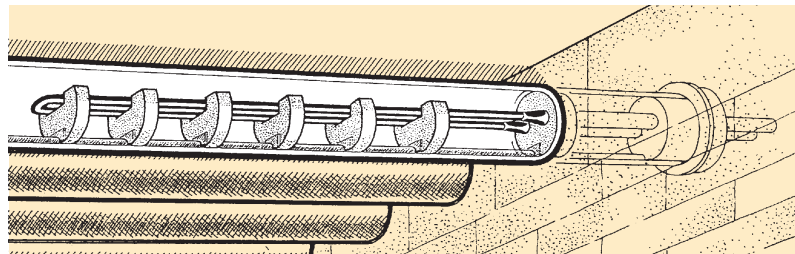
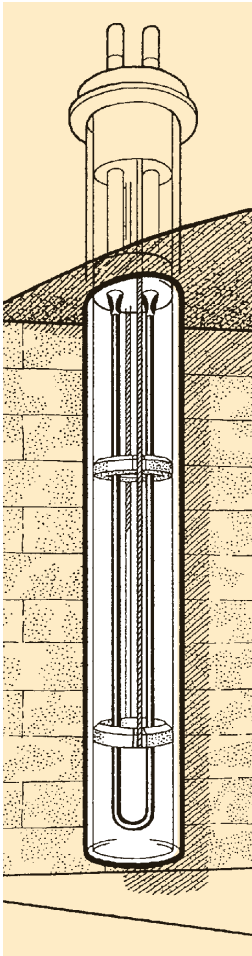

Fig. 51 KANTHAL SUPER elements in horizontally and vertically mounted radiant tubes.

Calculations

Symbols

The following symbols are used:

- L_u = Terminal length, mm; in.
- L_e = Heating zone length, mm; in.
- a = Distance between shanks, mm; in.
- B = Intermediate heating zone length, mm; in.
- d = Heating zone diameter, mm
- D = Terminal diameter, mm
- L_H = Total rod length of heating zone, m; in.
- L_T = Total rod length of terminals, m; in.
- P = Total power, kW
- P_e = Power per element, W
- $P_{e \text{ tab}}$ = Power per element from table, W (See pages 34-48)
- U = Connecting voltage per group, V
- U_e = Voltage per element, V
- I = Current, A
- R_t = Hot resistance per element, Ω
- r_e = Heating zone resistance, Ω/m ; $\Omega/in.$
- r_u = Terminal resistance, Ω/m ; $\Omega/in.$
- T_e = Temperature of the heating zone, $^{\circ}C$; $^{\circ}F$
- T_f = Furnace temperature, $^{\circ}C$; $^{\circ}F$
- p = Surface load on the heating zone, W/cm^2 ; $W/in.^2$
- p_{tab} = Table value of surface load on the heating zone, W/cm^2 ; $W/in.^2$ (See pages 34 - 48)
- n = Number of elements
- S = Number of shanks
- () = Imperial Units

8

Furnace power

The design and size of the furnace needed are generally determined by the charge.

The power of the furnace can be calculated in two basic ways:

1. According to diagram (Fig. 52)
2. According to the actual charge and heat losses.

The most accurate method is according to the actual charge and heat losses.

The power needed according to the actual charge is determined as follows:

$$P_c = G \times C \quad \dots 1$$

P_c = Power needed for charge, kW

G = Weight of charge, kg

C = Heat storage of charge at temperature, kWh/kg

Example: $G = 60 \text{ kg}$, $C = 2.5 \text{ kWh/kg}$: $P_c = 60 \times 2.5 = 150 \text{ kW}$

The efficiency of electric furnaces varies normally between 0.6 and 0.9.

Generally it is sufficient to make an allowance of 70 - 80 % for losses and control intermittence in order to obtain a fully adequate installed power.

The furnace power P , is then determined:

$$P = \frac{P_c}{\eta} \quad \dots 2$$

η = efficiency and allowance for losses and control intermittence

$$\eta = 0.75 \times 0.8 = 0.6$$

Example: $P = \frac{150}{0.6} = 250 \text{ kW}$

When calculating a laboratory furnace or some other multi-purpose furnace, when the charge is not entirely known, the power should be calculated according to the diagram or based on experience.

In order to check the feasibility of:

Installed power

Accessible area for element installation

Element dimension

Element location

recommendations shown in Fig. 52, page 76 should be followed.

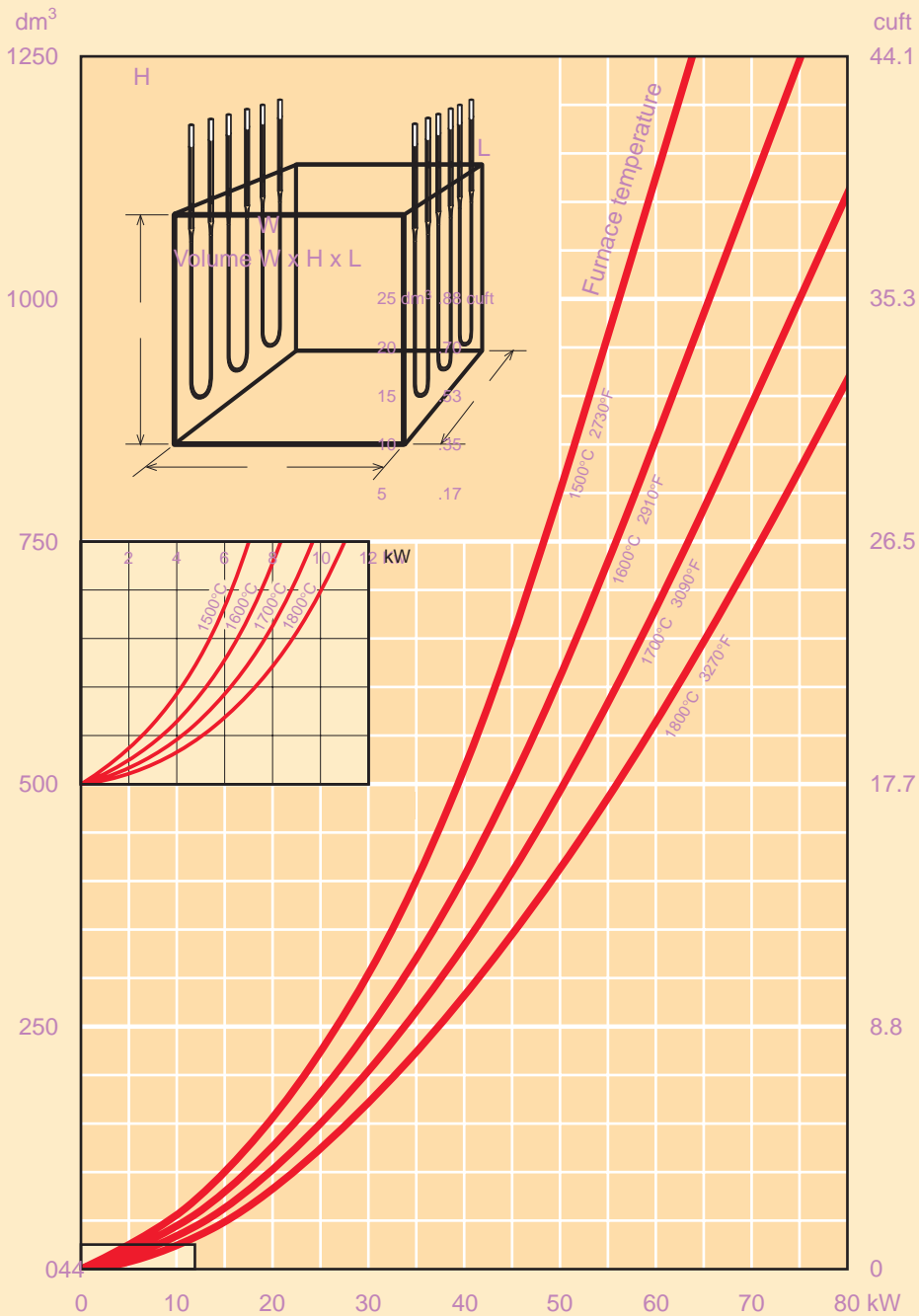

Fig. 52 The approximate power at a given chamber volume for a ceramic fibre lined furnace. For a brick lined furnace the power is normally about 25 % higher.

8

Element selection

Element quality and dimensions have to be selected and calculation of the number of elements has to be made.

The furnace data provided are:

- Size (W x H x L)
- Type of insulation and thickness
- Operating temperature
- Total power
- Element location
- Line voltage
- Control and power supply

Terminal length

When determining the terminal length L_u , it is necessary to know the distance from the hot face of the furnace roof to the cold face of the passage brick, L_i or passage plug.

The tapered part of the terminal must come fully below the hot face of the lining as indicated in Fig. 47, page 70.

The following table gives information about the length of taper g , and the minimum length of terminal protruding above the passage brick $L_c min.$

Element size:	3/6		4/9		6/12		9/18		12/24	
	mm	in.	mm	in.	mm	in.	mm	in.	mm	in.
Length of taper g	15	0.6	15	0.6	25	1.0	30	1.2	40	1.6
$L_c min.*$	50	2	50	2	75	3	125	5	150	6

* For holders of "air cooled" and sealed design $L_c min.$ for 6/12 is 100 mm (4 in.) and 9/18 140 mm (5.5 in.).

The total minimum terminal length is calculated according to the formula:

$$L_u min. = L_i + L_c min. + g \tag{...3}$$

Heating zone length

The following must be taken into consideration:

The internal height of the furnace where the elements are located, H .

The length of the tapered part, g .

A safety distance, h , beneath the bend to bottom of the furnace. This distance, h , is recommended to be at least $L_e/20$, min. 10 mm, (0.4 in.).

This gives the formula:

$$L_e max. = H \times 0.95 - g \text{ mm for } L_e \geq 200 \text{ mm (7.9 in.)} \tag{...4}$$

$$L_e max. = H - 10 - g \text{ mm (} H - 0.4 - g \text{ in.) for } L_e < 200 \text{ mm (7.9 in.)}$$

Distance between elements

A minimum distance between elements must be applied to prevent the elements from coming in contact with each other due to electromagnetic forces and deformation.

The minimum centre distance, b , between the shanks in two adjacent elements is calculated according to Fig. 48, page 70.

Element data

The element data is calculated as follows:

Power per element, P_e

Total power is divided by the number of elements.

$$P_e = \frac{P}{n} \quad \dots 5$$

Example: $P_e = \frac{250}{18} = 13.89 \text{ kW}$

Surface loading, p

Check with table value for element power and estimate new surface loading.

$$p = \frac{P_e}{P_{e \text{ tab}}} \times p_{\text{tab}}; \quad p_{\text{tab}} \text{ and } P_{e \text{ tab}} \text{ from tables on pages 34 - 48.} \quad \dots 6$$

Example: KANTHAL SUPER 1700 9/18, See table page 36.

$$\begin{array}{ll} L_u = 500 \text{ mm (19.7 in.)} & P_{e \text{ tab}} = 11\,380 \text{ W} \\ L_e = 1120 \text{ mm (44 in.)} & p_{\text{tab}} = 16.6 \text{ W/cm}^2 \text{ (107 W/in.}^2\text{)} \\ a = 60 \text{ mm (2.36 in.)} & \end{array}$$

$$p = \frac{13\,890}{11\,380} \times 16.6 = 20.3 \text{ W/cm}^2$$

$$() \quad p = \frac{13\,890}{11\,380} \times 107 = 131 \text{ W/in.}^2$$

Element temperature, T_e

Estimate element temperature from the temperature - loading diagram in Fig. 27, page 52.

Example: At $p = 20.3 \text{ W/cm}^2 \text{ (131 W/in.}^2\text{)}$ and $T_f = 1150^\circ\text{C} \text{ (2100}^\circ\text{F)}$, $T_e \approx 1520^\circ\text{C} \text{ (2770}^\circ\text{F)}$.

8

Hot resistance, R_t

Calculate total rod length of the heating zone, L_H and of terminals, L_T .

For two-shank elements

$$L_H = \frac{2 L_e + 20 + 0.57a - d}{1000} \text{ m} \quad \dots 7a$$

$$() \quad L_H = 2 L_e + 0.8 + 0.57a - \frac{d}{25.4} \text{ in.} \quad (d \text{ in mm})$$

For multi-shank elements

$$L_H = \frac{2 L_e + 20 + B(S - 2) + (S - 1) (0.57a - d)}{1000} \text{ m} \quad \dots 7b$$

$$() \quad L_H = 2 L_e + 0.8 + B(S - 2) + (S - 1) \left(0.57a - \frac{d}{25.4}\right) \text{ in.} \quad (d \text{ in mm})$$

$$L_T = \frac{2 L_u}{1000} \text{ m} \quad \dots 8$$

$$() \quad L_T = 2 L_u \text{ in.}$$

Calculate resistance in Ω/m for KANTHAL SUPER 1700 and 1800.

See also diagram in Fig. 26, page 63.

Resistance is calculated at actual element temperature, T_e .

$$r_e = \frac{(0.0028 \times T_e - 0.255)}{d^2} \quad \text{for } T_e > 600 \text{ }^\circ\text{C} \quad \dots 9$$

$$r_u = \frac{(0.00196 \times T_f - 0.255)}{D^2} \quad \dots 10$$

Calculate resistance in $\Omega/\text{in.}$ for KANTHAL SUPER 1700 and 1800

$$() \quad r_e = \frac{(0.393 \times T_e - 71) \times 10^{-4}}{d^2} \quad \text{for } T_e > 1000 \text{ }^\circ\text{F} \quad (d \text{ in mm}) \quad \dots 9$$

$$() \quad r_u = \frac{(0.275 \times T_f - 71) \times 10^{-4}}{D^2} \quad (D \text{ in mm}) \quad \dots 10$$

Calculate resistance in Ω/m for KANTHAL SUPER 1900
See also diagram in Fig. 26, page 51.

$$r_e = \frac{(0.00261 \times T_e - 0.255)}{d^2} \quad \text{for } T_e > 900 \text{ }^\circ\text{C} \quad \dots 11$$

$$r_u = \frac{(0.00183 \times T_f - 0.255)}{D^2} \quad \dots 12$$

Calculate resistance in $\Omega/in.$ for KANTHAL SUPER 1900

$$() \quad r_e = \frac{(0.391 \times T_e - 78) \times 10^{-4}}{d^2} \quad \text{for } T_e > 1650 \text{ }^\circ\text{F} \quad (d \text{ in mm}) \quad \dots 11$$

$$() \quad r_u = \frac{(0.274 \times T_f - 78) \times 10^{-4}}{D^2} \quad (D \text{ in mm}) \quad \dots 12$$

Total resistance, R_t is calculated:

$$R_t = (r_e \times L_H) + (r_u \times L_T) \quad \dots 13$$

Example: KANTHAL SUPER 1700 9/18.

$L_u = 500 \text{ mm (19.7 in.)}$ $T_f = 1150 \text{ }^\circ\text{C (2100 }^\circ\text{F)}$
 $L_e = 1120 \text{ mm (44.1 in.)}$ $T_e = 1520 \text{ }^\circ\text{C (2770 }^\circ\text{F)}$
 $a = 60 \text{ (2.36 in.)}$

$$R_t = \frac{0.0028 \times 1520 - 0.255}{9^2} \times \frac{2 \times 1120 + 20 + 0.57 \times 60 - 9}{1000} +$$

$$\frac{0.00196 \times 1150 - 0.255}{18^2} \times \frac{2 \times 500}{1000} = (0.0494 \times 2.285) + (0.0062 \times 1) =$$

$$0.113 + 0.006 = 0.119\Omega$$

$$() \quad R_t = \frac{(0.393 \times 2770 - 71)}{9^2} \times 10^{-4} \times \left(2 \times 44.1 + 0.8 + 0.57 \times 2.36 - \frac{9}{25.4} \right)$$

$$+ \frac{(0.275 \times 2100 - 71)}{18^2} \times 10^{-4} \times 2 \times 19.7 = (0.00126 \times 90) + (0.000156 \times 39.4) =$$

$$0.113 + 0.006 = 0.119\Omega$$

8

Element voltage, U_e

$$U_e = \sqrt{P_e \times R_t} \quad \dots 14$$

Example: $U_e = \sqrt{13\,890 \times 0.119} = 40.65 \text{ V}$

Current, I

$$I = \frac{U_e}{R_t} \quad \dots 15$$

Example: $I = \frac{40.65}{0.119} = 342 \text{ A}$

Element power, P_e

$$P_e = R_t \times I^2 \quad \dots 16$$

Example: $P_e = 0.119 \times 342^2 \approx 13\,900 \text{ W}$

Examples of element calculations

Example 1

Laboratory furnace, T_f max. 1700 °C (3090 °F)

Inside dimensions:

Width	180 mm	7.1 in.	Line voltage	400/230 V
Height	210 mm	8.3 in.	Control	Thyristor, phase-angle fired
Depth	255 mm	10 in.	Elements	KANTHAL SUPER 1800 3/6 or 4/9
Roof insulation, L_1	90 mm	3.5 in.		

The chamber volume is calculated: $V = 1.8 \times 2.1 \times 2.55 \approx 10 \text{ dm}^3$
 $(V = 7.1 \times 8.3 \times 10 \approx 589 \text{ in.}^3 \approx 0.34 \text{ ft}^3)$

Since it is a laboratory furnace the charge is not known.

According to the diagram Fig. 52, page 76 the power needed is 6 kW

Terminal length, L_u **...3**

$$L_{u \text{ min}} = 90 + 50 + 15 = 155 \text{ mm} \quad (3.5 + 2 + 0.6 = 6.1 \text{ in.})$$

Closest standard length 160 mm (6.3 in.) for 3/6 and 4/9 elements.

Heating zone length, L_e

...4

8

$$L_{e \max} = 210 \times 0.95 - 15 = 185 \text{ mm } ((8.3 - 0.6) \times 0.95 = 7.3 \text{ in.})$$

Closest standard length 180 mm (7.1 in.)

Number of elements, n

Check power per element according to tables in pages 39 – 40

For 3/6 element $P_e = 500 \text{ W}$, and 4/9 element $P_e = 649 \text{ W}$ at 12 W/cm^2 (77 W/in.^2)
 $T_f = 1600 \text{ }^\circ\text{C}$ ($2910 \text{ }^\circ\text{F}$) and $T_e = 1700 \text{ }^\circ\text{C}$ ($3090 \text{ }^\circ\text{F}$).

According to the temperature - loading diagram on page 64, 12 W/cm^2 (77 W/in.^2) is within the recommendations also at $T_f = 1700 \text{ }^\circ\text{C}$ ($3090 \text{ }^\circ\text{F}$).

$$\text{Number of 3/6 elements will be } \frac{6\,000}{500} = 12$$

$$\text{Number of 4/9 elements will be } \frac{6\,000}{649} = 9.2, \text{ say } 10 \text{ pcs.}$$

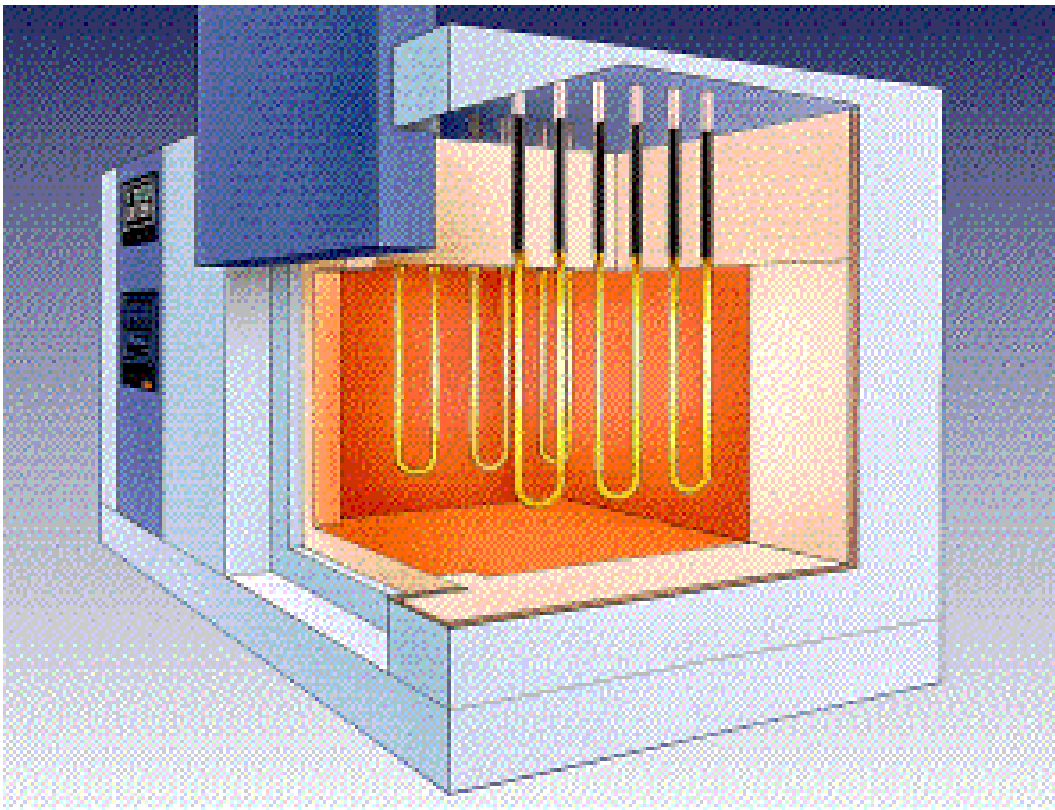

Fig.53 High temperature laboratory furnace.

8

Distance between elements

Wall length is 255 mm.

Using 3/6 elements, the centre distance between elements will be

$$\frac{255}{6} = 42.5 \text{ mm} \quad \left(\frac{10}{6} = 1.7 \text{ in.} \right)$$

Using 4/9 elements, the centre distance between elements will be

$$\frac{255}{5} = 51 \text{ mm} \quad \left(\frac{10}{5} = 2 \text{ in.} \right)$$

According to diagram in Fig. 48, page 83 $b/a = 0.95$ for $L_e = 180 \text{ mm}$ (7.1 in.) at a surface loading of 12 W/cm^2 (77 W/in.^2).

Minimum centre distance between elements when mounted:

a) parallel to the wall;

$$a + b = 25 + 0.95 \times 25 = 49 \text{ mm} \quad (1 + 0.95 \times 1 = 1.95 \text{ in.})$$

and,

b) perpendicular to the wall;

$$b = 0.95 \times 25 = 24 \text{ mm} \quad (0.95 \times 1 = 0.95 \text{ in.})$$

It is preferred that the elements are mounted parallel to the walls therefore ten pcs 4/9 elements are selected.

Power per element, P_e

...5

$$P_e = \frac{6000}{10} = 600 \text{ W}$$

Surface loading, p

...6

Nominal power according to table on page 41 is 649 W at a surface loading of 12 W/cm^2 (77 W/in.^2)

$$p = \frac{600 \times 12}{649} \approx 11.1 \text{ W/cm}^2 \quad (72 \text{ W/in.}^2)$$

According to the loading diagram on page 64 the element temperature will be $\approx 1770 \text{ }^\circ\text{C}$ ($3220 \text{ }^\circ\text{F}$).

Hot Resistance, R_t

...13

$$R_t = \frac{0.0028 \times 1770 - 0.255}{4^2} \times \frac{2 \times 180 + 20 + 0.57 \times 25 - 4}{1000} + \frac{0.00196 \times 1700 - 0.255}{9^2} \times 2 \times \frac{160}{1000} = (0.294 \times 0.39) + (0.0380 \times 0.32) = 0.115 + 0.012 = 0.127 \Omega$$

$$() R_t = \frac{0.393 \times 3220 - 71}{4^2} \times 10^{-4} \times \left(2 \times 7.1 + 0.8 + 0.57 \times 1 - \frac{4}{25.4} \right) + \frac{0.275 \times 3090 - 71}{9^2} \times 10^{-4} \times 2 \times 6.3 = (0.00747 \times 15.4) + (0.0010 \times 12.6) = 0.117 + 0.012 = 0.127 \Omega$$

Element voltage, U_e

...14

$$U_e = \sqrt{600 \times 0.127} = 8.7 V$$

Current, I

...15

$$I = \frac{8.7}{0.127} = 68.5 A$$

Final element data: 10 pcs KANTHAL SUPER 1800 4/9

$L_u = 160$ (6.3 in.)	$P_e = 600$ W	$T_e = 1770$ °C (3220 °F)
$L_e = 180$ (6.3 in.)	$U_e = 8.7$ V	
$a = 25$ (1 in.)	$I = 68.5$ A	
	$R_t = 0.127$ Ω	
	$p = 11.1$ W/cm ² (72 W/in. ²)	

Electrical equipment.

The elements could be connected all in series to a single phase transformer since this is a relatively small furnace.

Secondary voltage of the transformer is $U_e \times n = 8.7 \times 10 = 87 V$.

Since the resistance of cold elements is low the voltage must be controlled in such a way that the maximum continuous element current does not exceed 115 A (see page 79).

The maximum potential power of the furnace during operation is $U_{tot} \times I_{max} = 87 \times 115 = 10\,000 W$ and the power supply should be rated at no less than this.

The supply to which the furnace is being connected consists of two lines of a 400 V, three-phase system.

The maximum primary current will be $VA_{max}/U_{supply} = 10\,000/400 = 25 A$.

For power control, a single phase, phase-angle fired thyristor unit rated at 400 V should be connected to the primary side of the transformer with current limit set to 25 A (R.M.S.) incorporating a soft start (transformer inrush protection).

8 Example 2

Sealed quench furnace with endogas atmosphere, T_f max. 1100 °C (2010 °F).

Inside dimensions:

Width	1300 mm (51 in.)	Roof insulation L_1	280 mm (11 in.)
Height	1300 mm (51 in.)	(including plate).	
Depth	1300 mm (51 in.)	Line voltage	400/230 V
		Control	Thyristor

This is an existing furnace and is presently equipped with twelve pcs 102 mm 4" gas heated radiant tubes with an installed power of 227 000 kcal/h. This is to be rebuilt to electric heating.

Total power, P

...2

$$227\,000 \text{ kcal/h} = 227\,000 \times 1.163 \times 10^{-3} = 264 \text{ kW}$$

The system efficiency of this furnace is estimated to be 40%.

The efficient power is then $264 \times 0.4 = 106 \text{ kW}$

The efficiency of this furnace retrofitted to electric is estimated at 80%

The installed power should be $\frac{106}{0.8} = 132 \text{ kW}$

Number of elements, n

Since there are twelve pieces radiant tubes installed in the furnace, it is suitable to replace them with the same number of KANTHAL SUPER elements.

Terminal Length, L_u

...3

$L_{c \min} = 140 \text{ mm}$ (5.5 in.). See page 90.

$L_{u \min} = 280 + 140 + 30 = 450 \text{ mm}$ (11 + 5.5 + 1.2 in. = 17.7 in.), which is a standard length.

Heating zone length, L_e

...4

$L_{e \max} = 1300 \times 0.95 - 30 \approx 1205 \text{ mm}$ (51 × 0.95 - 1.2 ≈ 47.3 in.).

The closest standard length 1120 mm (44.1 in.).

Power per element, P_e

...5

$$P_e = \frac{132}{12} = 11\,000 \text{ W}$$

For an element KANTHAL SUPER 1700 9/18, $L_u = 450$ (17.7 in.), $L_e = 1120$ (44.1 in.), $a = 60$ (2.36 in.), the nominal power according to table on page 38 is 11 310 W at a surface loading of 16.6 W/cm² (107 W/in.²).

Surface loading in our case will be $p \approx \frac{11\,000}{11\,310} \times 16.6 \approx 16.1 \text{ W/cm}^2$ (104 W/in.²)

According to the loading diagram in Fig. 27, page 52, the $T_e \approx 1435 \text{ °C}$ (2615 °F) at $T_f = 1100 \text{ °C}$ (2010 °F).

Hot Resistance, R_t

...13

8

$$R_t = \frac{0.0028 \times 1435 - 0.255}{9^2} \times \frac{2 \times 1120 + 20 + 0.57 \times 60 - 9}{1000} +$$

$$\frac{0.00196 \times 1100 - 0.255}{18^2} \times 2 \times \frac{450}{1000} = (0.0465 \times 2.285) + (0.0059 \times 0.9) =$$

$$0.106 + 0.005 = 0.111\Omega$$

$$(\text{I}) R_t = \frac{0.393 \times 2615 - 71}{9^2} \times 10^{-4} \times \left(2 \times 44.1 + 0.8 + 0.57 \times 2.36 - \frac{9}{25.4} \right) +$$

$$\frac{0.275 \times 2010 - 71}{18^2} \times 10^{-4} \times 2 \times 17.7 = (0.00118 \times 90) + (0.00015 \times 35.4) =$$

$$0.106 + 0.005 = 0.111\Omega$$

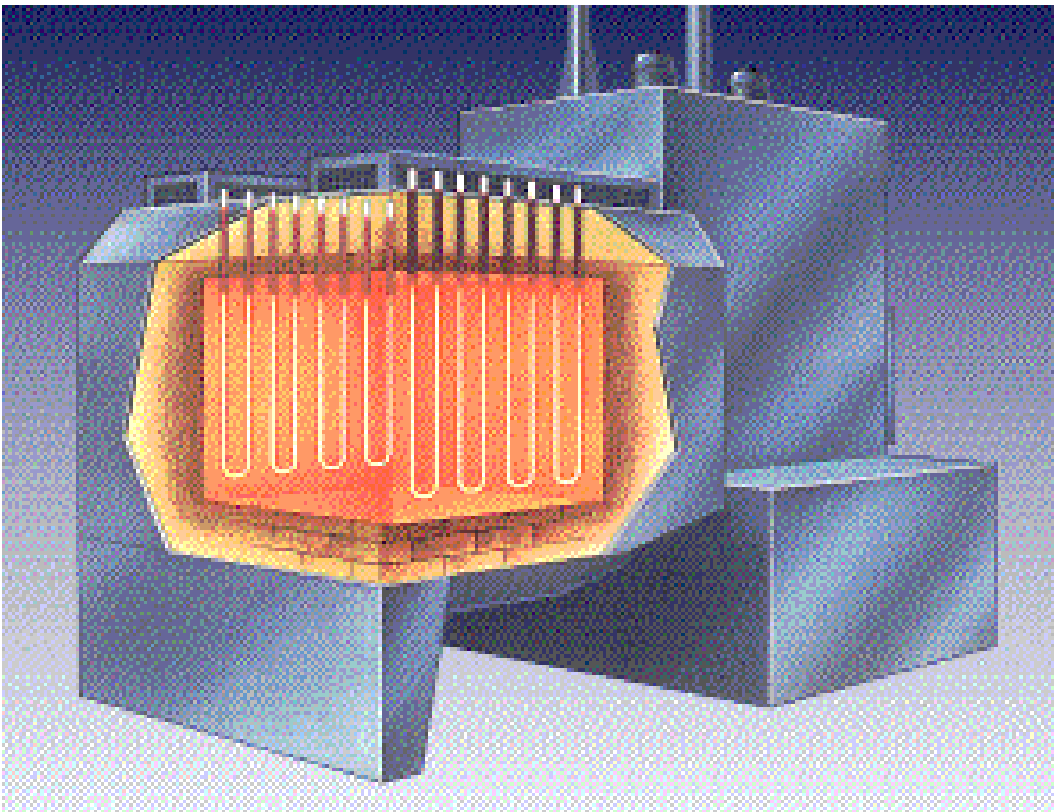

Fig. 54 Sealed quench furnace.

8

Element voltage, U_e **...14**

$$U_e = \sqrt{11\,000 \times 0.111} \text{ V} = 34.9 \text{ V}$$

Current, I **...15**

$$I = \frac{34.9}{0.111} = 315 \text{ A}$$

Final element data: 12 pcs KANTHAL SUPER 1700 9/18

$L_u = 450$ (17.7 in.)	$P_e = 11\,000$ W	$T_e = 1435$ °C (2615 °F)
$L_e = 1120$ (44.1 in.)	$U_e = 34.9$ V	
$a = 60$ (2.36 in.)	$I = 315$ A	
	$R_t = 0.111$ Ω	
	$p = 16.1$ W/cm ² (104 W/in. ²)	

Electrical equipment.

It is advised that the elements are delta connected to a three-phase transformer as shown in Fig. 59 c, page 110 (thyristor control), or Fig. 60 b, page 99 (on/off control).

Secondary voltage of the transformer is $U_e \times n = 34.9 \times 4 \approx 140$ V.

Maximum element current for 9/18 elements is 365 A (see page 67).

The maximum potential power of the furnace during operation is

$$\frac{U_{tot} \times I_{max} \times 3}{1000} = \frac{140 \times 365 \times 3}{1000} \approx 153 \text{ kW}$$

The power supply should be rated at no less than 153 kVA.

At supply voltage of 400 V the maximum line current is

$$\frac{P_{tot}}{U_{supply} \times \sqrt{3}} = \frac{153\,000}{400 \times \sqrt{3}} \approx 221 \text{ A}$$

In this case thyristor control is selected. The nearest standard size of three-phase thyristor is 250 A 440 V.

Example 3

Rotary hearth furnace, T_f max. 1300 °C (2370 °F), nitrogen atmosphere.

Inside dimensions:

Diameter, outer wall	4700 mm (185 in.)	Width of door opening	1800 mm (71 in.)
Diameter, inner wall	1650 mm (65 in.)	Line voltage	400/230 V
Height	1525 mm (60 in.)	Control	Thyristor
Roof insulation L_i	300 mm (12 in.)	Weight of steel billets	1500 kg/hour

The heating capacity for iron at 1300 °C (2370 °F) is 0.245 kWh/kg according to Appendix 2, Fig. 75 on page 135.

The power needed according to the actual charge is determined as follows:

$$P_c = 0.245 \times 1500 = 368 \text{ kW} \quad \dots 1$$

Total power, P ...2

$$P = \frac{P_c}{\eta} \quad \eta = 0.6 \text{ (see page 88)} \quad P = \frac{368}{0.6} = 613 \text{ kW}$$

The elements should be installed vertically along both outer and inner walls.

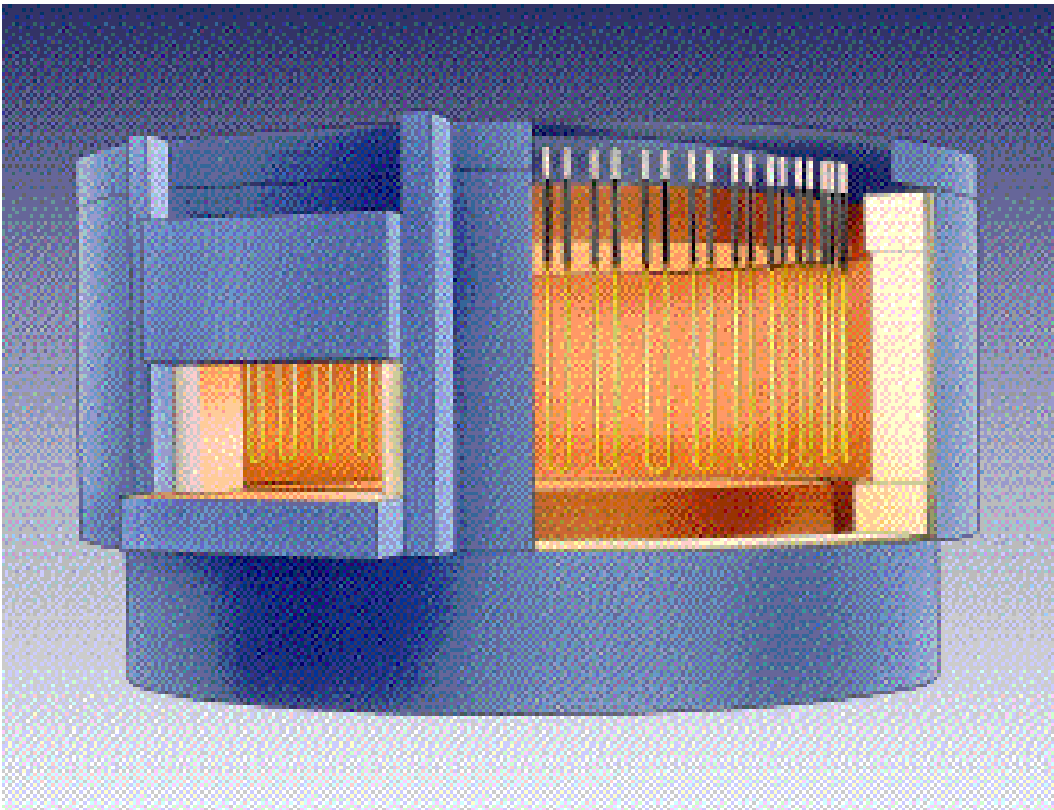

Fig. 55 Rotary hearth furnace.

8 Heated area is calculated: $A = (\pi \times 4.7 - 1.8) + \pi \times 1.65) \times 1.525 = 27.7 \text{ m}^2$

$$() A = (\pi \times 185 - 71) + \pi \times 65) \times \frac{60}{144} = 298 \text{ ft}^2$$

Wall loading is calculated: $\frac{P}{A} = \frac{613}{27.7} = 22.1 \text{ kW/m}^2$ $\left(\frac{613}{298} = 2.1 \text{ kW/ft}^2 \right)$

According to diagrams in Fig. 29, page 54, KANTHAL SUPER 9/18 elements installed parallel to the wall are preferred.

Terminal length, L_u

...3

$L_{c \min} = 125 \text{ mm}$ (5.5 in.). See page 77.

$$L_{u \min} = 300 + 125 + 30 = 455 \text{ mm}$$
 (12 + 5 + 1.2 = 18.2 in.)

Closest standard length 500 mm (19.7 in.)

Heating zone length, L_e

...4

$$L_{e \max} = 1525 \times 0.95 - 30 \approx 1420 \text{ mm}$$
 (60 × 0.95 - 1.2 ≈ 55.8 in.)

The maximum standard L_e in table on page 38 is 1400 mm

$L_e = 1400 \text{ mm}$ (55 in.) is O.K. for $T_e \max.$ 1600 °C (2910 °F). See Fig. 12, page 21.

An element temperature above 1500 °C (2730 °F) is preferred in nitrogen atmosphere (see page 13).

Element data for KANTHAL SUPER 1700 9/18. See page 36.

$L_u = 500$ (19.7 in.)	$P_e = 14\,010 \text{ W}$	$T_e = 1550 \text{ °C}$ (2820 °F)
$L_e = 1400$ (44.1 in.)	$U_e = 45.9 \text{ V}$	
$a = 60$ (2.36 in.)	$I = 305 \text{ A}$	
	$R_t = 0,151 \text{ } \Omega$	
	$p = 16.6 \text{ W/cm}^2$ (107 W/in. ²)	

Number of Elements

$$n = \frac{613}{14.01} = 44, \text{ say } 45 \text{ to achieve a symmetrical three phase load.}$$

8

Electrical equipment.

The power can be divided into three star connected regulation groups, which are connected directly to supply voltage. See Fig. 59 a page 96.

Five elements are connected in series to 230 V. This gives $230/5 = 46$ V per element which is close to the table value 45.9 V.

Maximum element current for 9/18 elements is 365 A (see page 67).

The maximum potential power of the furnace during operation is

$$\frac{U_{tot} \times I_{max} \times 9}{1000} = \frac{230 \times 365 \times 9}{1000} \approx 755 \text{ kW.}$$

The power supply should be rated at no less than 755 kVA.

The nearest standard size of three phase thyristor is 400 A 440 V.

An alternative is the three-phase open delta connection. See Fig. 59 b page 96.

Eight elements are connected in series to 400 V. This gives $400/8 = 50$ V per element.

The total number of elements will be 48 pcs instead of 45.

The maximum potential power of furnace during operation is now

$$\frac{400 \times 365 \times 6}{1000} = 876 \text{ kW.}$$

The power supply should be rated at no less than 876 kVA.

The nearest standard size of three-phase thyristor is 400 A 440 V.

Example 4

Melting furnace for lead crystal glass, semi-closed pot.

Furnace temperature max. 1450 °C (2640 °F). Melting capacity 600 kg.

Melting is performed during approximately 8 of every 24 hours.

The energy consumption during the melting period at 1450 °C (2640 °F) is estimated to be about four times higher than when working at 1150 °C (2100 °F).

The lining consists of a combination of brick and ceramic fibre.

Inside dimensions:

Diameter wall	1600 mm (63 in.)	Line voltage	400/230 V
Height	1050 mm (41.3 in.)	Control	Thyristor
Roof insulation L _i	400 mm (15.7 in.)		

In this kind of furnace a normal power consumption for melting is 3 kWh/kg produced glass over a 24 hour cycle.

Using this value the total energy, *E*, consumption during 24 hours can be calculated:

$$E = 600 \times 3 = 1800 \text{ kWh} \quad \begin{array}{l} 8 \text{ h melting needs full power.} \\ 16 \text{ h when working needs 25 \% of full power} \end{array}$$

Then the necessary power input can be calculated:

$$E = 8 \text{ h} \times P + (16 \text{ h} \times 0.25P) \quad P = \frac{1800}{(8 \times 1) + (16 \times 0.25)} = 150 \text{ kW}$$

8

Terminal length, L_u

...3

For 9/18 elements with air cooled holders:

$$L_{c \min} = 140 \text{ mm (5.5 in.)}. \text{ See page 77.}$$

$$L_{u \min} = 400 + 140 + 30 = 570 \text{ mm (16.7 + 5.5 + 1.2 = 23.4 in.)}$$

Closest standard length 630 mm (24.8 in.)

Heating zone length, L_e

...4

$$L_{e \max} = 1050 \times 0.95 - 30 \approx 968 \text{ mm (41.3} \times 0.95 - 1.2 \approx 38 \text{ in.)}$$

Closest standard length 900 mm (35.4 in.)

Number of elements, n

According to table page 36, $P_{e \text{ tab}} = 9490 \text{ W}$.

$$n = \frac{150}{9.49} \approx 15.8 \text{ pcs, say 18 to achieve a symmetrical three-phase load.}$$

Power per element, P_e

...5

$$P_e = \frac{150}{18} = 8333 \text{ W}$$

Surface loading, p

...6

Check with table value and estimate surface loading.

$$p = \frac{8333}{9490} \times 16.6 = 14.6 \text{ W/cm}^2 \quad () \quad p = \frac{9333}{9490} \times 107 = 94 \text{ W/in.}^2$$

Centre distance between the elements.

The elements are calculated to be installed at a diameter of 1400 mm (55.1 in.)

100 mm (4 in.) from the wall.

The circumferential length of the circle is $\pi \times 1400 \approx 4400 \text{ mm} (\pi \times 55.1 \approx 173 \text{ in.})$

The door opening is $\approx 1000 \text{ mm (39.4 in.)}$, where no elements can be placed.

The elements are then installed over a length of $4400 - 1000 \approx 3400 \text{ mm}$

$(173 - 39.4 \approx 134 \text{ in.})$ Calculate the centre distance between the elements:

$$\frac{3400}{18} \approx 189 \text{ mm} \quad () \quad \frac{134}{18} \approx 7.4 \text{ in.}$$

According to diagram Fig. 48, page 70, $b/a \approx 1.75$ for $L_e = 900 \text{ mm}$ at surface loading 14.6 W/cm^2 (94 W/in.^2).

Minimum centre distance between elements when installed parallel to the wall:

$$a + b = 1.75 \times 60 + 60 = 165 \text{ mm (1.75} \times 2.36 + 2.36 = 6.5 \text{ in.)}$$

When installed perpendicular to the wall:

$$b = 1.75 \times 60 = 105 \text{ mm (1.75} \times 2.36 = 4.1 \text{ in.)}$$

The elements can either be mounted perpendicular or parallel to the wall.

Element temperature, T_e

Estimate element temperature from the temperature - loading diagram Fig. 27, page 52. At $p = 14.6 \text{ W/cm}^2$ (94 W/in.^2) and $T_f = 1450 \text{ }^\circ\text{C}$ ($2640 \text{ }^\circ\text{F}$), $T_e \approx 1620 \text{ }^\circ\text{C}$ ($2950 \text{ }^\circ\text{F}$)

Hot Resistance, R_t

...13

$$R_t = \frac{0.0028 \times 1620 - 0.255}{9^2} \times \frac{2 \times 900 + 20 + 0.57 \times 60 - 9}{1000} +$$

$$\frac{0.00196 \times 1450 - 0.255}{18^2} \times 2 \times \frac{630}{1000} = (0.0529 \times 1.845) + (0.0080 \times 1.26) =$$

$$0.0975 + 0.01 = 0.108 \Omega$$

$$(\text{I}) R_t = \frac{0.393 \times 2950 - 71}{9^2} \times 10^{-4} \times \left(2 \times 35.4 + 0.8 + 0.57 \times 2.36 - \frac{9}{25.4} \right) +$$

$$\frac{0.275 \times 2640 - 71}{18^2} \times 10^{-4} \times 2 \times 24.8 = (0.00134 \times 72.6) + (0.00020 \times 49.6) =$$

$$0.0975 + 0.01 = 0.108 \Omega$$

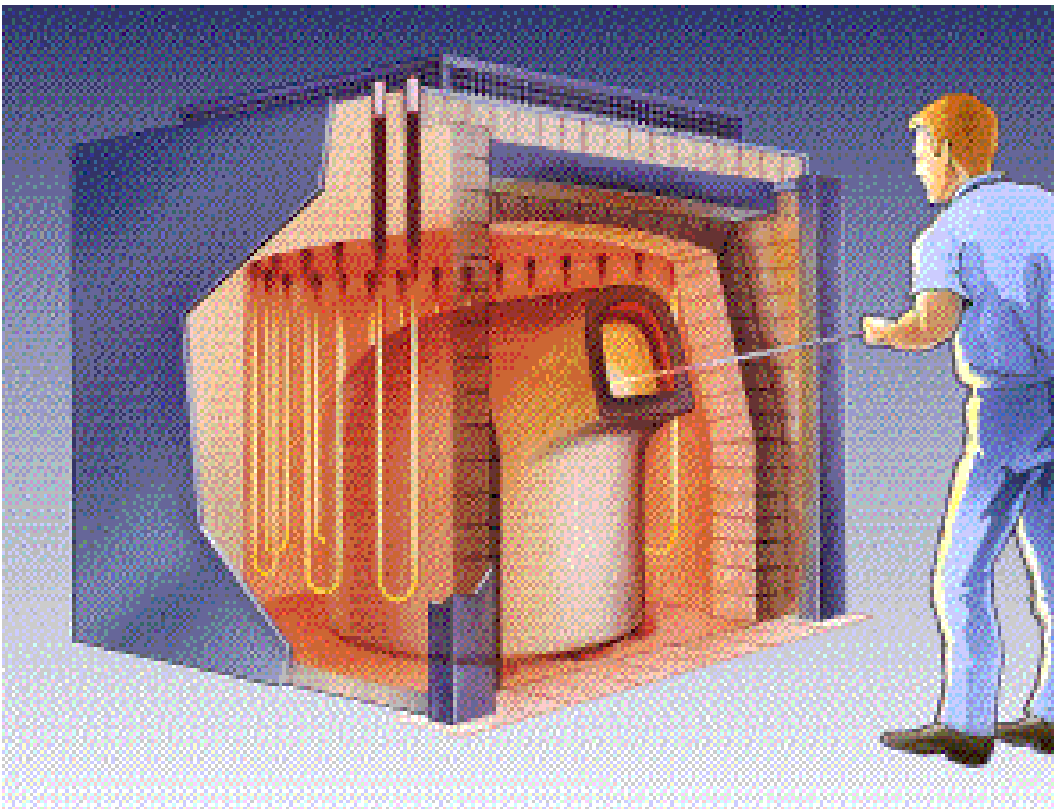

Fig. 56 Pot melting furnace.

8

Element voltage, U_e

...14

$$U_e = \sqrt{8333 \times 0.108} = 30 \text{ V}$$

Current, I

...15

$$I = \frac{30}{0.108} = 278 \text{ A}$$

Final element data: 18 pcs KANTHAL SUPER 1700 9/18

$L_u = 630$ (24.8 in.)	$P_e = 8333 \text{ W}$	$T_e = 1620 \text{ }^\circ\text{C}$ (2950 $^\circ\text{F}$)
$L_e = 900$ (35.4 in.)	$U_e = 30 \text{ V}$	
$a = 60$ (2.36 in.)	$I = 278 \text{ A}$	
	$R_t = 0.108 \text{ } \Omega$	
	$p = 14.6 \text{ W/cm}^2$ (94 W/in.^2)	

Electrical equipment.

It is advised that the elements are delta connected to a three-phase transformer as shown in Fig. 59 c, page 97.

Secondary voltage of the transformer is $U_e \times n = 30 \times 6 = 180 \text{ V}$.

Maximum element current for 9/18 elements is 365 A (see page 79).

The maximum potential power of the furnace during operation is:

$$\frac{U_{tot} \times I_{max} \times 3}{1000} = \frac{180 \times 365 \times 3}{1000} \approx 197 \text{ kW}$$

The power supply should be rated at no less than 197 kVA.

At supply voltage of 400 V the maximum line current is

$$\frac{P_{tot}}{U_{supply} \times \sqrt{3}} = \frac{197\,000}{400 \times \sqrt{3}} \approx 284 \text{ A}$$

The nearest standard size of three-phase thyristor is 300 A 440 V.

Control, power supply and wiring

Material Characteristics

Kanthal Super has two basic material properties that call for special attention when designing the control system.

1. The resistivity increases steeply with temperature (see resistivity curve in Fig. 26, page 51). The resistance of an element at 20 °C is about 11 times lower than the resistance of the same element at 1500 °C (2730 °F). Hence, if full voltage is applied when starting, a peak current of 11 times the nominal current will flow through the element. This would cause fuse blowing or thyristor failure.

2. The material is brittle at low temperature which means that excessive amperage may cause electromagnetic forces large enough to fracture the element.

Control in general

The low cold resistivity of KANTHAL SUPER implies that full operational voltage cannot be applied to a cold furnace.

In the past, only tapped transformers were available, allowing a reduced voltage to be applied when the furnace was cold, and then the voltage was gradually increased as the elements heated up, thus maintaining currents within manageable levels.

With the advent of modern thyristor (SCR) power control units and the various feedback control features available today, we now have a reasonably economical and reliable means of limiting the start-up currents and taking full advantage of KANTHAL SUPER's rapid heat-up capability.

Today furnaces equipped with KANTHAL SUPER elements are controlled in the following ways:

Thyristor control

1. Phase-angle fired thyristors with or without a transformer
2. Burst fired thyristors with phase-angle start with or without a transformer

On/off control

3. Tapped transformer
4. Contactor switch, changing the element connection

9

Thyristor Control

Phase-Angle Firing

In phase-angle firing the power is controlled by allowing the thyristors to conduct for a part of the AC cycle only (see Fig. 57 a). The thyristor should have a current ramp turn on function and a RMS (Root Mean Square) current limit facility. It should be noted that this is not the same as the ramp function of the temperature controller.

The thyristor starts to conduct with a small conduction angle and then it increases towards maximum conduction during a number of periods. The more power needed, the larger part of the sinusoid is allowed to pass through the thyristors. If maximum permitted current is attained before full wave, the current limit facility does not permit further increase of the conduction angle.

It is essential that the current is both measured and limited in the RMS method. The reason for this is that in phase-angle firing, one is working with distorted current wave forms, and then the RMS method of current measuring is the only way to obtain a correct and meaningful value.

The ramp turn on function is required for the thyristor to work properly and gives the current limit function time to work.

The main disadvantage of phase-angle firing is that it generates radio frequency interference that may cause malfunction in sensitive electrical equipment.

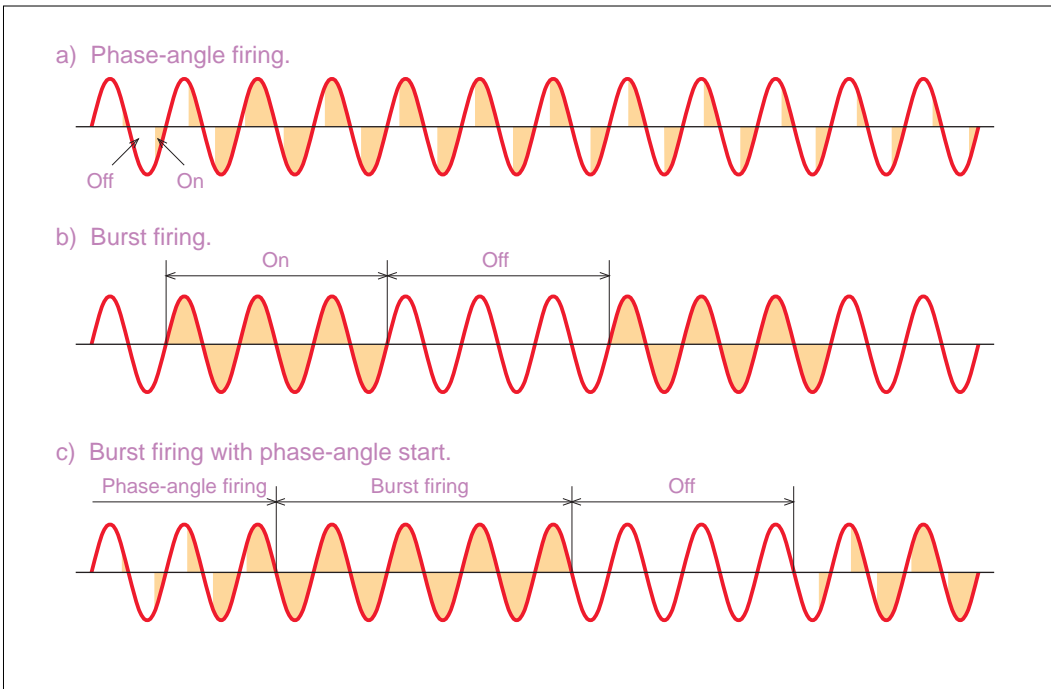

Fig. 57 Thyristor firing modes.

Burst Firing with Phase-Angle start

In burst firing the power is controlled by allowing the thyristors to be conductive for one or more complete cycles and then non-conductive for one or more cycles. The higher the power needed, the more conductive cycles and the fewer non-conductive there are (see Fig. 57 b).

A burst fired thyristor switches on and off when the instantaneous current is zero and therefore creates less transients than non-synchronised equipment.

A usual method of dealing with the disadvantages of phase-angle firing and burst firing is to use a combination of them (see Fig. 57c). Phase-angle firing is used during the heating up of the furnace so that the current can be sufficiently limited without using a step-down transformer with different voltage taps. When the furnace reaches a preset temperature below furnace temperature, at least at 600 - 800 °C (1110 - 1470 °F), an automatic switch is turned to burst firing mode. In this way negligible radio frequency interference is created once the furnace is hot.

Figs. 58 and 59 on pages 96 - 97 show applications with thyristor control.

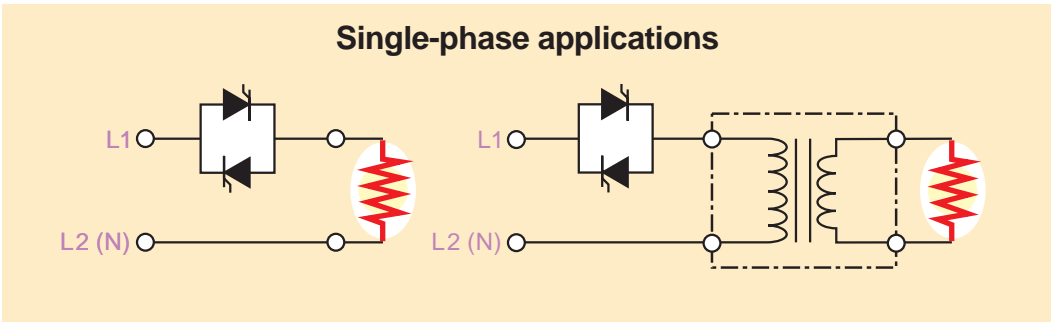

Fig. 58 Applications with thyristor (SCR) control.

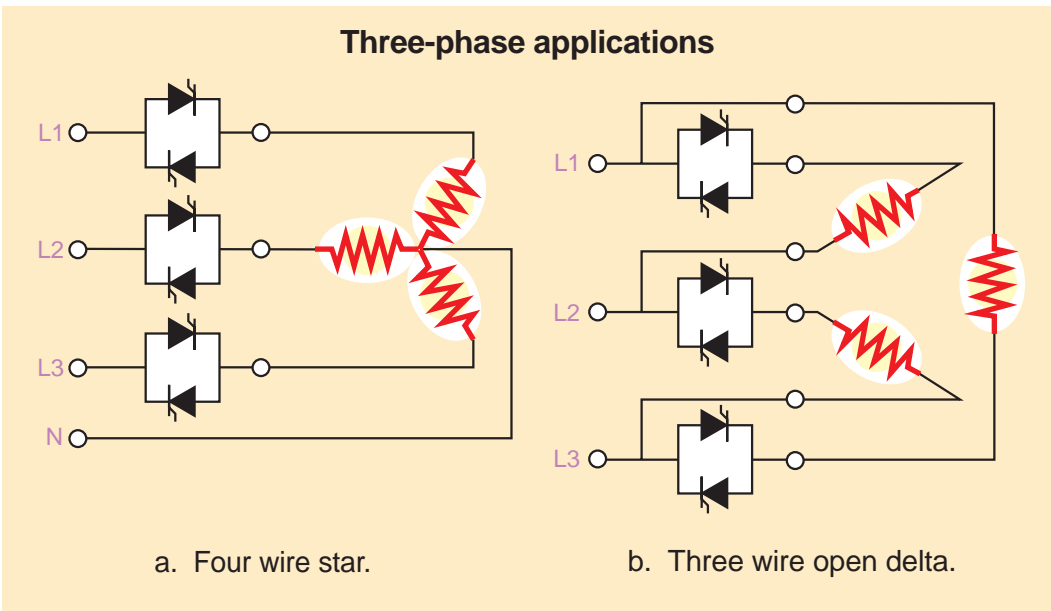
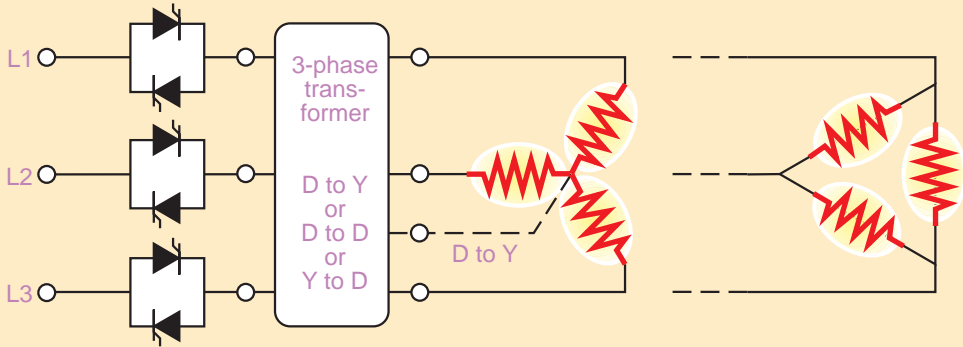

Fig. 59 Applications with thyristor (SCR) control.

9

Three-phase applications



c. Transformer and star or delta load.

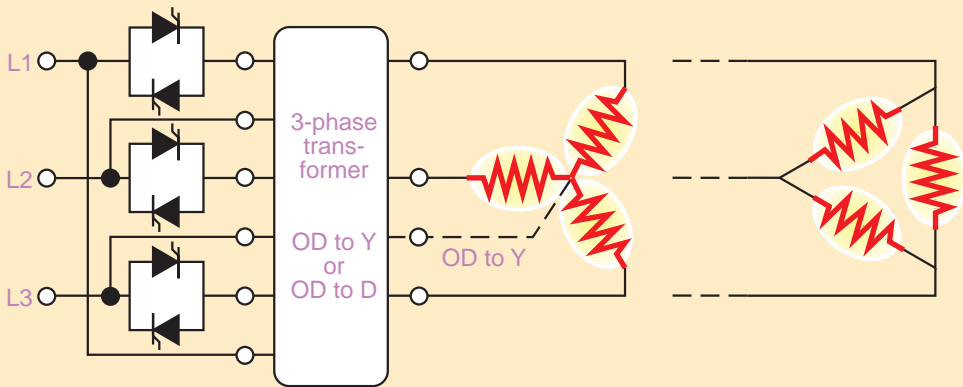

d. Six wire open delta with transformer and star or delta load.

Fig. 59 Applications with thyristor (SCR) control.

On/off Control

Tapped transformer

Controlling a furnace with KANTHAL SUPER elements by a contactor regulated on/off system and a tapped transformer has some disadvantages compared to thyristor control. The main disadvantages are longer on/off periods, which results in less accuracy in temperature control and non-synchronised switching, which means that it creates more transients. There is also mechanical wear on the contactor.

Transformers for stepless voltage regulation are sometimes used to provide accurate control of the energy input in line with the actual requirement.

Fig. 60 on page 98 shows applications with on/off control and tapped transformer.

Single-phase application

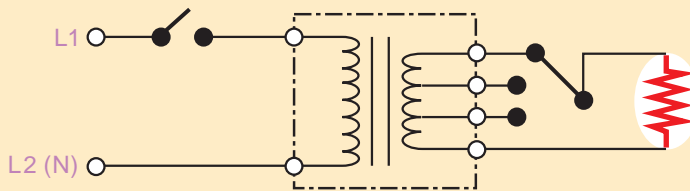

a. Transformer.

Three-phase applications

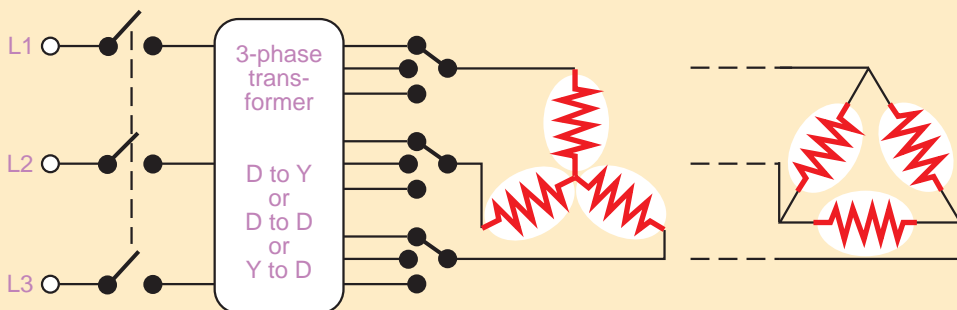

b. Transformer and star or delta load.

Fig. 60 Applications with on/off control.

Contactor switch, changing the element connection

Fig. 61 on page 99 shows a wiring diagram with the elements star-connected to line voltage. By series-connecting all elements between one phase and neutral, the starting voltage is reduced to 33% of full operating voltage. The intermediate step is to connect the elements in series between two phases, which corresponds to 58% of operating voltage. Finally, the elements are switched to star connection.

Fig. 62 on page 100 shows a wiring diagram with the elements delta-connected to line voltage. By series-connecting all elements between two phases, the starting voltage is reduced to 33% of full operating voltage. The intermediate step is to connect the elements in star, which corresponds to 58% of operating voltage. Finally, the elements are switched to delta connection.

At start-up, all elements can also be series-connected between one phase and neutral and the starting voltage is reduced to 19% of full operating voltage.

9

Step 1

All elements series connected between phase and neutral

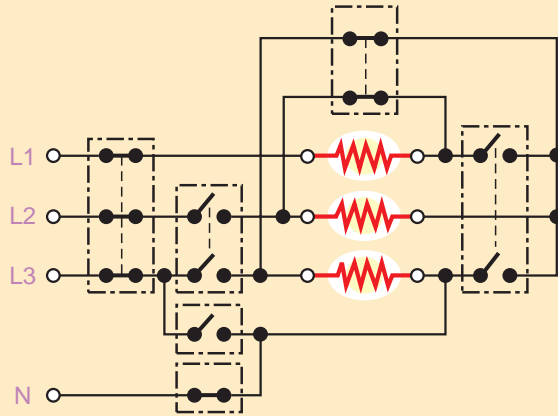

Step 2

All elements series connected to line voltage

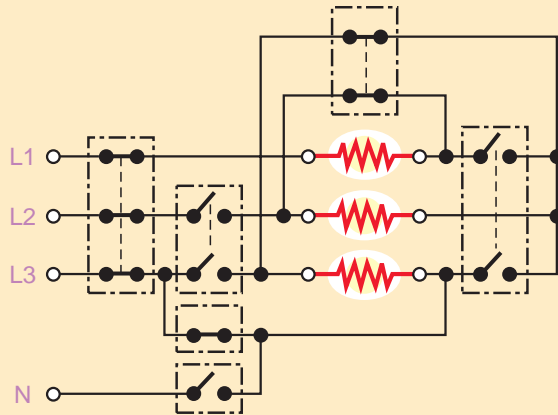

Step 3

Elements star-connected

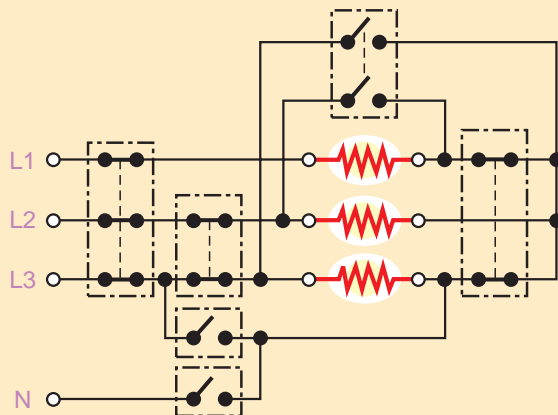
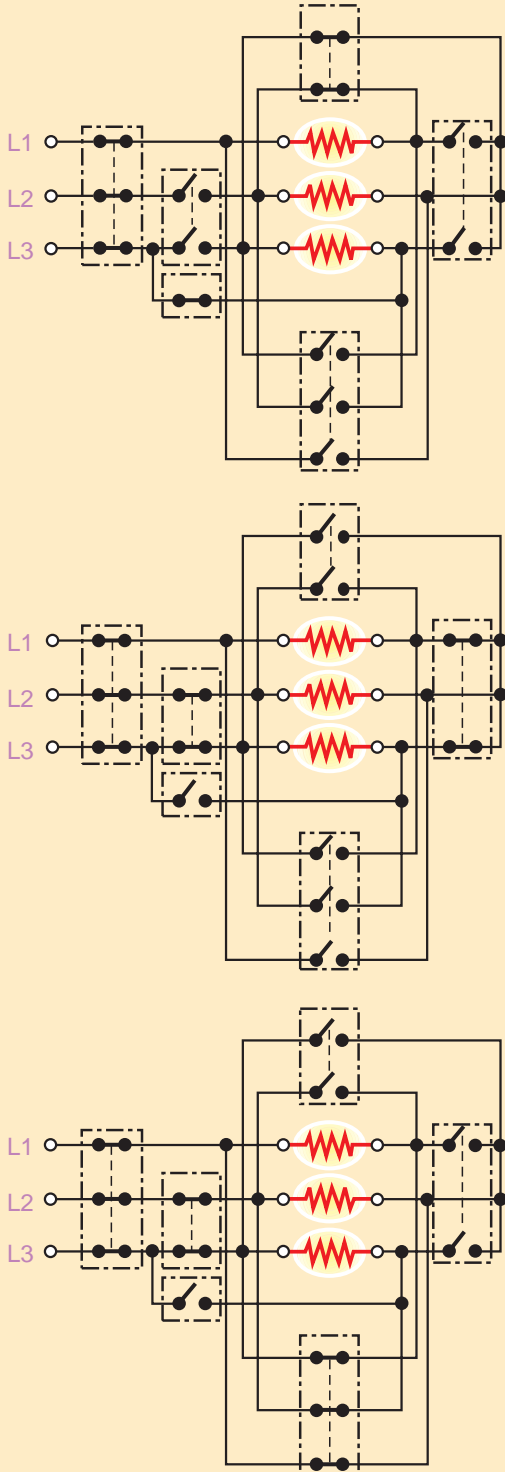

Fig. 61 Wiring diagram for KANTHAL SUPER elements directly star-connected to line voltage.



Step 1

All elements series connected to line voltage

Step 2

Elements star-connected

Step 3

Elements delta-connected

Fig. 62 Wiring diagram for KANTHAL SUPER elements directly delta-connected to line voltage.

Scott-connected transformers

When the number of elements is such that a symmetrical three-phase load on the secondary side of the transformer is not possible e.g. 4, 8, 10, 14 etc. and yet prefer a symmetrical three-phase load on the primary side a scott-connected transformer should be used.

When the load is equal on the two secondary windings, the primary side will be symmetrically loaded. The two secondary phases are electrically displaced by 90° .

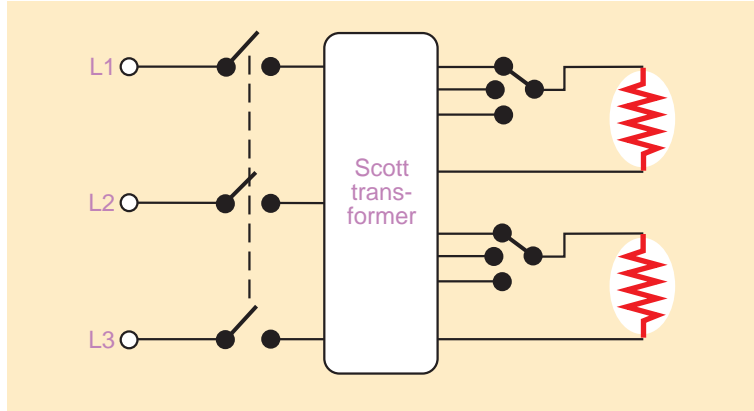

Fig. 63 Application with on/off control and tapped transformer.

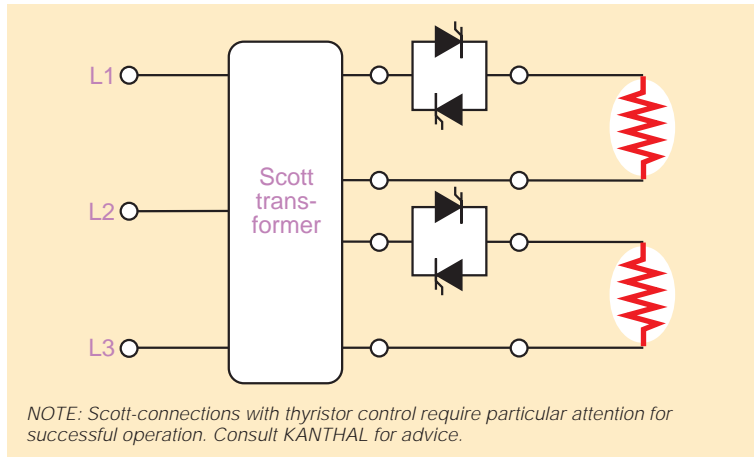

Fig. 64 Application with thyristor control.

Calculation of transformers

Thyristor control

When a transformer is used in combination with thyristor control, it must be designed for working with thyristors. The main difference is that larger iron cores are needed than when using on-off control. The reason for this is to obtain a lower magnetic flux density through the core.

Typical values of flux density are for:

- On/Off controlled transformers: 1.6 T (Tesla)
- Transformer with phase-angle fired thyristors: < 1.4 T

Transformers for on/off control can be used for phase-angle firing to 80 % of their power rating.

The rating of the transformer for thyristor control is calculated in the following way:

- 1.The furnace power needed is determined.
- 2.The size of thyristor is decided.
- 3.The size of transformer is based on the maximum power that the thyristor needs to control. Generally the transformer is rated 10 -20 % higher than the furnace power.

On/off control

When a transformer is used in combination with on/off control, it must be designed for the maximum continuous loading.

Generally it is accurate enough to calculate the power at full operating element voltage and the maximum current permitted for the actual element dimension. Maximum continuous element current for different element dimensions is:

Element size:	3/6	4/9	6/12	9/18	12/24
Current (A)	75	115	200	365	560

When heating a furnace from room temperature the starting voltage is normally 1/3 or 1/4 of operating voltage to avoid overloading of the electrical equipment. Transformers provided with steps for 1/3, 2/3, or 1/4, 1/2, 3/4, and full operating voltage are utilized.

Wiring to counteract electromagnetic forces

Current passing through two parallel conductors produces an electromagnetic force between them. If the current flows in the same direction in the two conductors, there is an attracting force and if it flows in the opposite direction there is a repelling force.

Hence, in a 2-shank KANTHAL SUPER element, a repelling force is set up between the two shanks, which leads to an increase in the distance, α , between the shanks of the heating zone.

The result of the repelling force and gravitation on the heating zone of a vertically mounted KANTHAL SUPER element means that a state of equilibrium tends to be reached.

The degree of deformation depends on the amperage I, the length of the heating zone L_e , and the distance between the shanks α .

The diagram in Fig. 49, page 84 shows how to calculate the distances necessary to counteract the effect of electromagnetic force on KANTHAL SUPER elements.

9

The effect of the repelling force is reduced if the distance between the shanks is increased. It has been found from practical experience that to avoid excessive deformation, the minimum value of, a , should not be below the following:

Element size	Minimum a	Normal a
12/24	50 mm (2 in.)	80 mm (3,1 in.)
9/18	40 mm (1.5 in.)	60 mm (2,4 in.)
6/12	25 mm (1 in.)	50 mm (2 in.)
4/9	20 mm (0.8 in.)	25 mm (1 in.)
3/6	20 mm (0.8 in.)	25 mm (1 in.)

If two or more elements are installed together, it is important that they are connected in such a way that the current flows in the opposite direction in two adjacent shanks that are placed close together. Theoretically, if all the repelling effects are of the same magnitude, they balance each other and do not increase the distance between the element shanks. Normally, the distance between adjacent elements is greater than, a , and consequently the repelling effect between the two shanks of an element will dominate. The result is an increase in, a .

In the case of element groups connected to a three-phase supply, the connecting points should be combined in such a way that the currents in the adjacent shanks of two KANTHAL SUPER elements have a phase displacement of 120° . Regardless of the phase displacement, it is always a repelling force which occurs between the two shanks of a KANTHAL SUPER element, and which varies between zero and maximum. See Fig. 65.

In Fig. 66 "Correct" page 117, the electromagnetic force between shank "B" (through which a current " I_1 " flows) and shank "C" (through which a current " I_2 " flows) produces a repelling effect due to the angular displacement between the two phases to which the elements are connected.

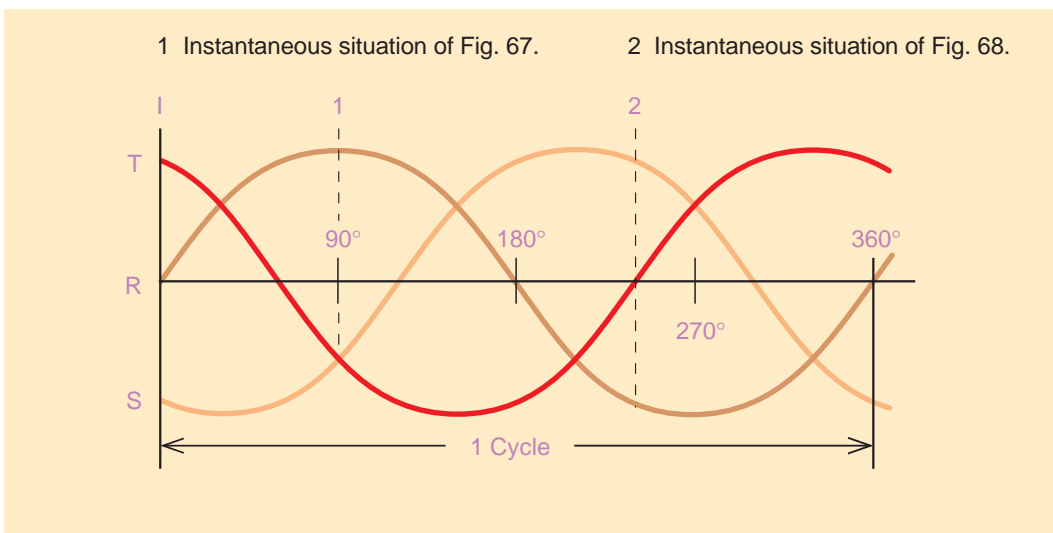

Fig. 65 Sine curve variations in a three-phase system.

Correct

Incorrect

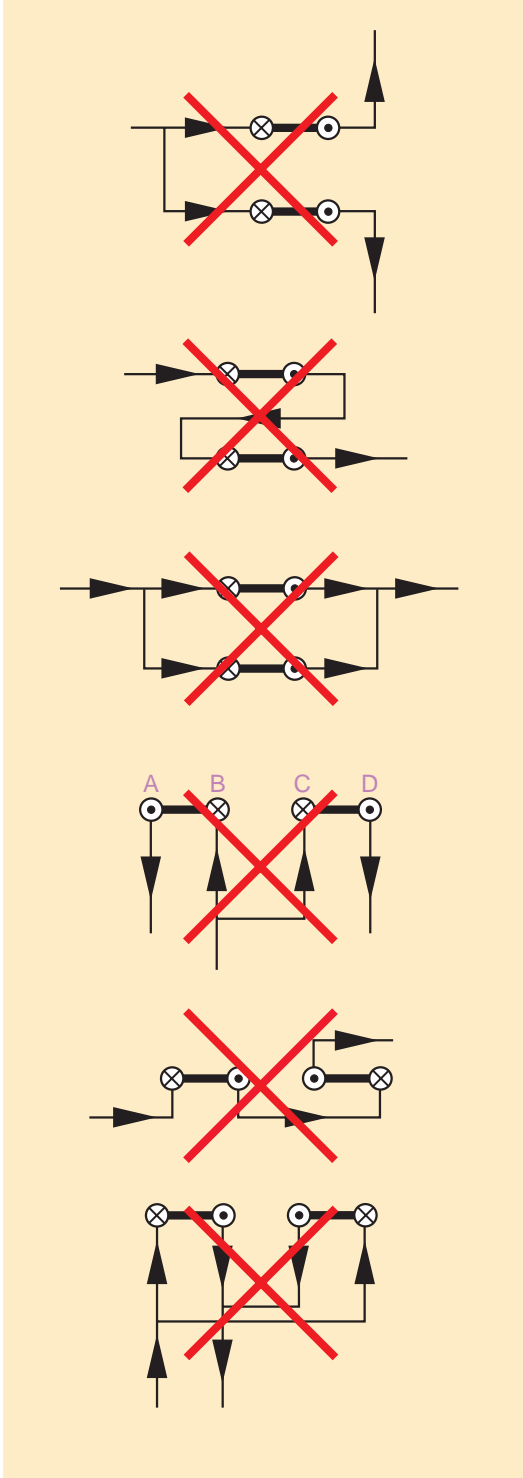
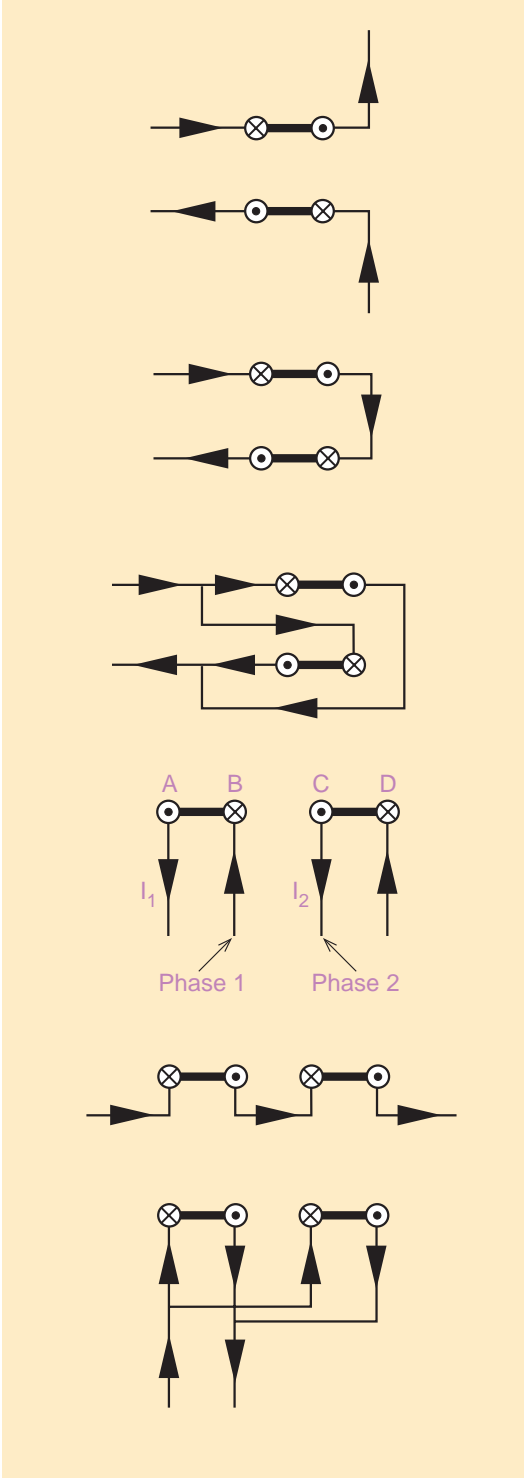
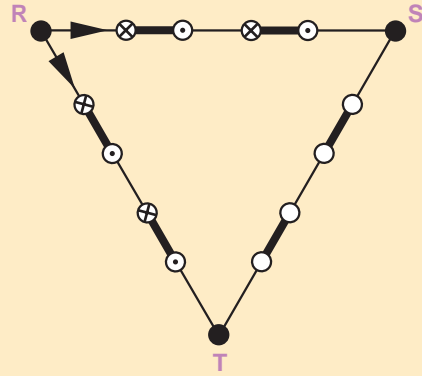
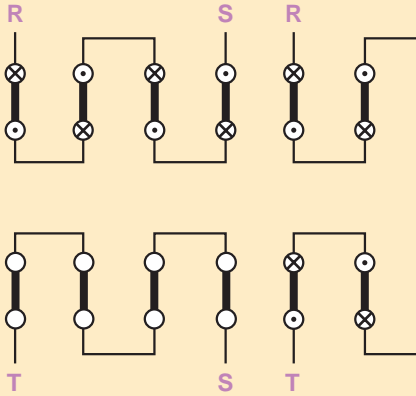

Fig. 66 Examples of correct and incorrect connections.

9



Consider that the current enters in R and flows to S and T.
 Momentarily no current is passing through the leg ST. See Fig. 65 page 116.
 Then the same procedure starting from S and then T is followed.

Fig. 67 Delta-connected arrangement.

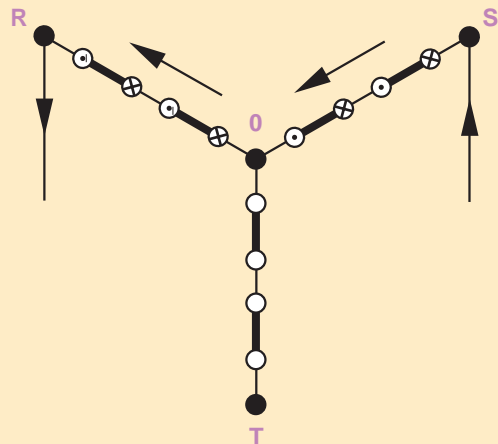
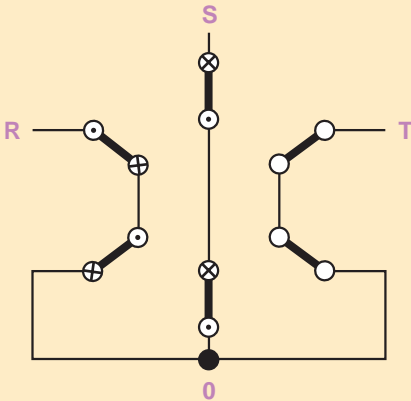

Consider that the current enters in S and flows through O to R. See Fig. 65, page 116.
 Then the same procedure starting from T and then R is followed.

Fig. 68 Star-connected arrangement.

In three-phase systems the connecting points should be combined in such a way that the currents in the adjacent shanks of two KANTHAL SUPER elements have a phase displacement of 120° . Any other connection should be avoided, since the magnetic force will then have a predominantly attracting effect. This intensifies the effect of the repelling forces acting on the two elements, which can lead to severe deformation.

In order to facilitate the correct connection of KANTHAL SUPER elements to a three-phase supply, bearing in mind that the phases are 120° apart, the current flow directions should be regarded as in Fig. 67 and 68, page 105 as follows:

1. The current in two phases flow in opposite directions

During part of the cycle the currents will flow in the same direction. The maximum attracting effect is obtained when the currents have half the value of the momentary maximum current. The average action, however, is repelling.

2. Two currents from the neutral point flow in opposite directions

The same as under 1. above.

3. Two currents which come from a common phase connecting point flow in the same direction

Remember that two currents from a common phase connection always flow in the same direction. Adjacent elements must never be connected in parallel to the same phase.

Fig. 69 Multi purpose controlled atmosphere kiln.

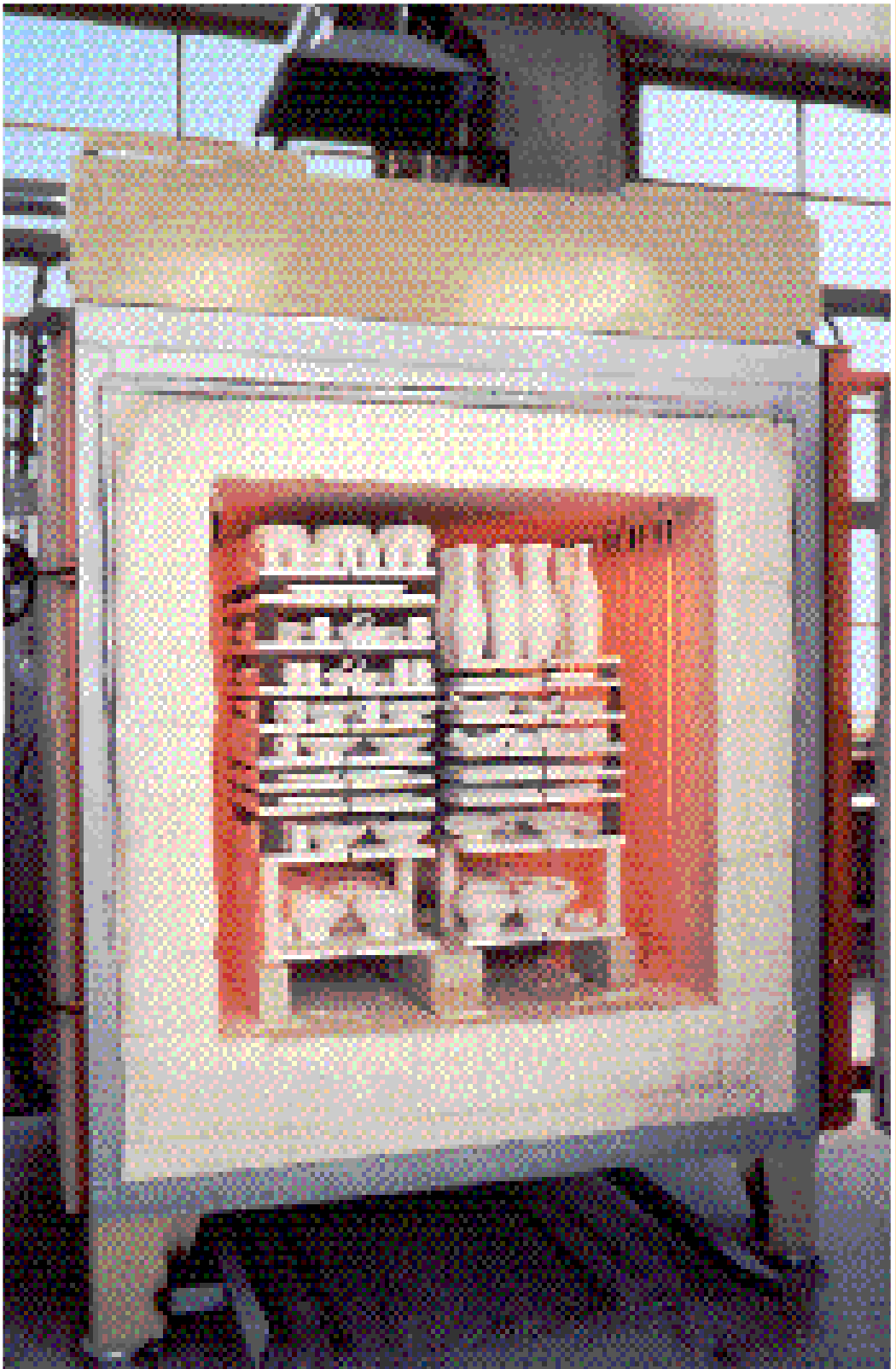

Furnace operation

Initial start-up procedure recommendations

- Review the installation instructions of the furnace to verify that it is in operating condition.
- Become familiar with the various adjustments on the controller or programmer before operating the furnace for the first time.
- Do not leave the furnace unattended during the initial break-in period.
- Check the current limit of the power controller. Generally the current limit is preadjusted before shipping.
- Note that fibrous insulation is fragile and that the KANTHAL SUPER heating elements are also subject to breakage if handled improperly. Take special care with all furnace components at all times.

Starting up a newly-built furnace

When starting up a furnace for the first time or after it has been relined, it is necessary to dry it out so that the lining is not damaged. This is especially important when the furnace is brick lined. As far as the KANTHAL SUPER elements are concerned, the quicker the furnace can be brought up to full operating temperature, the better. The elements may also be attacked by gases and dust given off from the lining during the first firing of a furnace. It is therefore very important to ventilate the furnace thoroughly during the drying-out process.

We recommend the following procedure as suitable for starting most KANTHAL SUPER furnaces.

Step-down transformer and on/off control.

Open the furnace door slightly and switch on the starting voltage (1/3 or 1/4 of operating voltage) for the first drying-out period at 100-200 °C (210-390 °F).

Switch over to an intermediate voltage (2/3 or 1/2 of operating voltage). This must be done quickly in order to avoid too much reduction in element temperature and the resulting high current surges which may cause damage.

Allow the furnace door to remain slightly open for ventilation to continue while the furnace temperature rises gradually to 800 °C (1470 °F). When the furnace has reached this temperature, close the furnace door and allow the furnace to run up to full temperature at operating voltage.

10

Thyristor control.

When thyristor control is used, the remarks regarding operating voltage do not apply. It is advisable to reduce the current limit during the drying-out period. Otherwise, the same considerations apply as with a furnace with step-down transformer and on/off control.

For KANTHAL SUPER elements it is advantageous if they are allowed to work at an element temperature of at least 1500 °C (2730 °F) for one half to one hour as part of the initial start-up procedure.

Naturally, these basic instructions are not applicable to all furnaces. On large furnaces it is often advisable to dry out the brickwork by means of a separate source of heat before installing the KANTHAL SUPER elements.

Replacement of elements

One of the greatest advantages of KANTHAL SUPER elements is that a defective element can easily be replaced without the furnace having to be cooled down. Vertically mounted elements are replaced as follows:

After having located the defective element, unbolt the contacts from the busbars and remove the ceramic fibre around the upper part of the passage brick, after which the element and the passage brick may be lifted out. A previously assembled unit consisting of a new element complete with passage brick and element holders now should be inserted through the hole in the furnace roof.

The contacts which have been removed from the damaged element can be used again providing that they are undamaged. If the contact surfaces are oxidized or damaged to such an extent that they cannot be restored to a serviceable condition, they should be replaced.

Temperature control

The type of thermocouple used for temperature control depends on the furnace temperature. Type K has good stability to 1200 °C (2190 °F) and can be used in many heat treating furnaces. Temperature measuring above 1200 °C (2190 °F) is usually performed with thermocouples made of platinum-platinum/rhodium.

Thermocouples age faster the higher the furnace temperature is. In Pt-Pt/Rh thermocouples there is a structural change in the platinum and diffusion of rhodium occurs at the junction. Problems with temperature corrosion and overheated KANTHAL SUPER elements are often related to ageing thermocouples.

By alloying the platinum with rhodium the usable temperature increases. A high content of rhodium in both shanks gives the highest permissible furnace temperature.

When the rhodium content is increased, the EMF (electromotive force) decreases and this affects the accuracy of the measurement. When thermocouples are utilized at the maximum classifying temperatures, it is important to check the EMF frequently in order to avoid increased furnace temperature due to the ageing. In high temperature furnaces with KANTHAL SUPER 1900 elements operating at furnace temperatures above 1750 °C (3180 °F), using Pt/20% Rh - Pt/40% Rh, it has been found that the EMF can have decreased significantly after only 4-5 hours at furnace temperature. By the time this has occurred, the thermocouple has become more stable and the change is slower with time. This thermocouple has a low thermoelectric output and small changes can lead to large variations in the furnace temperature and element temperature with subsequent element problems.

For high temperature furnaces we recommend two thermocouple positions close to each other in the roof. One thermocouple for the controller and the SCR, the other to check the operating thermocouple and the actual furnace temperature. It is important that the thermocouple for checking is exposed to the furnace temperature only when the checks are being carried out.

Standard platinum-platinum/rhodium thermocouples

	Max. service temperature			
	Continuous		Intermittent	
	°C	°F	°C	°F
Pt/Pt 10 Rh, Type S	1400	2550	1650	3000
Pt/Pt 13 Rh, Type R	1400	2550	1650	3000
Pt 6 Rh/Pt 30 Rh, Type B	1500	2730	1800	3270
Pt 20 Rh/Pt 40 Rh,	1600	2910	1800	3270

Safety precautions

Use dark glasses when observing glowing KANTHAL SUPER elements. The eyes are subjected to great strain when observing temperatures above 1400 °C (2550 °F).

KANTHAL SUPER elements which have been operating for a long time at high temperature and have then cooled down sometimes have internal stresses which cause the glaze to splinter into small fragments. There have been instances where elements which have been cold for several days have emitted a shower of fine glaze particles when touched.

Always use eye protection even when handling cooled down KANTHAL SUPER elements.

Fig. 70 KANTHAL SUPER furnace for ingot heating.



Accessories

Element size 3/6 mm and 4/9 mm

(All dimensions in mm)

Contact straps

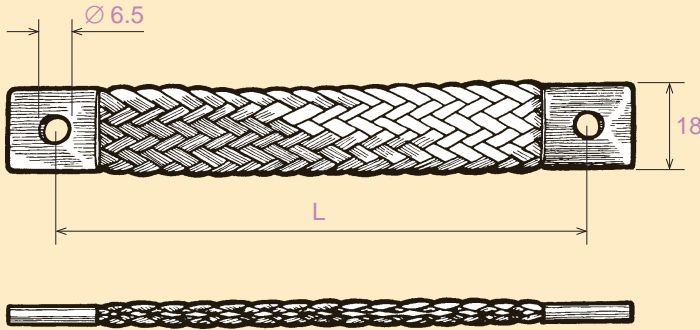

Type 5826

Lengths (L):
100, 150, 200

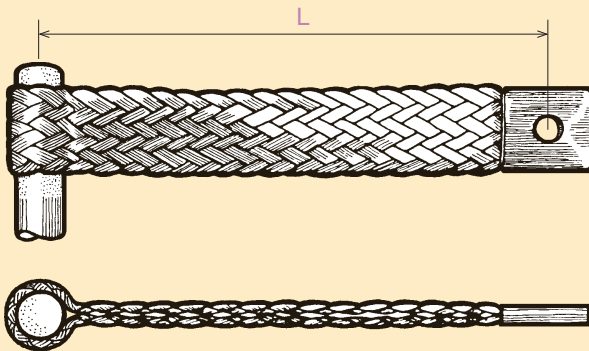

Type 5827

Lengths (L):
75, 100, 150, 200

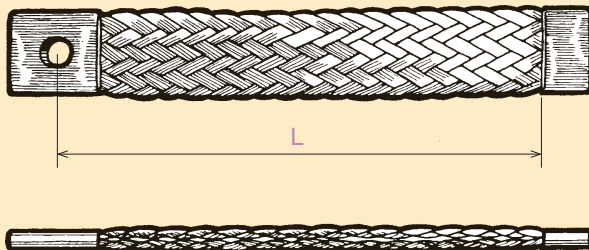

Type 5828

Lengths (L): 75,
100, 150, 200

11

Type 5829

Lengths (L):
75, 100, 150, 200
Spring clips to be
used at both ends.

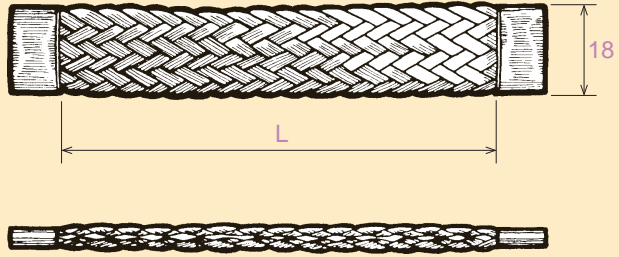

Type 10434

for element
size 3/6 mm

Type 10435

for element
size 4/9 mm

Spring clips

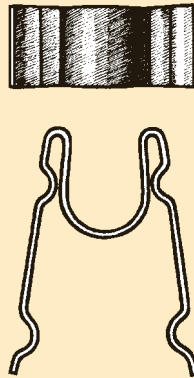

Type 5830

Element holder

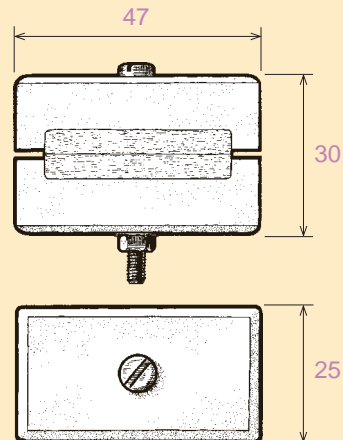

Single-shank holders

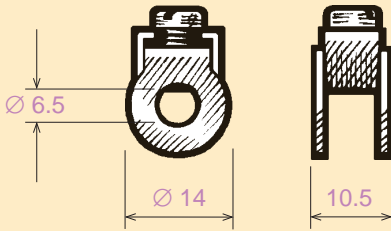

Type 10421

for element size 3/6 mm

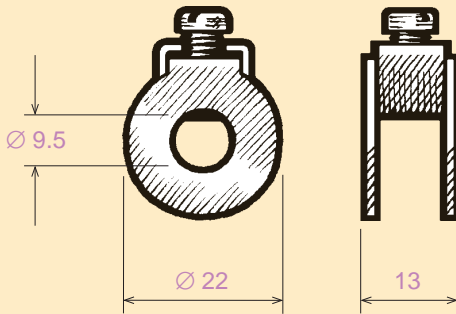

Type 10424

for element size 4/9 mm

**Element size 6/12 mm
Contact straps**

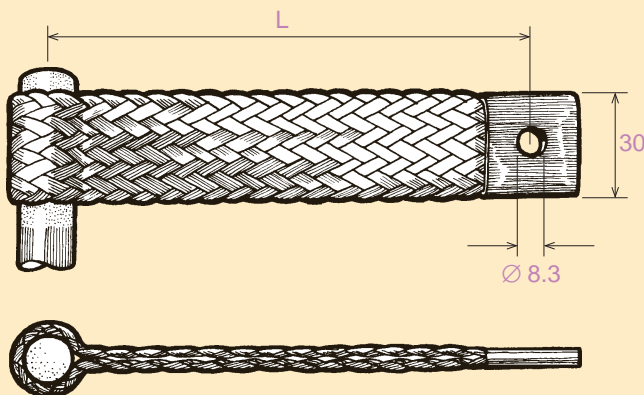

Type 5766

Lengths (L):
80, 100, 150, 200,
250, 300

11

Type 3579

Lengths (L):
80, 100, 150, 200,
250, 300

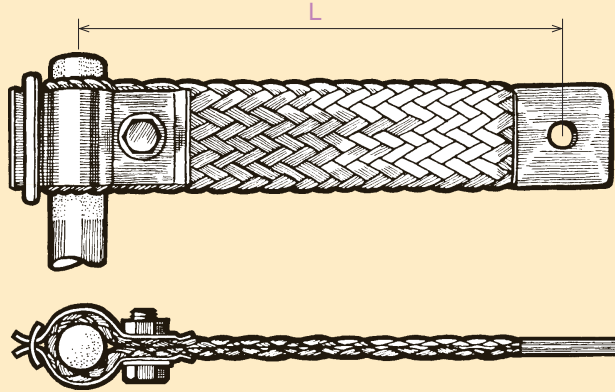

Type 5768

Lengths (L): 150
200, 250, 300
Note: two pcs per
shank for 9/18

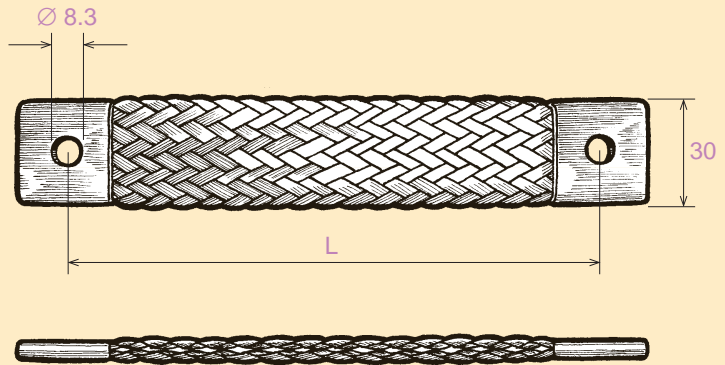

Type 5758

Contact clamp

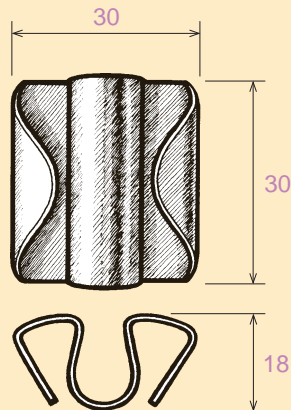

Expansion tool for clamps

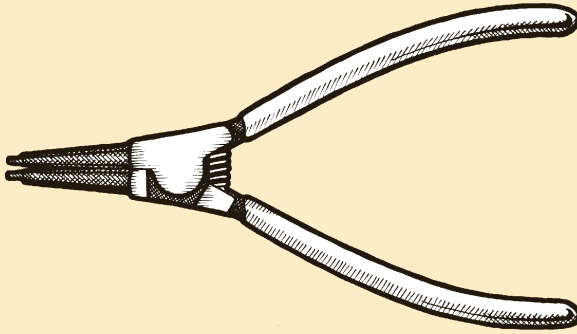

Type 21690

Single-shank holders

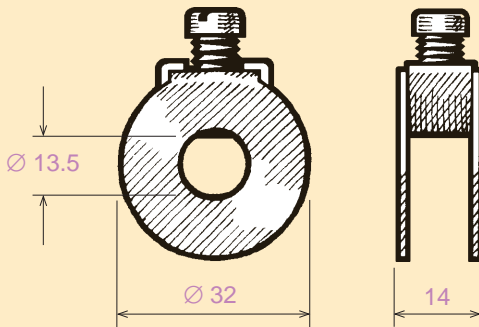

Type 6248

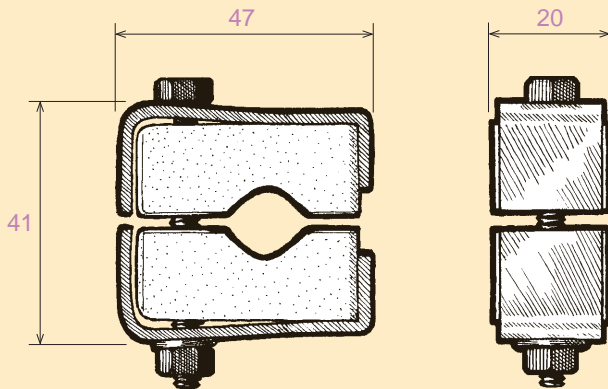

Type 5778

11

Type 5776

a = 40, 45, 50,
55, 60

Two-shank holder

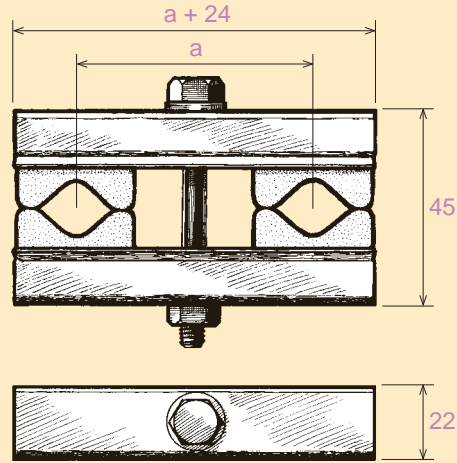

Element size 9/18 mm

Contact straps

Type 3801

Lengths (L):
100, 150, 200,
250, 300

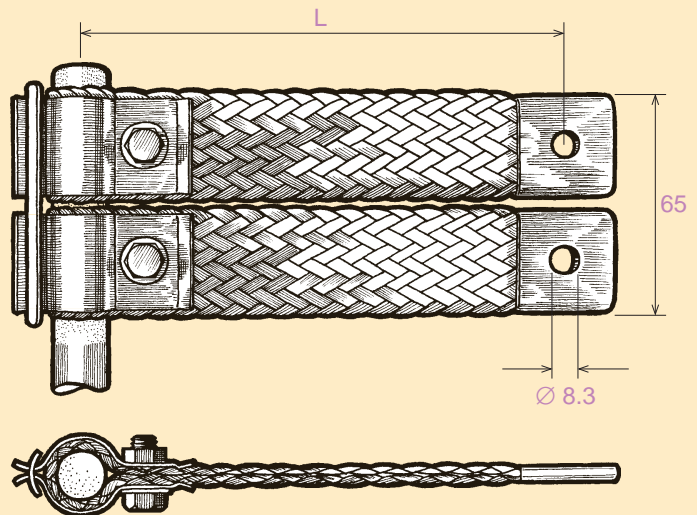

Single-shank holders

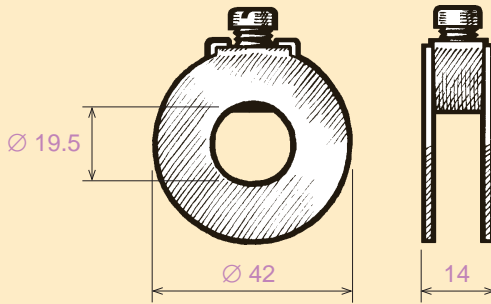

Type 6249

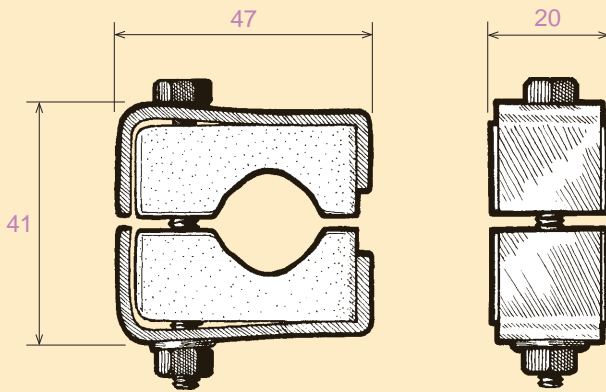

Type 5779

Two-shank holders

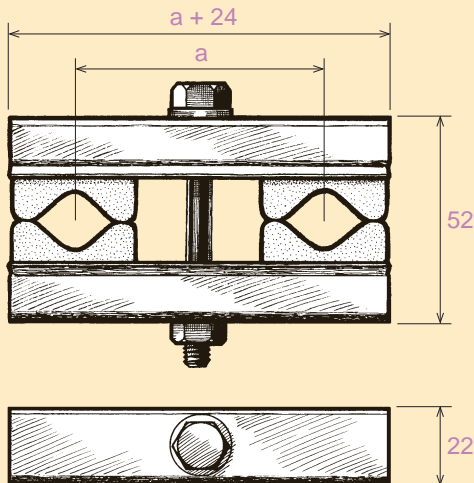

Type 5776

$a = 40, 45, 50, 55, 60$

11

Type 5777

a = 80 and 150
for element
size 6/12 also

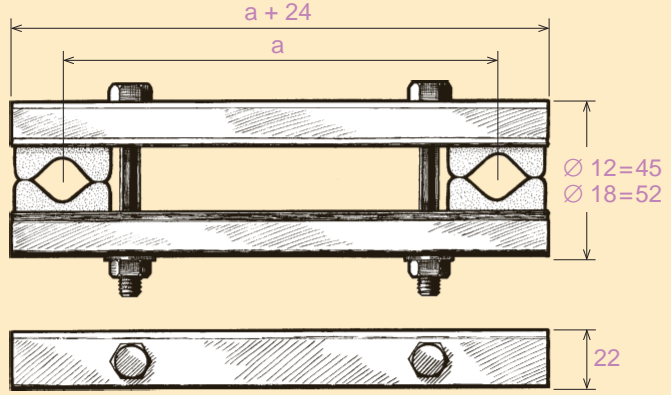

Element size 12/24mm
Contact straps

Type 10432

Lengths (L):
150, 200, 250, 300
Note: Two per
shank

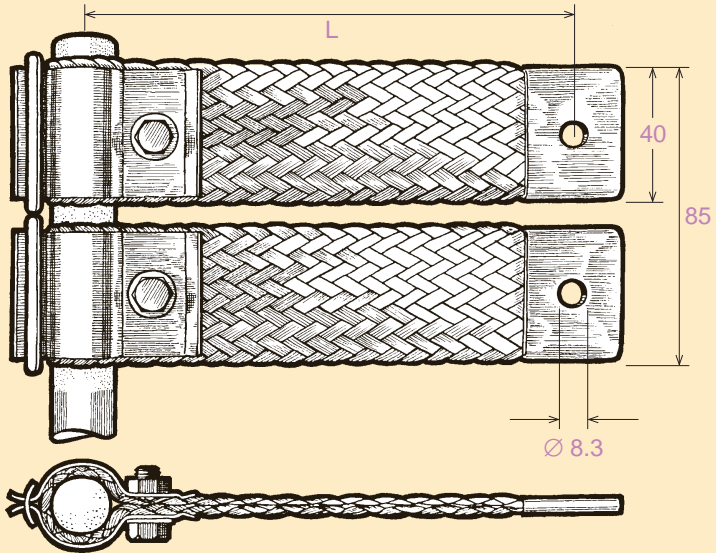

Type 10439

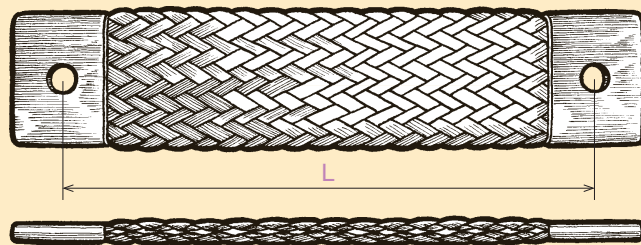

Single-shank holder

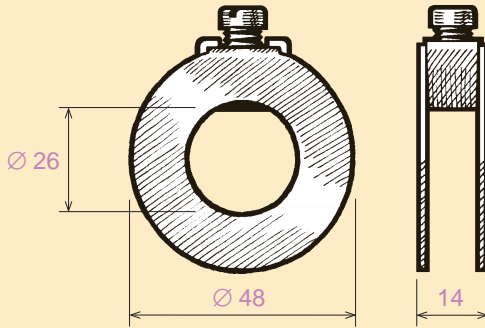

Type 10433

Two-shank holders

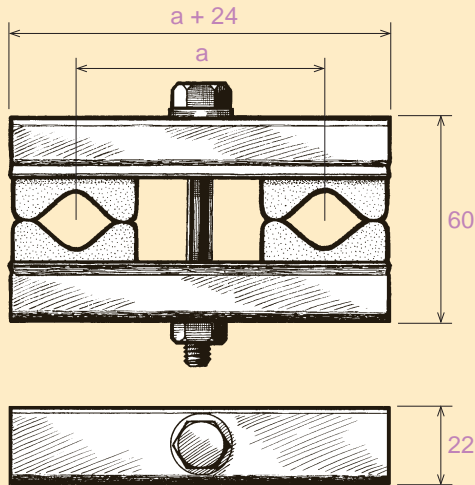

Type 10437

$a = 60$

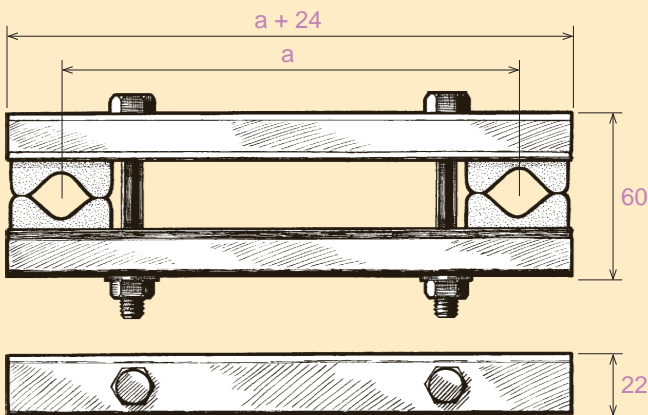

Type 10438

$a = 80$

11

Standard anchor system

Type 5987

Element holder
Standard design

Anchor systems

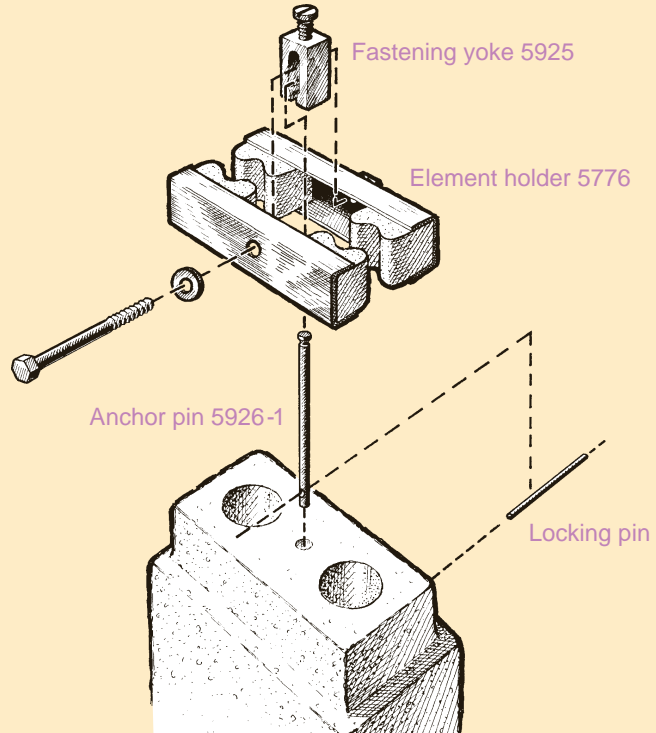

Air cooled anchor system

Type 5927

Element holder
with air nozzle for
KANTHAL SUPER
9/18 mm a = 60

Type 6031

Element holder for
KANTHAL SUPER
6/12 mm a = 50

Type 6033

Element holder for
KANTHAL SUPER
6/12 mm a = 40

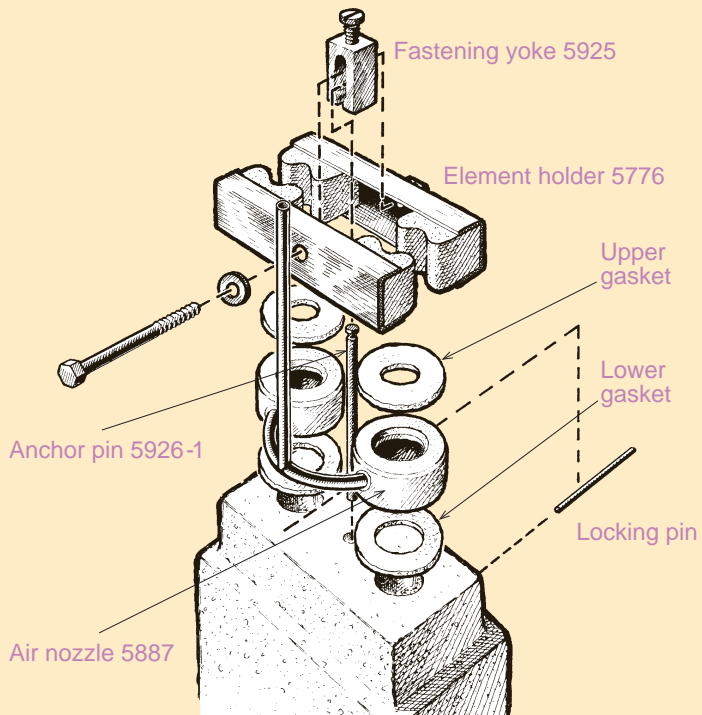

Sealed element anchor system

Type 5965

Element holder with sealed terminal lead through for KANTHAL Super 9/18 mm a = 60

Type 6037

Element holder with sealed terminal lead through for KANTHAL Super 6/12 mm a = 50

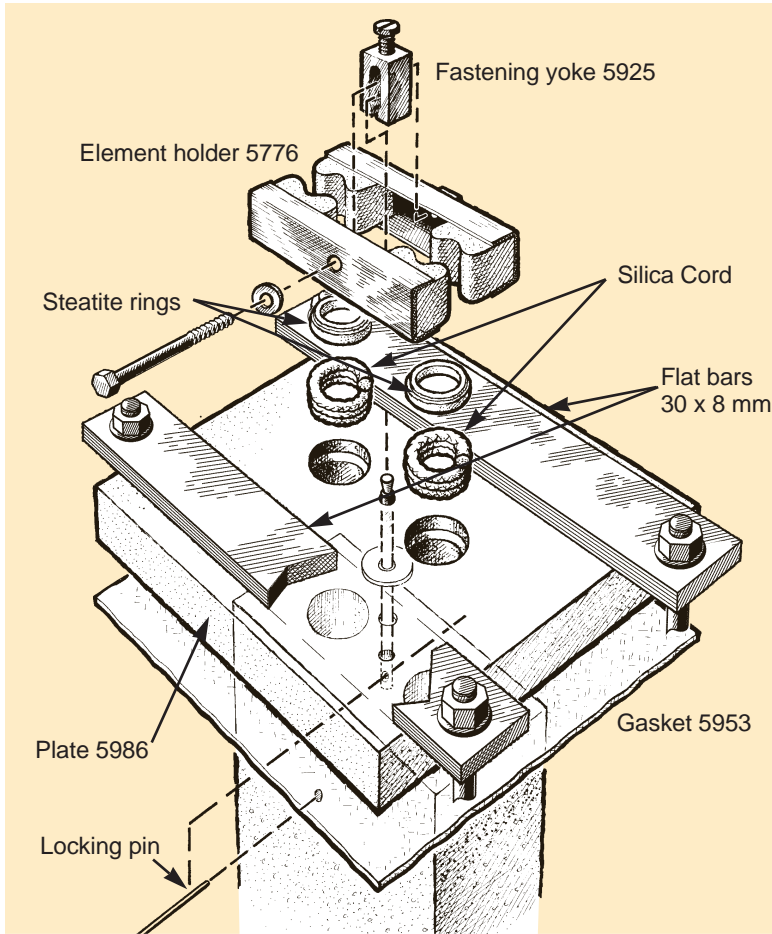

Graphite alternative

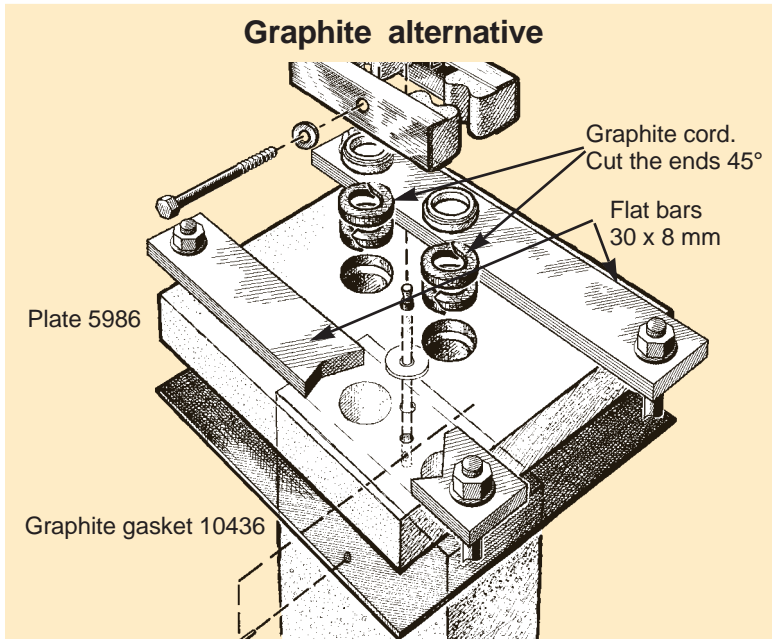

11

**For anchor systems.
Sealed design.**

Passage bricks

Note: Under certain conditions, long passage bricks may result in excessive temperatures on the terminals, unless special precautions are taken when designing the furnace.

Type No.	Grade	A	B	C	a	d	Element size
6038-1	28	115	64	229	50	15	6/12
5984-1		115	64	229	60	23	9/18
5984-2		115	76	229	60	23	
5984-3	152	76	305	60	23		

Type 6038
for 6/12 mm

Type 5984
for 9/18 mm

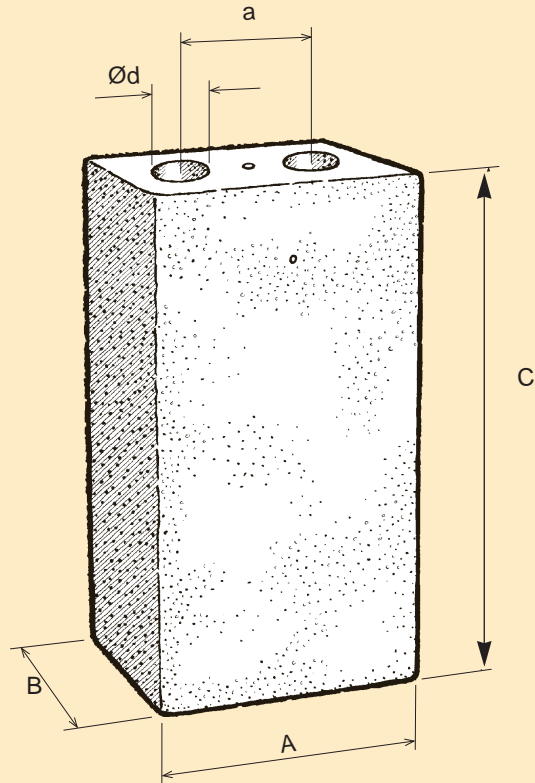

Type No.	Grade	A	B	C	a	d	D	Element size
6036-1,-3,-6	G28,30,33	115	64	229	40	15	25	6/12
6036-9,-4,-8		115	64	229	45	15	25	
6036-2,-5,-7		115	64	229	50	15	25	
5985-1,-4,-8	G28,30,33	115	64	229	60	23	35	9/18
5985-2,-5,-10		115	76	229	60	23	35	
5985-3,-6,-11		152	76	305	60	23	35	
10943-1,-4,-7	G28,30,33	115	64	229	60	30	40	12/24
10943-2,-5,-8		115	76	229	60	30	40	
10943-3,-6,-9		152	76	305	80	30	40	

For anchor systems. Standard design.

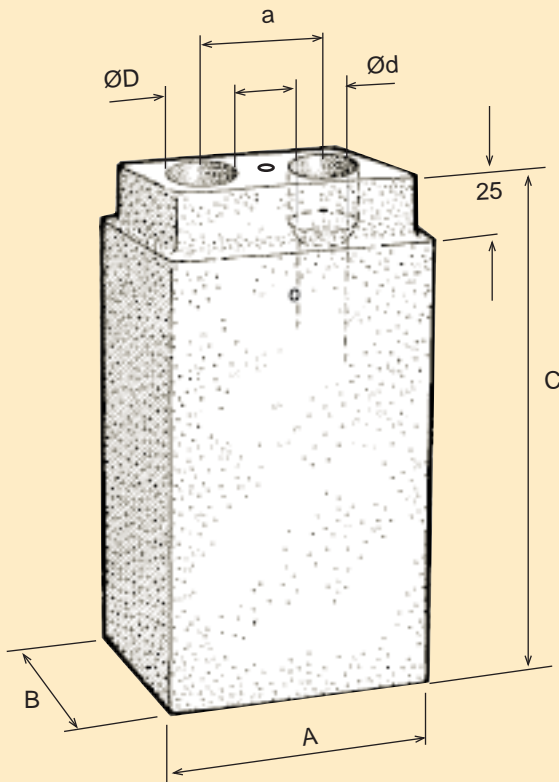

Type 6036
for 6/12 mm

Type 5985
for 9/18 mm

Type 10943
for 12/24

11

**For anchor systems.
Air cooled design.**

Type No.	Grade	A	B	C	a	d	D	Element size
6035-1,-3,-6	G28,30,33	115	64	229	40	15	25	6/12
6035-,-4,-7		115	64	229	45	15	25	
6035-2,-5,-8		115	64	229	50	15	25	
5930-1,-4,-7	G28,30,33	115	64	229	60	23	35	9/18
5930-2,-5,-8		115	76	229	60	23	35	
5930-3,-6,-9		152	76	305	60	23	35	

Type 6035
for 6/12 mm

Type 5930
for 9/18 mm

for 12/24 mm

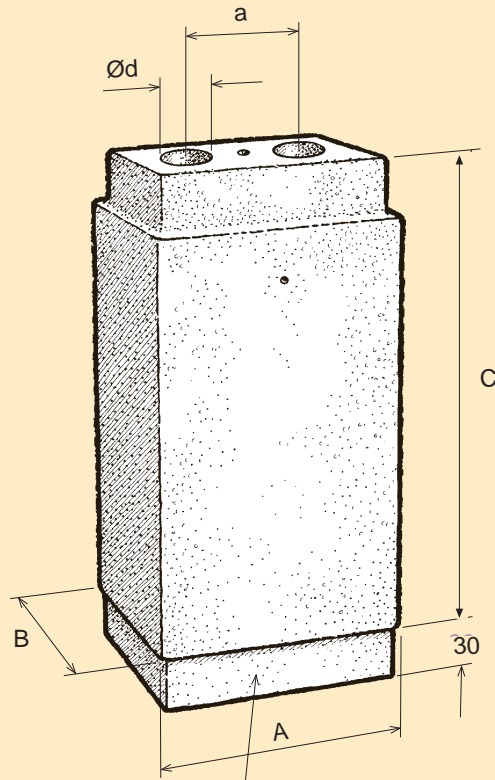

Bottom plate: ALFRAX coated grade 33

Other Accessories

Element size	6/12	9/18
D	20	27
d	13	19

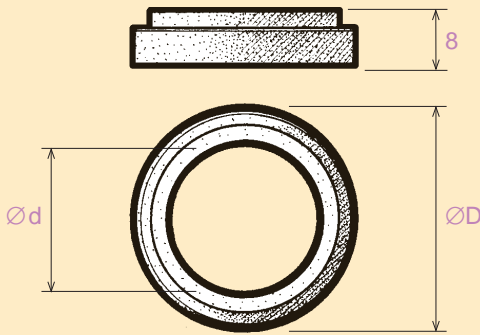

Element size	6/12	9/18
Length of silica cord	2 x 180	2 x 230
Length of graphite cord	4 x 60	4 x 80

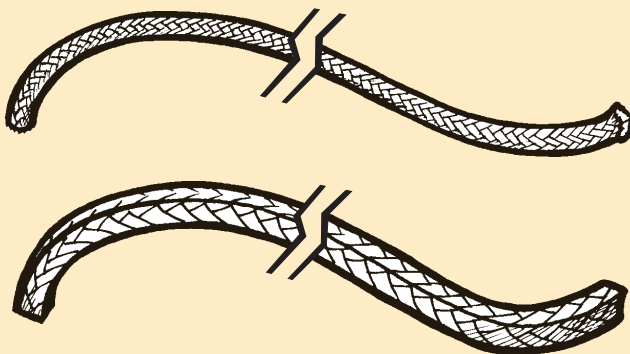

Steatite rings

11

Silica cord and graphite cord

11

Plates

Type	A	B	a	d	D
5986-1	150	150	60	20	28
5986-2	160	160	60	20	28
5986-3	180	180	60	20	28
5986-4	160	200	60	20	28
5986-5	130	180	60	20	28
5986-10	150	150	50	13	21

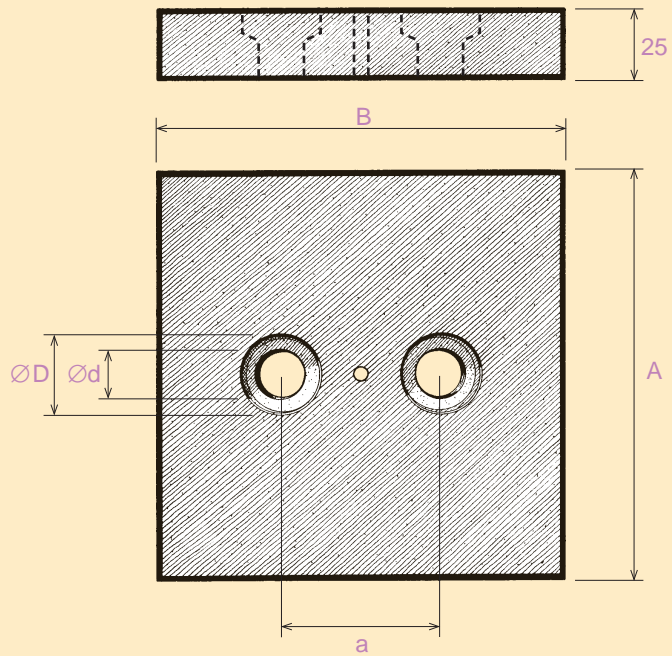

Gasket for plates

Graphite	Ceramic fibre	A	B	a	d
10436-1	5953-1	150	150	60	18
10436-2	5953-2	160	160	60	18
10436-3	5953-3	180	180	60	18
10436-4	5953-4	160	200	60	18
10436-5	5953-5	130	180	60	18
10436-10	5953-10	150	150	50	12

10436-1-5 d = 30 mm
 10436-10 d = 24 mm

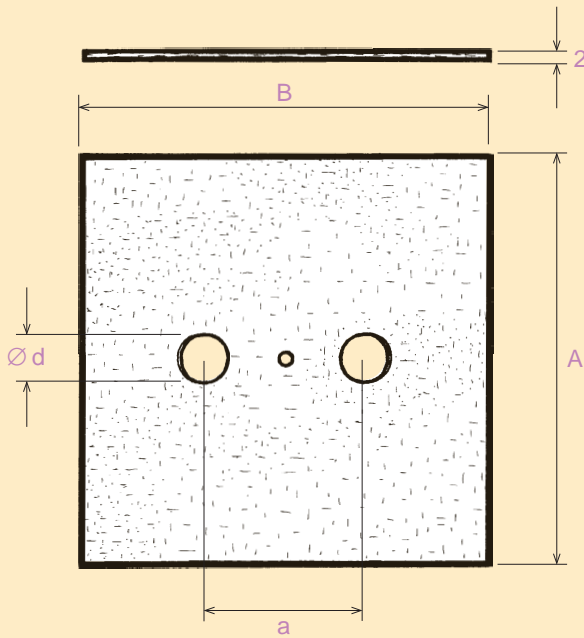

11

Air nozzles

Type	Element size	a	D	d
5887-A	6/12	40	36	13.5
5887-B	6/12	50	36	13.5
5887-C	9/18	60	42	19.5

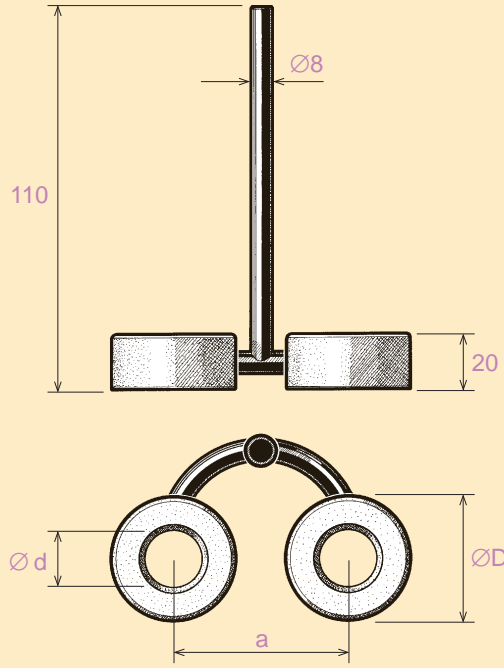

Gaskets for air nozzles

Element size	6/12		9/18	
	d	D	d	D
Upper gasket	11	32	17	38
Lower gasket	16	36	22	42

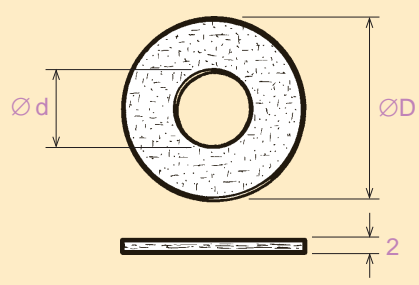

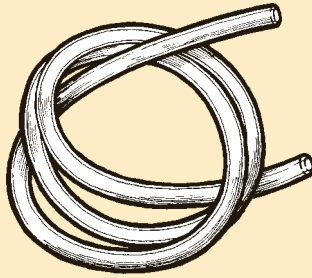

Silicon rubber hose

For connection to air nozzles

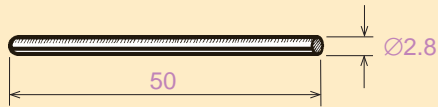

Locking pin

Type	Anchor system
5926-1	Standard and air cooled
5926-2	Sealed ¹⁾
5926-3	Sealed
5926-4	Air cooled ²⁾

Anchor pins

1) Without locking pin.
2) Element size 6/12 mm and distance between shanks (a) = 40 mm

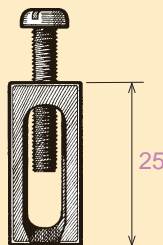
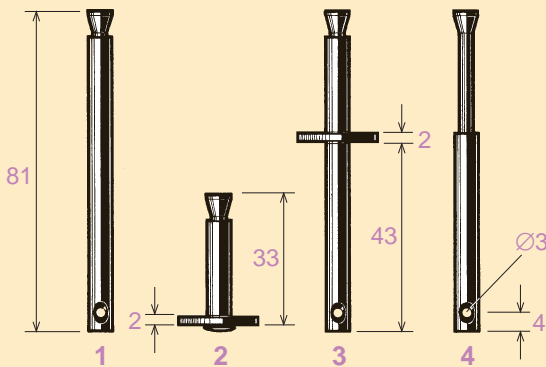

Fastening yoke Type 5925



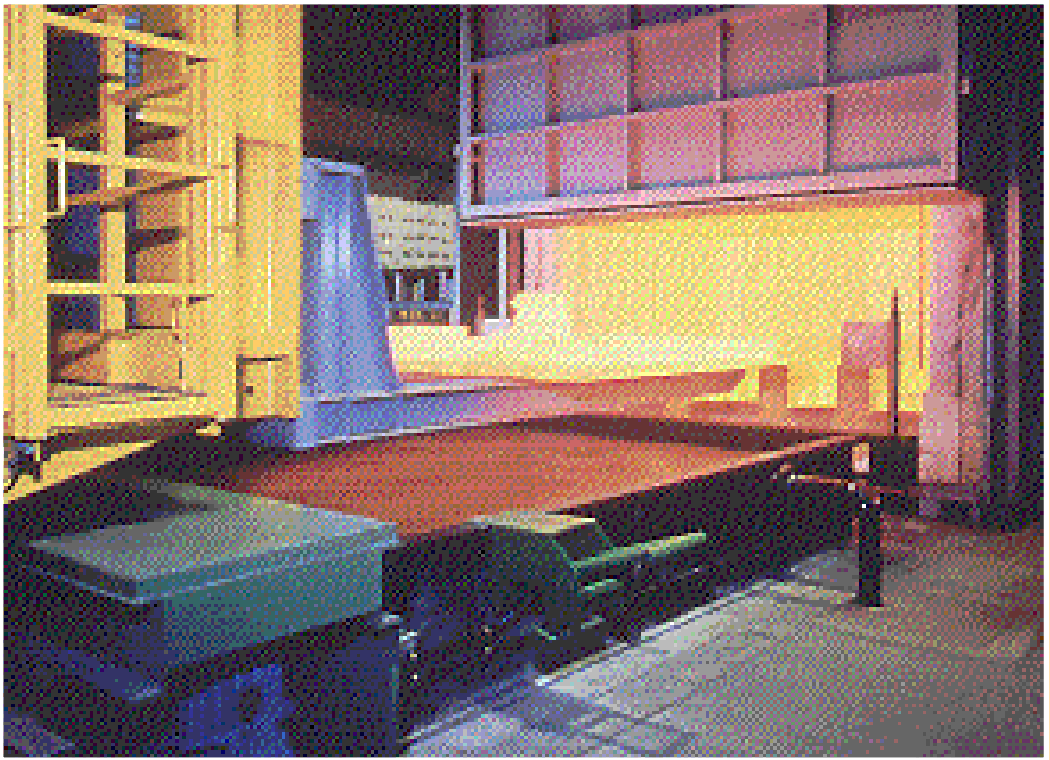
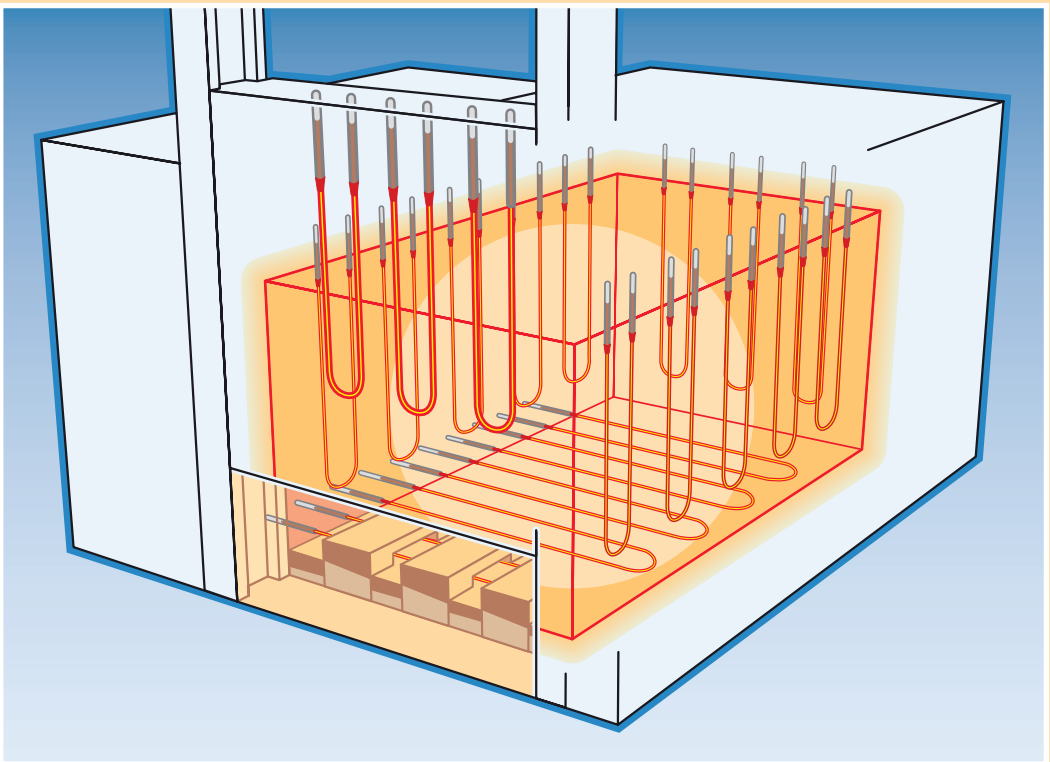

Fig. 71 Automatic hardening line heated with KANTHAL SUPER elements located in the floor, in the door and along the three walls.



Troubleshooting

KANTHAL SUPER is a long lasting heating element due to its low ageing rate. Installed according to our recommendations, their life is to most operator's satisfaction.

Element life is limited due to several reasons, but the major reason for failure is rarely due to material faults or workmanship.

The design of the element lead through is critical for optimum element life.

The most common reasons for element failure, which we have seen have been due to:

Careless handling

- Handling of element packages by the carriers whilst in transit
- Handling of elements by the customer after being removed from the package

Mechanical damage

- Breakage of elements after being installed in the furnace e.g. bumping into an element with a wrench or elbow when carrying out repair work inside a furnace. Also, breakages when elements are removed before relining a furnace.

Mechanical stress

- All roof suspended elements should be hung freely to allow unrestricted movement of the element shanks during expansion and contraction due to electro-magnetic forces and thermal expansion.
- Any binding-sticking of the elements during thermal cycling can result in mechanical and thermal stresses. If this is the case, the element will typically break around the fusion welded joint between the heating zone and terminals.
- The contact straps should be long enough so that no stresses are transferred to the elements. If there is sufficient space available, it is preferable to use busbars or terminal posts for series connecting elements as the risk of damaging adjacent elements will be reduced when replacing individual elements.

Chemical attack

- Compounds and gases, which may have a detrimental effect on KANTHAL SUPER material is covered in chapter 2.

Overheated elements

- When the element temperature exceeds the limit for each of the three qualities, the silica in the material starts to boil. The MoSi_2 depletes through evaporation of the silica and the hot zone shows signs

of surface cracking and is pitted in appearance. The effect is the same if part of the hot zone is restricted to radiate freely. If one side of the hot zone is too close either to the furnace wall or some other restriction, this side can show signs of overheating.

Overheated contacts

Either one or a combination of the following items can cause too high a temperature on the contacts:

- Chimney effect
- Terminal length protruding outside the furnace being too short
- Contacts become loose
- Poor roof insulation (insufficient thickness, quality, cracking or degradation)
- Poor ventilation over the contacts

Chimney effect

The terminals should be sealed at the cold face with ceramic fibre to prevent convective and radiant heat losses (elements must still be able to move freely).

Terminal length too short

It is quite common to see installations where the contacts are very close to the holders.

Loose contacts

Can cause thermal shock breakages due to sparking between contact and terminal end. Symptoms: partly melted contacts, thermal cracking of terminal end due to arcing.

When low temperature oxidation (pest) occurs underneath the aluminizing, the temperature has been far too high. The effect is the same as with loose contacts.

12

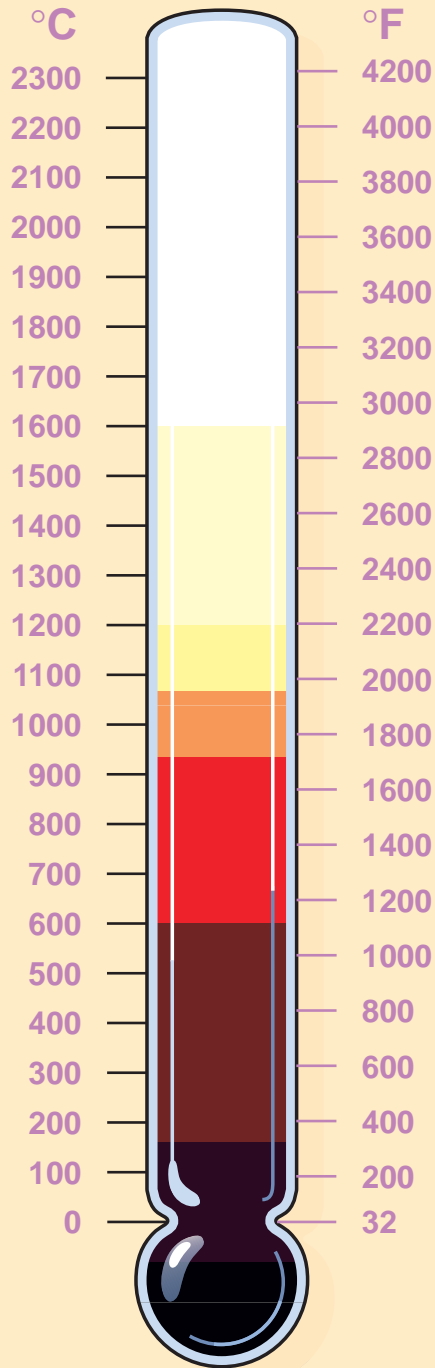

Fig. 72 Element temperature.

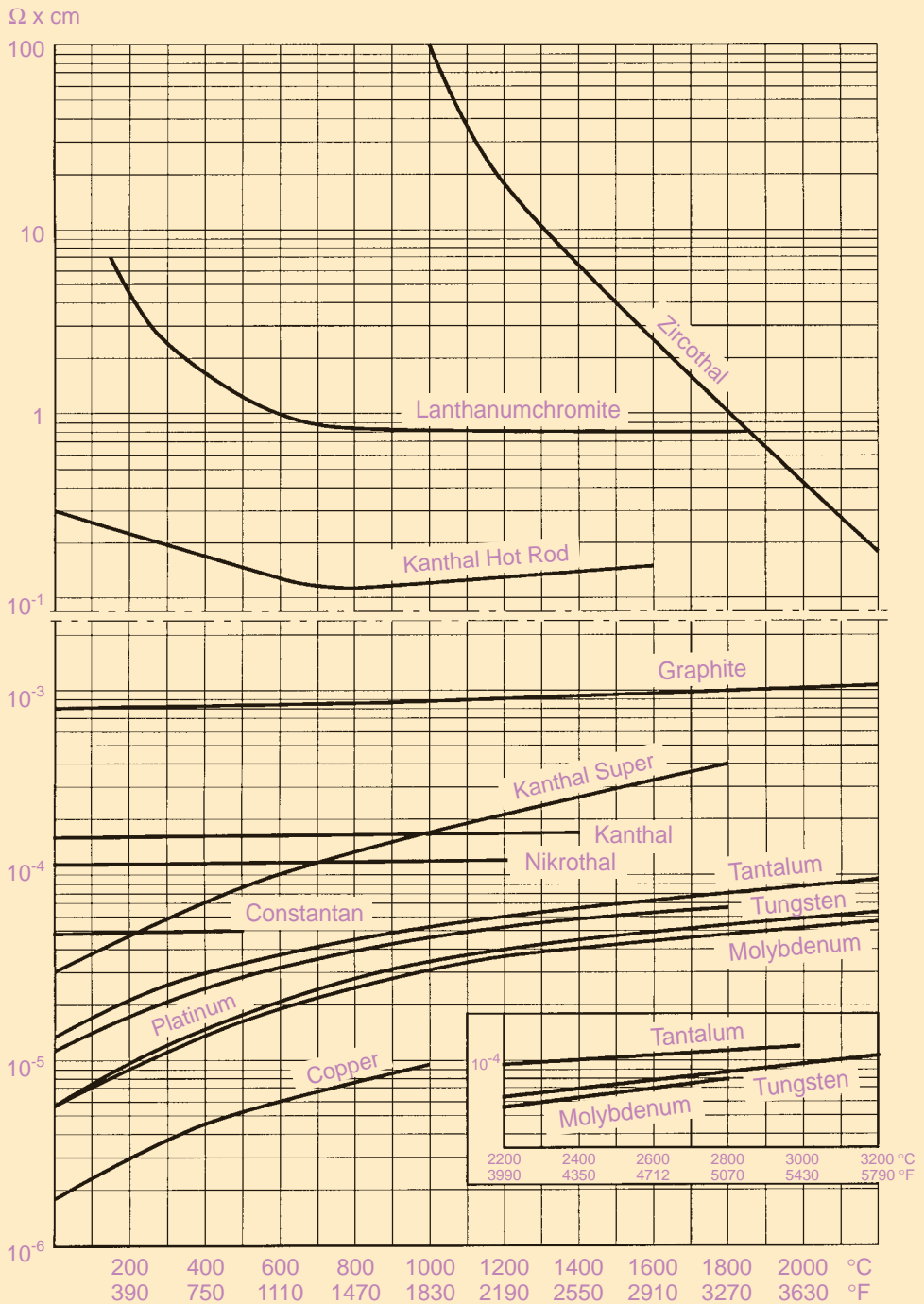

Fig. 73 Resistivity ($\Omega \times \text{cm}$) as a function of temperature for some resistor materials and for copper.

Gases	Chemical formula	Molecular weight	Liquid state			Gaseous state		
			Density at 20 °C kg/l	Boiling point (1013 bar) °C	Heat of evaporation kJ/kg	Density (15°C, 1 bar) kg/m ³	Specific heat cp kJ/kg x°C	Thermal conductivity μW/cm . °C
Ammonium	NH ₃	17.03	0.591	-34.4	1370.8	0.72	2.12 (25°C)	215 (0°C)
Argon	Ar	39.95	—	-185.9	163.8	1.67	0.52 (15°C)	162 (0°C)
n-Butane	C ₄ H ₁₀	58.12	0.579	-0.5	384.8	2.51	1.68 (15°C)	135 (0°C)
Helium	He	4.00	—	-268.9	20.3	0.17	5.19 (15°C)	1484 (0°C)
Hydrogen	H ₂	2.02	—	-252.8	446.0	0.084	14.26 (15°C)	1682 (0°C)
Carbon dioxide	CO ₂	44.01	0.775	-78.4	348.3	1.85	0.85 (15°C)	162 (25°C)
Carbon monoxide	CO	28.01	—	-191.5	215.7	1.17	1.04 (15°C)	248 (25°C)
Air		28.96	—	—	—	1.21	1.01	255
Methane	CH ₄	16.04	—	-161.5	510.0	0.671	219 (15°C)	305 (0°C)
Methanol	CH ₃ OH	32.04	0.739	65	1109	1.34	1.34 (0°C)	140 (0°C)
Nitrogen	N ₂	28.01	—	-195.8	198.9	1.17	1.04 (15°C)	241 (0°C)
Propane	C ₃ H ₈	44.10	0.501	-42.1	425.6	1.88	1.65 (15°C)	146 (0°C)
Propene	C ₃ H ₆	42.08	0.505	-47.7	438.0	1.78	1.50 (15°C)	199 (25°C)

Table 8 Physical data — Gases.

Dew point °C	Percentage by volume	g/Nm ³	Dew point °C	Percentage by volume	g/Nm ³	Dew point °C	Percentage by volume	g/Nm ³
-100	0.00000139	0.0000111	-20	0.102	0.816	+1	0.649	5.21
-90	0.00000955	0.0000767	-19	0.112	0.899	+2	0.696	5.59
-80	0.0000540	0.000343	-18	0.123	0.989	+3	0.750	6.02
-70	0.000258	0.00207	-17	0.135	1.09	+4	0.803	6.45
-60	0.00107	0.00857	-16	0.148	1.19	+5	0.861	6.91
-55	0.00207	0.0166	-15	0.163	1.31	+6	0.922	7.41
-50	0.00388	0.0312	-14	0.179	1.43	+7	0.922	7.41
-48	0.00496	0.0399	-13	0.196	1.57	+8	1.06	8.51
-46	0.00631	0.0507	-12	0.214	1.72	+9	1.13	9.10
-44	0.00800	0.0642	-11	0.234	1.88	+10	1.21	9.74
-42	0.0102	0.0816	-10	0.256	2.06	+11	1.29	10.4
-40	0.0127	0.102	-9	0.280	2.25	+12	1.38	11.1
-38	0.0159	0.127	-8	0.305	2.45	+13	1.48	11.9
-36	0.0198	0.159	-7	0.333	2.68	+14	1.58	11.9
-34	0.0246	0.197	-6	0.363	2.92	+15	1.68	13.5
-32	0.0304	0.244	-5	0.396	3.18	+16	1.79	14.4
-30	0.0375	0.301	-4	0.431	3.456	+17	1.91	15.4
-28	0.0461	0.371	-3	0.469	3.77	+18	2.0	16.4
-26	0.0565	0.454	-2	0.510	4.10	+19	2.17	17.4
-24	0.0690	0.554	-1	0.555	4.46	+20	2.31	18.5
-22	0.0840	0.675	0	0.602	4.84			

Table 9 Content of water — Gases.

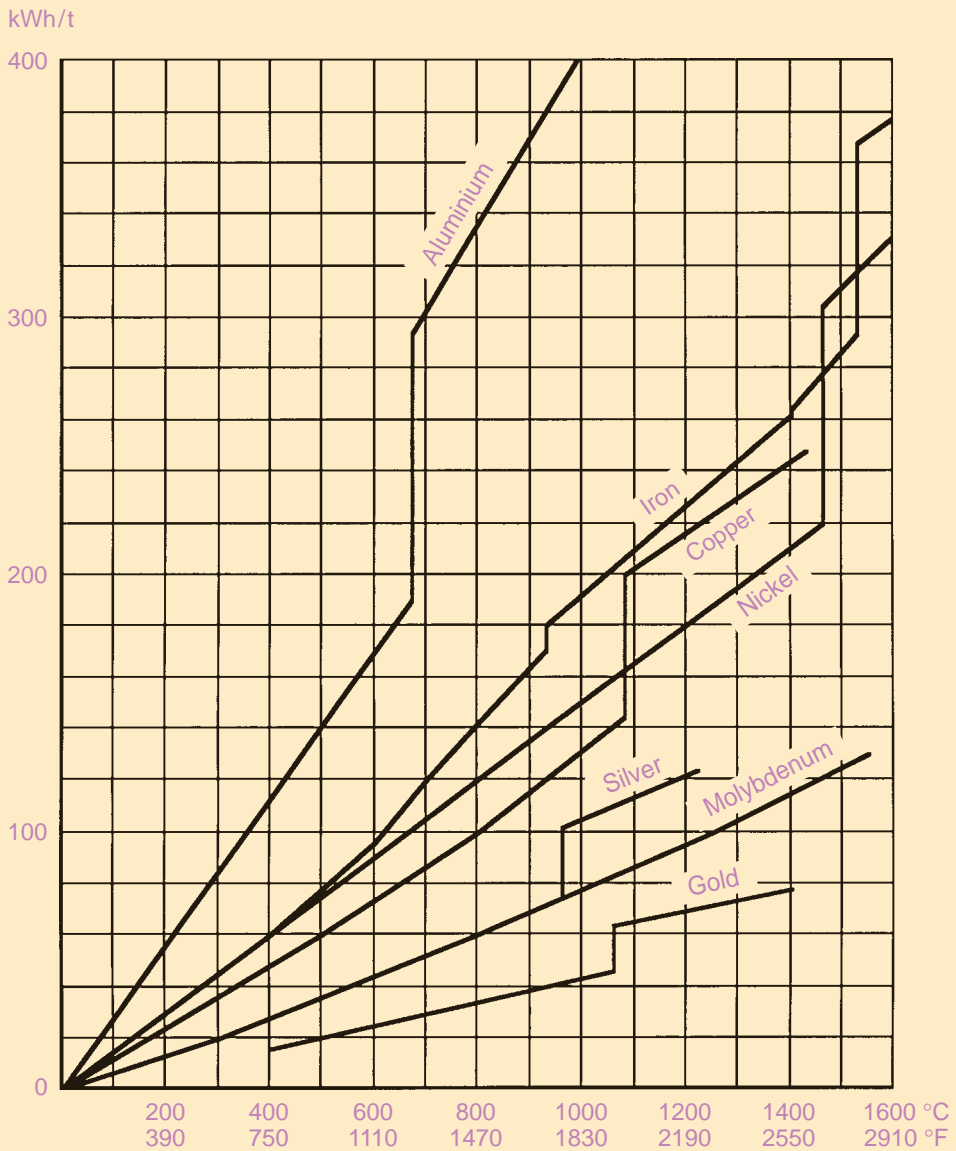

Fig.74 Average theoretical heat storage in kWh per metric tonne for some common metals.

Element	Symbol	Molecular weight	Specific gravity g/cm ³	Melting point °C	Boiling point 760 Torr °C	Heat of fusion		Specific heat capacity at 20°C		Thermal conductivity at 20°C			Coefficient of linear expansion 10 ⁶ /°C	Specific electrical resistance R _a ·10 ² at 20°C Ω mm ² m
						kcal	kWh	cal	Wh	cal	kcal	W		
						kg	kg·10 ³	g·°C	g·°C·10 ³	cm·s·°C	m·h·°C	cm·°C		
Aluminium	Al	26.97	2.70	660.1	2500	85	98.82	0.214	0.2488	0.55	198.0	2.3117	23.1	2.86
Antimony	Sb	121.75	6.69	630.5	1635	38.9	45.23	0.0496	0.0577	0.55	198.00	2.3117	10.8	38.6
Bismuth	Bi	208.90	9.8	271.3	1560	14.1	16.393	0.0295	0.0343	0.02	7.2	0.0837	12.1	125
Cadmium	Cd	112.4	8.64	320.9	765	12.9	14.997	0.0552	0.0642	0.23	82.8	0.9625	31	7.7
Caesium	Cs	132.9	1.87	28.5	690	—	—	—	—	—	—	—	97	19
Calcium	Ca	40.08	1.54	850.0	1439	78	90.683	0.155	0.1802	—	—	—	22	4.3
Chromium	Cr	52.0	7.1	1920	2327	70	81.382	0.105	0.1221	0.165	59.4	0.8605	8.5	15
Cobalt	Co	58.93	8.8	1492	3185	64	74.406	0.093	0.1080	0.17	61.2	0.7115	11	5.06
Copper	Cu	63.54	8.93	1083	2595	51	59.293	0.093	0.1080	0.94	338.4	3.9339	16.5	1.75
Gallium	Ga	69.72	5.9	29.78	2064	19.1	22.206	0.080	0.093	—	—	—	18	39.5
Germanium*	Ge	72.59	5.32	958.5	2700	—	—	0.0727	0.0845	—	—	—	6	8.9·10 ⁴
Gold	Au	196.97	19.29	1063	2960	15.9	18.485	0.0307	0.0357	0.75	270	3.1387	14.2	2.2
Hafnium	Hf	178.49	13.3	2230	>3200	—	—	0.033	0.0384	—	—	—	—	30
Indium	In	114.82	7.25	156.7	>1450	—	—	0.056	0.0651	—	—	—	5.6	8.2
Iridium	Ir	192.2	22.4	2442	4800	28	32.553	0.032	0.0372	0.14	50.4	0.5859	6.58	4.58
Iron	Fe	55.85	7.876	1535	2730	49.4	57.432	0.108	0.1256	0.21	75.6	0.8788	11.5	8.7
Lead	Pb	207.19	11.34	327.4	1750	5.7	6.63	0.0309	0.0359	0.084	30.24	0.3515	31.3	20.7
Lanthanum	La	138.91	6.15	885	1800	—	—	0.044	0.0512	—	—	—	—	—
Lithium	Li	6.94	0.534	186	1370	32.8	38.123	1.0	1.1626	0.16	57.6	0.6696	58	8.55
Magnesium	Mg	24.31	1.74	650	1107	46.5	54.061	0.243	0.2825	0.41	147.6	1.7158	26	4.18
Manganese	Mn	54.94	7.3	1247	2095	63.7	74.06	0.114	0.1325	0.12	43.2	0.5022	23	10.0
Mercury	Hg	200.59	13.65	-38.87	356.58	2.7	3.149	0.0333	0.0387	0.02	7.2	0.0837	—	94.07
Molybdenum	Mo	95.94	10.2	2610	4800	69.4	80.69	0.065	0.0756	0.34	122.4	1.4229	5.1	5.4
Nickel	Ni	58.71	8.9	1453	3177	73	84.870	0.1065	0.1238	0.21	75.6	0.8788	12.5	9.5
Niobium	Nb	92.06	8.57	1950	2900	—	—	0.0645	0.0750	—	—	—	7.1	13.0
Osmium	Os	190.20	22.5	2700	>5300	35	40.691	0.0310	0.0350	—	—	—	7.0	9.66
Palladium	Pd	106.4	11.97	1552	2800	36.3	42.202	0.058	0.0674	0.17	61.2	0.7115	10.6	10.88
Potassium	K	39.10	0.862	63.5	776	15.7	18.253	0.177	0.2058	0.23	82.8	0.9625	84	6.38
Platinum	Pt	195.1	21.45	1769	4300	27.2	31.623	0.032	0.0372	0.17	61.2	0.7115	8.94	9.8
Radium	Ra	226.05	5.0	700	1140	—	—	—	—	—	—	—	—	—
Rhodium	Rh	102.9	12.4	1960	>2500	52	60.452	0.0592	0.0688	0.21	75.6	0.877	9.0	4.3
Selenium*	Se	78.96	4.8	170	688	15.4	17.904	0.079	0.0918	—	—	—	37	12
Silver	Ag	107.87	10.5	960.5	1950	25	29.065	0.0559	0.0650	0.974	350.6	4.0762	18.7	1.5
Silicon*	Si	28.09	2.33	1440	2630	33.8	39.296	0.168	0.1953	—	—	—	7	10 ⁵
Sodium	Na	22.997	0.971	97.8	883	27.5	31.972	0.288	0.3348	0.33	118.8	1.3811	71	4.34
Tantalum	Ta	180.95	16.6	3000	4100	41.5	48.248	0.033	0.0384	0.13	46.8	0.5441	6.58	12.4
Tellurium	Te	127.61	6.24	452	1390	—	—	0.048	0.0558	—	—	—	17.2	6·10 ⁴
Thorium	Th	232.04	11.2	1845	3530	—	—	0.03	0.0349	—	—	—	11.1	12.0
Tin	Sn	118.69	7.28	231.9	2430	14.2	16.509	0.053	0.0616	0.15	54.0	0.6278	12.8	11.4
Titanium	Ti	47.9	4.35	1727	3200	—	—	0.146	0.1697	—	—	—	—	43.5
Tungsten	W	183.85	19.3	3380	6000	60	69.756	0.33	0.3837	0.31	111.6	1.2973	4.5	5.48
Uranium	U	238.03	18.7	1130	—	—	—	0.03	0.0349	—	—	—	—	30.6
Vanadium	V	50.94	6.0	1726	3000	—	—	0.12	0.1395	—	—	—	8.84	19
Zinc	Zn	65.37	7.13	419.5	906	26	30.228	0.092	0.1070	0.27	97.2	1.13	14.1	6.0
Zirconium	Zr	91.22	6.53	1860	2900	—	—	0.06	0.0697	—	—	—	14.3	41

12

Temperature Conversion Table

The numbers in the shaded area indicate the temperatures as read. The corresponding temperatures in Farenheit are given on the right and those in Celsius on the left.

°C	°F	°C	°F	°C	°F	°C	°F				
-17.8	0	32	16.1	61	141.8	154	310	590	488	910	1670
-17.2	1	33.8	16.7	62	143.6	160	320	608	493	920	1688
-16.7	2	35.6	17.2	63	145.4	166	330	626	499	930	1706
-16.1	3	37.4	17.8	64	147.2	171	340	644	504	940	1724
-15.6	4	39.2	18.3	65	149.0	177	350	662	510	950	1742
-15.0	5	41.0	18.9	66	150.8	182	360	680	516	960	1760
-14.4	6	42.8	19.4	67	152.6	188	370	698	521	970	1778
-13.9	7	44.6	20.0	68	154.4	193	380	716	527	980	1796
-13.3	8	46.4	20.6	69	156.2	199	390	734	532	990	1814
-12.8	9	48.2	21.1	70	158.0	204	400	752	538	1000	1832
-12.2	10	50.0	21.7	71	159.8	210	410	770	543	1010	1850
-11.7	11	51.8	22.2	72	161.1	216	420	788	549	1020	1868
-11.1	12	53.6	22.8	73	163.4	221	430	806	554	1030	1886
-10.6	13	55.4	23.3	74	165.2	227	440	824	560	1040	1904
-10.0	14	57.2	23.9	75	167.0	232	450	842	566	1050	1922
-9.44	15	59.0	24.4	76	168.8	238	460	860	571	1060	1940
-8.89	16	60.8	25.0	77	170.6	243	470	878	577	1070	1958
-8.33	17	62.6	25.6	78	172.4	249	480	896	582	1080	1976
-7.78	18	64.4	26.1	79	174.2	254	490	914	588	1090	1994
-7.22	19	66.2	26.7	80	176.0	260	500	932	593	1100	2012
-6.67	20	68.0	27.2	81	177.8	266	510	950	599	1110	2030
-6.11	21	69.8	27.8	82	179.6	271	520	968	604	1120	2048
-5.56	22	71.6	28.3	83	181.4	277	530	986	610	1130	2066
-5.00	23	73.4	28.9	84	183.2	282	540	1004	616	1140	2084
-4.44	24	75.2	29.4	85	185.0	288	550	1022	621	1150	2102
-3.89	25	77.0	30.0	86	186.8	293	560	1040	627	1160	2120
-3.33	26	78.8	30.6	87	188.6	299	570	1058	632	1170	2138
-2.78	27	80.6	31.1	88	190.4	304	580	1076	638	1180	2156
-2.22	28	82.4	31.7	89	192.2	310	590	1094	643	1190	2174
-1.67	29	84.2	32.2	90	194.0	316	600	1112	649	1200	2192
-1.11	30	86.0	32.8	91	195.8	321	610	1130	654	1210	2210
-0.56	31	87.8	33.3	92	197.6	327	620	1148	660	1220	2228
0	32	89.6	33.9	93	199.4	332	630	1166	666	1230	2246
0.56	33	91.4	34.4	94	201.2	366	690	1274	671	1240	2264
1.11	34	93.2	35.0	95	203.0	338	640	1184	677	1250	2282
1.67	35	95.0	35.6	96	204.8	343	650	1202	682	1260	2300
2.22	36	96.8	36.1	97	206.6	349	660	1220	688	1270	2318
2.78	37	98.6	36.7	98	208.4	354	670	1238	693	1280	2336
3.33	38	100.4	37.2	99	210.2	360	680	1256	699	1290	2354
3.89	39	102.2	38	100	212	366	690	1274	704	1300	2372
4.44	40	104.0	43	110	230	371	700	1292	710	1310	2390
5.00	41	105.8	49	120	248	377	710	1310	716	1320	2408
5.56	42	107.6	54	130	266	382	720	1328	721	1330	2426
6.11	43	109.4	60	140	284	388	730	1346	727	1340	2444
6.67	44	111.2	66	150	302	393	740	1364	732	1350	2462
7.22	45	113.0	71	160	320	399	750	1382	738	1360	2480
7.78	46	114.8	77	170	338	404	760	1400	743	1370	2498
8.33	47	116.6	82	180	356	410	770	1418	749	1380	2516
8.89	48	118.4	88	190	374	416	780	1436	754	1390	2534
9.44	49	120.2	93	200	392	421	790	1454	760	1400	2552
10.0	50	122.0	99	210	410	427	800	1472	766	1410	2570
10.6	51	123.8	100	212	413	432	810	1490	771	1420	2588
11.1	52	125.6	104	220	428	348	820	1508	777	1430	2606
11.7	53	127.4	110	230	446	443	830	1526	782	1440	2624
12.2	54	129.2	116	240	464	449	840	1544	788	1450	2642
12.8	55	131.0	121	250	482	454	850	1562	793	1460	2660
13.3	56	132.8	127	260	500	460	860	1580	799	1470	2678
13.9	57	134.6	132	270	518	468	870	1598	804	1480	2696
14.4	58	136.4	138	280	536	471	880	1616	810	1490	2714
15.0	59	138.2	143	290	554	477	890	1634	816	1500	2732
15.6	60	140.0	149	300	572	482	900	1652	821	1510	2750

°C	°F	°C	°F	°C	°F
827	1520	2768	1221	2230	4046
832	1530	2786	1227	2240	4064
838	1540	2804	1232	2250	4082
843	1550	2822	1238	2260	4100
849	1560	2840	1243	2270	4118
860	1580	2876	1249	2280	4138
866	1590	2894	1254	2290	4154
871	1600	2912	1260	2300	4172
877	1610	2930	1266	2310	4190
882	1620	2948	1271	2320	4208
888	1630	2966	1277	2330	4226
893	1640	2984	1282	2340	4244
899	1650	3002	1288	2350	4262
904	1660	3020	1293	2360	4280
910	1670	3038	1299	2370	4298
916	1680	3058	1304	2380	4316
921	1690	3074	1310	2390	4334
927	1700	3092	1316	2400	4352
932	1710	3110	1321	2410	4370
938	1720	3128	1327	2420	4388
943	1730	3146	1332	2430	4406
949	1740	3164	1338	2440	4424
954	1750	3182	1343	2450	4442
960	1760	3200	1349	2460	4460
966	1770	3218	1354	2470	4478
971	1780	3236	1360	2480	4496
977	1790	3254	1366	2490	4514
982	1800	3272	1371	2500	4532
988	1810	3290	1377	2510	4550
993	1820	3308	1382	2520	4568
999	1830	3326	1388	2530	4586
1004	1840	3344	1393	2540	4604
1010	1850	3362	1399	2550	4622
1016	1860	3380	1404	2560	4640
1021	1870	3398	1410	2570	4658
1027	1880	3416	1416	2580	4676
1032	1890	3434	1421	2590	4694
1038	1890	3452	1427	2600	4712
1043	1910	3470	1432	2610	4730
1049	1920	3488	1438	2620	4748
1054	1930	3506	1443	2630	4766
1060	1940	3524	1449	2640	4784
1066	1950	3542	1454	2650	4802
1071	1960	3560	1460	2660	4820
1077	1970	3578	1466	2670	4838
1504	2740	4964	1471	2680	4856
1082	1980	3596	1477	2690	4874
1088	1990	3614	1482	2700	4892
1093	2000	3632	1488	2710	4910
1099	2010	3650	1493	2720	4928
1104	2020	3668	1499	2730	4946
1110	2030	3686	1510	2750	4982
1116	2040	3704	1516	2760	5000
1121	2050	3722	1521	2770	5018
1127	2060	3740	1527	2780	5036
1132	2070	3758	1532	2790	5054
1138	2080	3776	1538	2800	5072
1143	2090	3794	1543	2810	5090
1149	2100	3812	1549	2820	5108
1154	2110	3830	1554	2830	5126
1160	2120	3848	1560	2840	5144
1166	2130	3866	1566	2850	5162
1171	2140	3884	1571	2860	5180
1177	2150	3902	1577	2870	5198
1182	2160	3920	1582	2880	5216
1188	2170	3938	1588	2890	5234
1193	2180	3956	1593	2900	5252
1199	2190	3974	1599	2910	5270
1204	2200	3992	1604	2920	5288
1210	2210	4010	1610	2930	5306
1216	2220	4028	1616	2940	5324

INTERPOLATION TABLE

°C		°F
0.56	1	1.8
1.11	2	3.6
1.67	3	5.4
2.22	4	7.2
2.78	5	9.0
3.33	6	10.8
3.89	7	12.6
4.44	8	14.4
5.00	9	16.2
5.56	10	18.0

°F = 1.8 x °C + 32
 °C = (°F - 32) x 5/9

12

Miscellaneous Conversion Factors

Imperial units			Metric units	
Weights				
1 grain	(=1/7000 lb)	= 0.0648g	1 gram	=15.4 grains
1 dram (dr)		= 1.77 g	1 kilogr (1000 gr)	=2.204 lb
1 ounce (oz)	= 16 dr	= 28.35 g	1 metric ton	= 19.68 cwt
1 pound (lb)	= 16 oz	= 454 g		=2204 lb
1 stone (st)	= 14 lb	= 6.35 kg		= 1000 kg
1 quarter (qr)	= 2 st	= 12.7 kg		
1 central	= 100 lb	= 45.4 kg		
1 hundredweight (cwt)	= 112 lb	= 50.8 kg		
1 quntal		= 100 kg		
1 short ton = 20 centr	= 2000 lb	= 908 kg		
1 long ton = 20 cwt	= 2240 lb			
Linear measures				
1 inch (")		= 25.4 mm	1 mm	= 0.039 inch
1 foot (ft)	= 12 inches	= 30.48 cm	1 cm	= 0.394 inch
1 yard	= 3 ft	= 91.44 cm	1 dm	= 3.937 inches
1 rod, pole or perch	= 5.5 yds	= 5.03 m	1 m	= 39.37 inches
1 chain	= 4 pls	= 20.12 m	1 km	= 0.621 mile
1 furlong	= 10 chs	= 201.2 m		
1 mile	= 8 fri	= 1609 m		
1 sea mile		= 1852 m		
Square measures				
1 sq inch		= 6.45 cm ²	1 cm ²	= 0.155 sq inch
1 sq foot	= 144 sq inches	= 9.29 dm ²	1 dm ²	= 15.5 sq inches
1 sq yard	= 9 sq ft	= 0.836 m ²	1 m ²	= 1.196 sq yard
1 sq pole	= 30.2509 sq yd	= 25.29 m ²	1 are	= 119.6 sq yard
1 rood	= 40 sq pls	= 10.1 are	1 hectare	= 2.471 acres
1 acre	= 4 roods	= 0.4047 ha	1 km ²	= 247 acres
1 sq mile	= 640 acres	= 259 ha		

Imperial units	Metric units
Cubic measures	
1 cu inch = 16.39 cm ³ 1 cu foot = 1728 cu inch = 28.32 dm ³ 1 cu yard = 27 cu ft = 0.765 m ³ 1 gill = 8.655 cu inches = 142 cm ³ 1 pint = 4 gills = 0.568 dm ³ 1 quart = 2 pints = 1.136 dm ³ 1 gallon = 4 quarts = 4.546 dm ³ 1 peck = 2 gallons = 9.092 dm ³ 1 bushel = 4 pecks = 36.37 dm ³ 1 quarter = 8 bushels = 2.909 hl 1 barrel = 31.5 gallons = 1.432 hl 1 hogshead = 2 barrels = 2.864 hl	1 cm ³ = 0.061 cu inch 1 dm ³ = 61.02 cu inches 1 m ³ = 1.308 cu yds 1 centliter = 0.07 gill 1 deciliter = 0.176 pint 1 liter = 1.759 pint 1 hectoliter = 22 gallons or = 2.75 bushels
Density	
1 lb/cu inch = 27.7 g/cm ³ 1 lb/cu ft = 16.0 kg/m ³	1 g/cm ³ = 0.0361 lb/cu inch 1 kg/m ³ = 0.0624 lb/cu ft
Force	
1 lbf (pound-force) = 4.45 N	1 N = 0.225 lbf
Pressure	
1 lbf/sq inch = 6.89 · 10 ³ N/m ² 1 ton/sq inch = 15.444 N/mm ²	1 N/m ³ = 0.145 · 10 ⁻³ lbf/sq inch 1 N/mm ² = 145.04 lbf/sq inch 1 N/mm ² = 0.0647 49 ton-force/sq inch 1 Pa = 1 N/m ²
Energy	
1 Btu (British thermal unit) = 1055 J = 0.293 · 10 ⁻³ kWh = 1055 Nm	1 J = 0.948 · 10 ⁻³ Btu 1 kWh = 3412 Btu 1 Nm = 0.948 · 10 ⁻³ Btu 1 kcal = 3.97 Btu
Thermal conductivity	
1 Btu/ft h °F = 1.73 W/mK 1 Btu inch/ft ² h °F = 0.143 W/m ² K	1 W/mK = 0.578 Btu/ft h °F = 6.93 Btu inch/ft ² h °F

12 Thermocouples

Thermocouples	Maximum service		Atmosphere temperature °C	Reference Junction compensation
	Continuous	Intermittent		
Type S Pt-10Rh v Pt	1400	1650	Oxidising Neutral Vacuum	Compensating leads, see B.S. 1843
Type R Pt-13Rh v Pt	1400	1650	Oxidising Neutral Vacuum Reducing	Compensating leads, see B.S. 1843
Type B Pt-30Rh v Pt-6Rh	1500	1800	Oxidising Neutral Vacuum	Not normally necessary
Pt-40Rh v Pt-20Rh	1600	1800	Oxidising Neutral Vacuum	Not normally necessary
Ir-40Rh v Ir	2000	2100	Neutral Vacuum Oxidising	Copper v Aluminium
W v W-26Re	2300	2600	Neutral Vacuum Reducing	Use reference junction correction table



Fig. 75 Intensity of black body radiation.

Fig. 76 Car bottom furnace for forging and annealing.

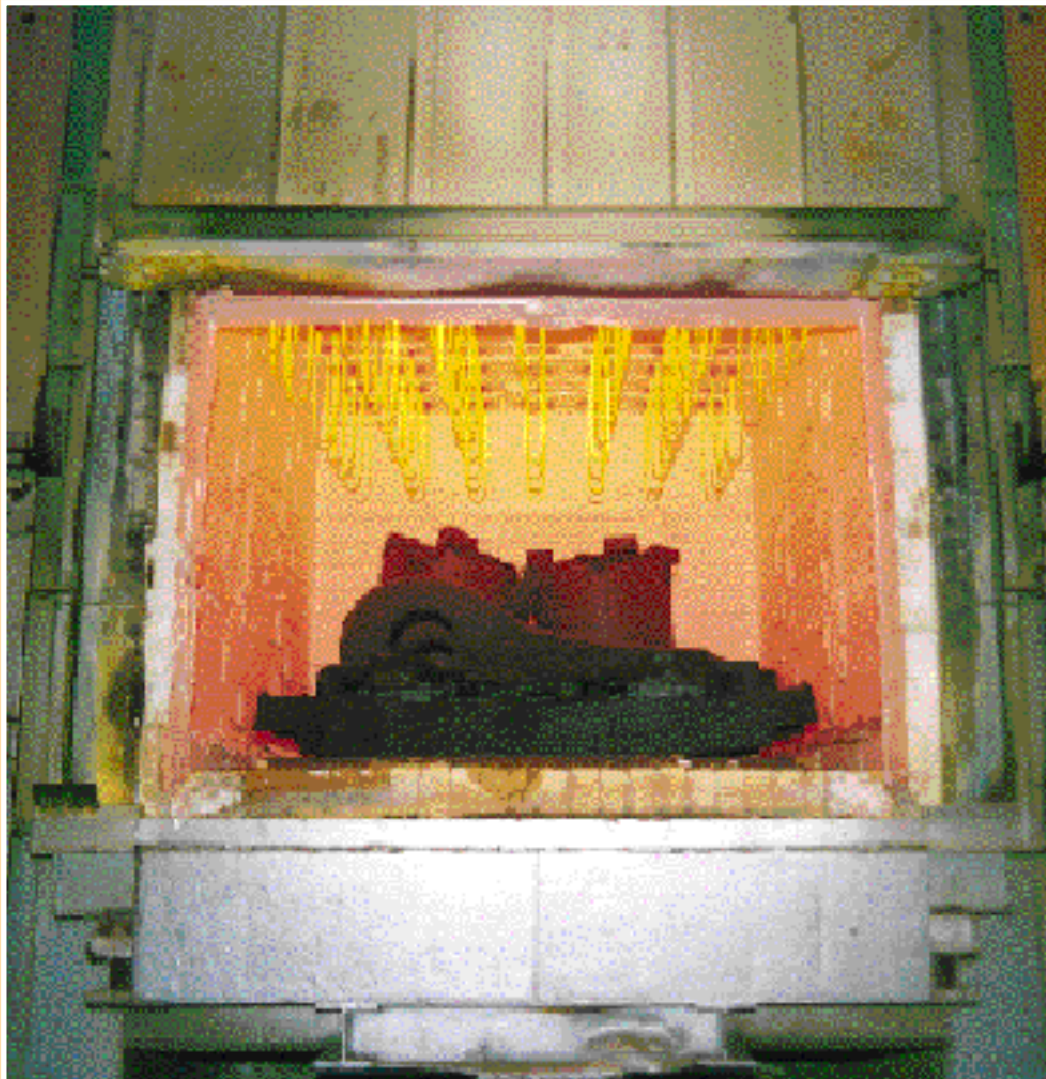

Heat transfer by radiation

For radiation from an ideal black solid the following so called thesis of Stefan-Boltzmann holds:

$$Q_s = C_s \times \left(\frac{T}{100}\right)^4 \text{ W/m}^2 \quad C_s = \text{Coefficient of radiation for a black body} = 5.67 \text{ W/m}^2 \text{ K}^4.$$

For radiation from one solid to another solid with equal surfaces, through a transparent non-absorbing medium, the following holds:

$$Q_s = C_r \times A \times \left[\left(\frac{T_1}{100}\right)^4 - \left(\frac{T_2}{100}\right)^4 \right]$$

$$C_r = \frac{1}{\frac{1}{C_1} + \frac{1}{C_2} - \frac{1}{5.67}} \quad \begin{array}{l} C_1 \text{ and } C_2 = \text{Coefficient of radiation for the two surfaces} \\ T_1 = \text{Surface temperature of the radiating body in } ^\circ\text{K} \\ T_2 = \text{Surface temperature of the work piece in } ^\circ\text{K} \end{array}$$

The coefficient of radiation for the two surfaces are:

$$C_1 = \epsilon_1 \times C_s \quad C_2 = \epsilon_2 \times C_s \quad \epsilon_1 \text{ and } \epsilon_2 \text{ from table below}$$

If the area A_2 is surrounding the area A_1 completely:

$$C_r = \frac{1}{\frac{1}{C_1} + \frac{A_1}{A_2} \left(\frac{1}{C_2} - \frac{1}{5.67}\right)}$$

In furnace practice, the surface of the furnace interior is usually four or more times the projected area of the charge. The surface of the KANTHAL SUPER elements is about 10% of the surface of the furnace interior. Considering the heating equation above, this means that only about 20% of the power is transferred directly from the heating elements to the charge. The remaining 80% is transferred indirectly by the furnace interior.

Emissivity ϵ , guiding values

Material		Temp °C	Temp °F	ϵ
Aluminium	bright	500	930	0.06
	oxidized	600	1110	0.18
Brass	bright	100	210	0.04
	oxidized	600	1110	0.60
Copper	bright	100	210	0.02
	oxidized	1000	1830	0.60
Iron	bright	100	210	0.30
	oxidized	1200	2190	0.85
Nickel	bright	1000	1830	0.20
	oxidized	1200	2190	0.85
Platinum	bright	1500	2730	0.20
Steel	bright	100	210	0.10
	oxidized	600	1110	0.80
Firebrick		1000	1830	0.80
Zirconia		1400	2550	0.40
KANTHAL SUPER		1400	2550	0.70
Aluminium paint				0.55
Sooted surface				0.97
Black body				1.00

Table 11.

12

Calculation of furnace insulation

Flat furnace wall

The heat flow Q Watts through a flat furnace wall with the area A m² and with one or more layers of insulation can be calculated according to the formula:

$$Q = k A (T_f - T_a) W$$

- k = Thermal conductivity, W/(m² °C)
- T_f = Furnace temperature, °C
- T_a = Temperature of the ambient air, °C
- α = Coefficient of heat transfer, W/(m² °C)
- s = Thickness of layer, m
- λ = Thermal conductivity, W/(m °C)

In high temperature furnaces $\alpha_1 = 100$ W/(m² °C)
 Non-metallic surfaces, e. g. cement $\alpha_2 = 10.0$ W/(m² °C)
 and metal surfaces that have been painted.
 Galvanized or planished steel; finishes in $\alpha_2 = 8.0$ W/(m² °C)
 the nature of metallic paints.
 Bright metallic surfaces, e. g. polished aluminium. $\alpha_2 = 5.7$ W/(m² °C)

$$k = \frac{1}{\frac{1}{\alpha_1} + \frac{s_1}{\lambda_1} + \frac{s_2}{\lambda_2} + \frac{s_3}{\lambda_3} + \frac{1}{\alpha_2}} \text{ (for three layers)}$$

The temperatures between the different layers of insulation are calculated as follows:

$$T_b = T_f - \frac{1}{\alpha_1} \times k (T_f - T_a)$$

$$T_1 = T_b - \frac{s_1}{\lambda_1} \times k (T_f - T_a)$$

$$T_2 = T_1 - \frac{s_2}{\lambda_2} \times k (T_f - T_a) \quad T_b = \text{Hot face temperature, } ^\circ\text{C}$$

$$T_s = T_2 - \frac{s_3}{\lambda_3} \times k (T_f - T_a) \quad T_s = \text{Cold face temperature, } ^\circ\text{C}$$

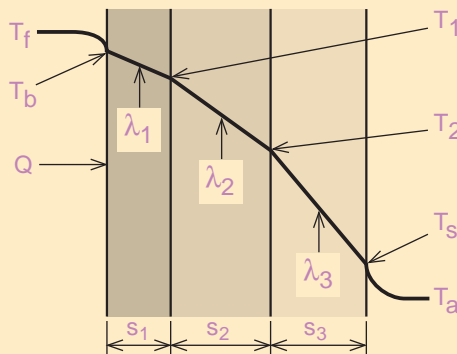

Tubular furnace wall

The heat flow Q Watts through a tubular furnace wall with the length L m and with one or more layers of insulation can be calculated according to the formula:

$$Q = k_r L (T_f - T_a) W$$

$$k_r = \frac{\pi}{\frac{1}{\alpha_1 d_1} + \frac{0.5}{\lambda_1} \ln\left(\frac{d_2}{d_1}\right) + \frac{0.5}{\lambda_2} \ln\left(\frac{d_3}{d_2}\right) + \frac{0.5}{\lambda_3} \ln\left(\frac{d_4}{d_3}\right) + \frac{1}{\alpha_2 d_4}} \quad \text{(for three layers)}$$

k_r = Thermal conductivity, W/(m°C).

\ln = natural logarithm.

d = diameter, m.

The temperatures between the different layers of insulation are calculated as follows:

$$T_b = T_f - \frac{1}{\pi \alpha_1 d_1} \times k_r (T_f - T_a)$$

$$T_1 = T_b - \frac{0.5}{\pi \lambda_1} \times k_r (T_f - T_a) \times \ln\left(\frac{d_2}{d_1}\right)$$

$$T_2 = T_1 - \frac{0.5}{\pi \lambda_2} \times k_r (T_f - T_a) \times \ln\left(\frac{d_3}{d_2}\right)$$

$$T_s = T_2 - \frac{0.5}{\pi \lambda_3} \times k_r (T_f - T_a) \times \ln\left(\frac{d_4}{d_3}\right)$$

