

## Operation Manual/FGX-OM-K003 Clean Air Filter SFD Series

Be sure to read this manual carefully before using the product.

For additional information such as construction and detailed specifications refer to the drawing, catalog and/or other related literature for the product.

This manual is subject to change without prior notice.

### Selection

1. Thoroughly and carefully check the purpose of use, required specifications and operating conditions then select a model with the appropriate specifications.
2. Contact SMC beforehand when the product will be used in applications such as a caisson shield and for breathing and/or medical treatment that affects the human body either directly or indirectly.

### Mounting

#### Warning

1. Operation Manual  
Read and understand this Operation Manual carefully before mounting and using the product and keep it available for future reference.
2. Flushing  
Flush and clean the piping before connecting it to the product. If the piping has dust or other contaminants the product may fail or break. Also, ensure that all required mounting parts are firmly fixed before using the product.
3. Use tube fittings with resin threads for the piping to the IN and OUT ports. If a fitting with metal threads is used it may damage the ports. (Only for SFD100)
4. Follow directions for the one-touch fitting to connect tubing to the one-touch fitting at the IN and OUT ports.
5. Check the flow direction for the tubing indicated by an arrow. Connecting the tubing incorrectly may damage the element.

### Installation

#### Warning

1. The element may lose its given performance if the pressure difference (pressure drop) between the primary pressure and secondary pressure exceeds 0.1MPa.
2. Design your system to allow this product to be mounted in a place without vibrations, which can cause the pressure difference to exceed 0.1MPa.
3. Beware of dust from air equipment mounted at the secondary side. If such equipment is mounted there it may generate dust and decrease the cleanliness of the product. Check the mounting position of the air equipment.
4. Set the air-flow capacity with an initial pressure drop of 0.03MPa or less. If the initial pressure drop exceeds the required value the flow over the rated value will clog the element, which may shorten the product's life span.
5. Determine the appropriate model by assessing the maximum consumption flow rate. When using compressed air for an air blow application, calculate the maximum volume of air that will be consumed before selecting the SFD series product size.
6. Generally compressed air could contain the following particle contaminants:
  - Moisture (drain)
  - Dust sucked from ambient air
  - Deteriorated oil discharged from compressor
  - Solid foreign matter such as rust and oil in the piping
  - 1) The SFD series is not available for compressed air containing a liquid such as water and oil.
  - 2) Install a dryer, mist separator, micro mist separator, super mist separator, odor removal filter, etc. for the air source used for the SFD series.

### Piping

#### Warning

1. The filter was packed in anti-static closing double packaging in a clean room and the inner package should be removed in a clean environment (clean room, etc.).
2. For the piping, apply a wrench to two chamfered flats or width-across flats on the IN or OUT side to prevent the product housing from rotating.
3. Use the following torque specifications to screw fittings into the product.

Thread size	Material	torque(N·m)
Rc1/4	Resin	2 to 3
	Metal	12 to 14

4. Flush (air blow) the product when the filter is used for the first time or has been replaced. When connecting piping and other fittings flush before first use or when replacing parts to reduce the effect of dust and other contaminants. Also flush the line to eliminate contaminants that may result from installing the pipe line. Be sure to flush the line before actually running the system.

### Maintenance

#### Warning

1. Follow the procedure described in this manual to replace the element. When the element is replaced incorrectly it may cause damage and failure to equipment and the machine.
2. Exhaust the air supply completely to release all pressure in the product.
3. When the element comes to the end of its life immediately replace it with a new filter or replacement element (cartridge type).
  - When to replace the element-
    - After one year of operation.
    - The pressure drop has reached 0.1MPa even before a year elapses.
4. Do not disconnect and replace the one-touch fitting.

### Environment

#### Warning

1. Do not use the product in the following environments, which could cause failure.
  - In or near a place that may be exposed to a corrosive gas, organic solvent or chemicals.
  - A place exposed to water, steam or oil. Direct sunlight (ultraviolet) and high temperatures that may deteriorate resin.
  - A place with a heat source and poor ventilation. (Shade the heat source with heating insulation.)
  - A place exposed to impact and vibration.
  - A place exposed to excessive humidity and dust.
2. When air blowing, be careful not to contaminate a work piece with entrained ambient air. If air blowing with compressed air the air emitted from a blow nozzle may entrain foreign matter (solid and/or liquid) from the ambient air and attach it to the work piece. Check the ambient environment.

### 1. Description and Function of Each Part

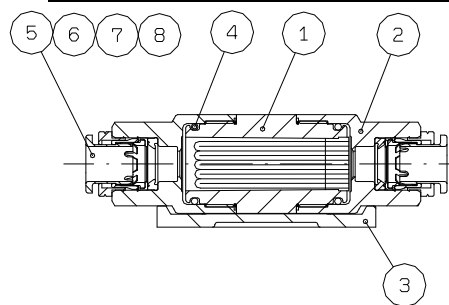

Symbol	Description	Material	Function
①	Element	Case: Clear resin	Traps foreign matters.
②	Cover	Resin	Holds the element and cover.
③	Bracket	Resin	Fixes the housing.
④	O-ring	Rubber	Seals the element, cover and fitting body.
⑤	Seal	Rubber	
⑥	Cushion	Rubber	Seals the tube at IN and OUT side, disconnects/connects and holds the tube.
⑦	Stopper	SUS	
⑧	Cassette	SUS	

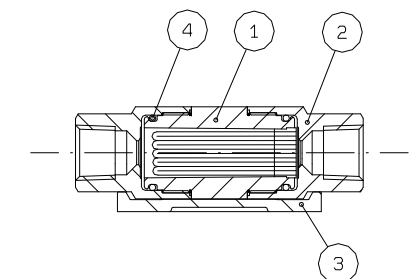

Symbol	Description	Material	Function
①	Element	Case: Clear resin	Traps foreign matters.
②	Cover	Resin	Thread piping at IN and OUT side.
③	Bracket	Resin	Fixes the housing.
④	O-ring	Rubber	Seals the element, cover and fitting body.

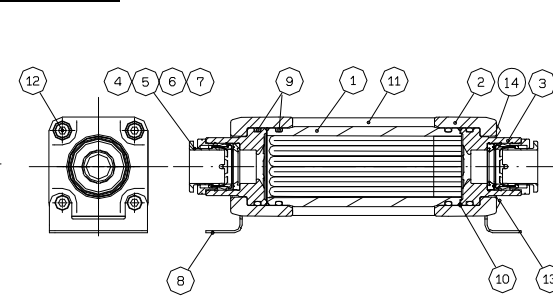

Symbol	Description	Material	Function
①	Element	Case: Clear resin	Traps foreign matters. *Replace when clogged.
②	Cover	Aluminum	Holds the element and cover.
③	Fitting body	Resin	
④	Seal	Rubber	
⑤	Cushion	Rubber	Seals the tube at IN and OUT side, disconnects/connects and holds the tube.
⑥	Stopper	SUS	
⑦	Cassette	SUS	
⑧	Bracket	SUS	Fixes the housing.
⑨	O-ring A	Rubber	Seals the element, cover and fitting body.
⑩	O-ring B	Rubber	Seals the element, cover and fitting body.
⑪	Rod cover	SUS	Locates the position of covers.
⑫	Tie rod	SUS	
⑬	Cap nut	Steel	Joins each part.
⑭	Plain washer	Steel	

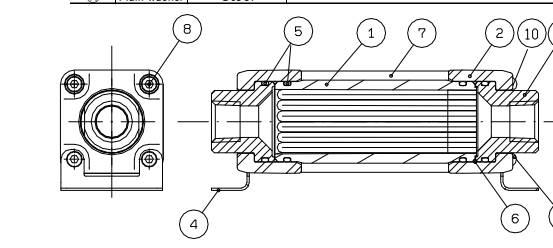

Symbol	Description	Material	Function
①	Element	Case: Clear resin	Traps foreign matters. *Replace when clogged.
②	Cover	Aluminum	Holds the element and cover.
③	Fitting body	SUS	Thread piping at IN and OUT side.
④	Bracket	SUS	Fixes the housing.
⑤	O-ring A	Rubber	Seals the element, cover and fitting body.
⑥	O-ring B	Rubber	
⑦	Rod cover	SUS	Locates the position of covers.
⑧	Tie rod	SUS	
⑨	Cap nut	Steel	Joins each part.
⑩	Plain washer	Steel	

### 2. Specifications

	SFD100	SFD200
Port size	One-touch fitting φ4, 6, 8	One-touch fitting φ8, 10, 12
	Rc1/4, NPT1/4, G1/4	Rc1/4, NPT1/4, G1/4
Fluid	Air, (Nitrogen)	Air, (Nitrogen)
Air flow capacity <sup>Note 1)</sup>	100L/min(ANR)	500L/min(ANR)
Filtration rating	0.01μm (99.99%)	
MAX Operating pressure	1.0MPa (0.99MPa for Nitrogen) at 20°C	
Operating temp.	5 to 45°C	
Initial pressure loss	0.03MPa or less (at primary pressure of 0.7MPa and max. air flow capacity)	
Element proof differential pressure <sup>Note 2)</sup>	0.5MPa	
Proof pressure	1.5MPa	
Assembly environment	Clean room (class 100)	

Note 1) The air flow capacity is the flow rate at a primary pressure of 0.7MPa. Also, it will change depending on the port size and operating pressure.

Note 2) This means that the element will not break at 0.5MPa.

### 3. How to mount

- Check which side is IN and OUT before connecting. The direction of IN and OUT must follow the arrow marking on the product housing.

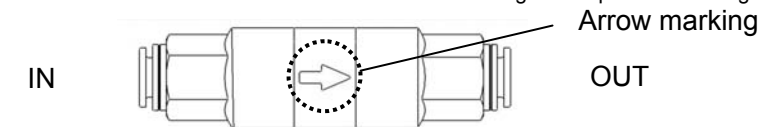

\*The figure shows SFD100-C08.

- Ensure that each sealing part does not leak.
- Keep a space on the cover (at the IN side) to remove the element for maintenance.
- Follow the instructions for the one-touch fitting to connect and disconnect tubing.

### 4. How to replace the element

The SFD200 element can be replaced. Follow the procedure shown below to replace it. The SFD100 element cannot be disassembled or replaced. It is therefore necessary to replace the entire housing to replace the element.

«Reference for the replacement of element»

Refer to the following pressure loss value to replace the element.

Referential pressure loss for the replacement of element: 0.1MPa (initial pressure loss: 0.03MPa)

«How to replace the element»

- 1) Stop the operation
  - Stop the operation of the product and release the internal pressure.
- 2) Remove the cover
  - Remove the nut and pull out the tie rod.
  - Pull out the cover (1) from the element and remove the rod cover.
- 3) Mount the element
  - Mount a new element on the cover and return the rod cover.
- 4) Mount the rod cover
  - Line up the flange on the rod cover with the matching socket on the cover, bottom out the rod cover, insert the tie rod, replace the nuts and tighten.
  - Ensure that the cover cannot be pulled out.
  - Mount the plain washer to the tie rod which the bracket does not pass.
- 5) Start the operation
  - Follow the procedure described in "3. How to mount" to start the operation.

«Element for replacement»

Applicable size	Part number	Including
SFD200	SFD-EL200	Element + O-ring (3 pcs)